



Yaris

Toyota Parking Aid 400

Installation instructions

Model year:	2008
Vehicle code:	**P90X*-****KW
Part number:	PZ464-B0423-00
Sensor kit:	PZ464-00422-**
Switch (Optional):	PZ464-T3420-55
Connetors (T-Sport only):	90980-10796, 82824-52050
 Weight:	Main Kit 1 0.7 kg Sensor Kit 0.1 kg

Manual reference number: AIM 001 218-2

Revision Record

Rev. No.	Date	Page	Picture	Update	New	Deleted Steps
1	12.01.09	6	Kit	X		
1	12.01.09	7	1	X		
1	12.01.09	18				X
1	12.01.09	19				X
2	11.05.09	11		X		
2	11.05.09	18				X
2	11.05.09	21				X
2	11.05.09	21			X	
2	11.05.09	22			X	

GB

- Expert Fitment Required.
- Disconnect the battery earth cable.
- To avoid damage to the wiring harness, ensure contact with sharp edges is prevented.
- Install parts as shown on illustrations.
- Re-connect battery.
- Re-fit panels, ensure that the wiring harness and other components are neatly and securely located.

D

- Montage durch Fachwerkstatt erforderlich.
- Massekabel von Batterie abklemmen.
- Zur Vermeidung von Beschädigungen an der Kabelisolation ist Berührung mit scharfen Kanten zu vermeiden.
- Teile gemäß Abbildung montieren.
- Batterie wieder anschließen.
- Paneele wieder anbringen; achten Sie darauf, daß der Kabelbaum und andere Teile ordnungsgemäß und genau positioniert sind.

E

- Montaje sólo por el concesionario.
- Desconectar el cable de masa de la batería.
- A efectos de evitar desperfectos en el aislamiento del cable, hay que evitar el contacto con aristas cortantes.
- Montar las piezas tal como se indica en las figuras.
- Vuelva a conectar la batería.
- Volver a colocar los paneles; preste atención a que el mazo del cable y las demás piezas tengan la posición correcta y precisa.

F

- Montage par spécialiste nécessaire.
- Débrancher le câble de masse de la batterie.
- Eviter tout contact avec des arêtes vives afin de ne pas endommager l'isolation des câbles.
- Monter les pièces selon les figures.
- Reconnecter la batterie.
- Remettre le panneau; veillez à ce que le faisceau et les autres pièces soient positionnés correctement et avec la précision requise.

I

- E' necessario in officina specializzata.
- Staccare il cavo di massa dalla batteria
- Allo scopo di evitare danni all'isolazione dei cavi, evitare di metterli a contatto con spigoli acuti.
- Montare le parti secondo quanto rilevabile delle illustrazioni.
- Riconnettere la batteria.
- Rimettere in posizione i pannelli; far ben attenzione che il fascio di cavi e le altre parti siano state posizionate con esattezza e nella dovuta maniera.

P

- Especialista em montagem requerido.
- Separe o cabo de terra do acumulador.
- Para não se danificar a isolação dos cabos, é conveniente evitar-se contacto com arestas afiadas.
- Monte as partes conforme ilustrado.
- Recolocar a bateria
- Tornar a colocar os painéis; verificar se a árvore de cabos e outras peças estão na posição exacta e prescrita.

NL

- Montage door vakman nodig.
- Massakabel van accu losmaken.
- Ter vermindering van beschadiging aan de isolatie van de elektrokit dient contact met scherpe kanten te worden vermeden.
- Delen overeenkomstig afbeelding monteren.
- Accu weer aansluiten.
- Panelen weer monteren; let erop, dat de kabelboom en andere delen correct en netjes gepositioneerd worden.

DK

- Montage ved professionelt værksted påkrævet.
- Stelkabel fjernes fra batteri.
- Berøring med skarpe kanter skal undgås for at undgå beskadigelse af kabelisoleringen.
- Dele skal monteres i henhold til illustrationer.
- Tilslut batteri igen.
- Paneler fastgøres igen; vær opmærksom på, at kabelsamlingen og andre dele placeres korrekt og præcist.

NO

- Nødvendig med montering fra fagvegverksted.
- Klem jordkabelen av batteriet.
- For å unngå skader på kabelisoleringen må berøring av skarpe kanter unngås.
- Monter alle deler i henhold til illustrasjonene.
- Tilkoppl batteriet igjen.
- Monter panelene igjen, og pass på at kabelbunten og andre deler er anbrakt ordentlig og på riktig sted.

SV

- Verkstadsmontage erfordras.
- Lossa stombakeln från batteriet.
- För att förhindra skador på ledningarnas isolation skall berøring med vassa kanter undvikas.
- Montera detaljerna enligt figurerna
- Anslut batteriet igen.
- Sätt tillbaka panelerna igen; kontrollera noga att ledningsmattan och andra detaljer ligger på rätt plats.

FI

- Asennus tarpeen merkkikorjaamossa.
- Erotta maadoitusjohto akusta
- Pidä huoli myös siitä, että kaapelointi on korin kiinnityksen myötäinen ja kiinnitetty huolellisesti muihin liikkuviin osiin.
- Asenna osat kuvien mukaan.
- Kytke akku takaisin.
- Aseta paneelit paikalleen; tarkista, että kaapelointi ja muut osat ovat asianmukaisesti ja tarkalleen paikoillaan.

CS

- Montáž ve specializované dílně nutná.
- Odpojte zemnicí kabel od baterie.
- Zabraňte tomu, aby se kabely poškodily tím, že jsou položeny na ostrých hranách.
- Montujte části podle vyobrazení
- Opět připojit baterii.
- Opět připevněte panely; dbejte na to, aby svazek kabelů a ostatní části byly uloženy na správném místě.

HU

- A szereléshez szakműhely kell.
- Húzza le az akkumulátor testkábeljét.
- A kábelszigetelés megsérülésének elkerülésére ügyeljen arra, hogy a kábel ne juthasson érintkezésbe éles peremű alkatrészekkel.
- Az alkatrészeket az ábrák szerint szerelje be.
- Ismét csatlakoztassa az akkumulátort.
- Szerelje vissza a fedőlapokat, ügyeljen arra, hogy a kábelek és a többi alkatrész pontosan a számukra kijelölt helyen maradjanak.

PL

- Konieczny montaż przez warsztat specjalistyczny.
- Odłączyć przewód masy od akumulatora.
- Dla zapobieżenia uszkodzeniu izolacji chronić przed zetknięciem z ostrymi krawędziami.
- Zamontować części zgodnie z rysunkiem.
- Ponownie podłączyć akumulator.
- Na powrót osadzić osłony; zadbać aby wiązka kablowa i inne części były właściwie i dokładnie ułożone.

EL

- Να τοποθετεί από συνεργείο.
- Αποσυνδέστε το καλώδιο γείωσης από τη μπαταρία.
- Για να αποφευχθούν ζημιές στη μόνωση καλωδίων, να αποφεύγεται η επαφή των με αιχμηρές ακμές.
- Τοποθέτηση των μερών σύμφωνα με τις Εικόνες.
- Συνδέστε πάλι τη μπαταρία.
- Τοποθετήστε πάλι το κάλυμμα· προσοχή, η πλεξούδα καλωδίων και άλλα μέρη να είναι τοποθετημένα ακριβώς και σύμφωνα με τους κανονισμούς.

RU











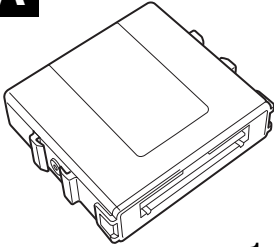
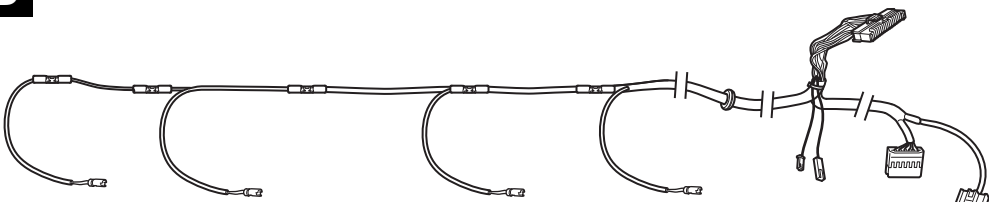
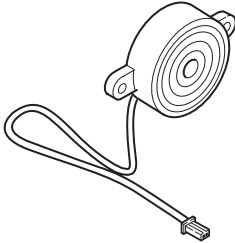
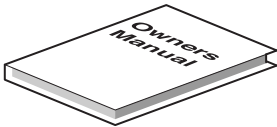
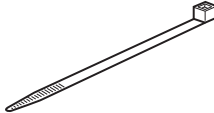
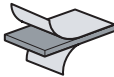
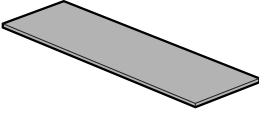
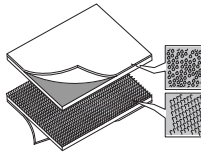
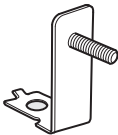

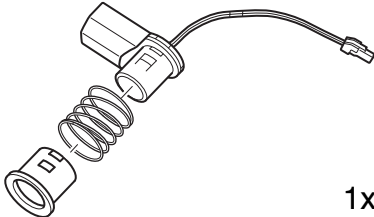
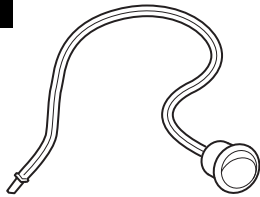
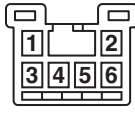
- Монтаж должны выполнять специалисты в мастерской
- Отсоединить заземляющий кабель аккумулятора
- Во избежание повреждений изоляции кабеля не допускать соприкосания с острыми углами
- Монтировать части согласно иллюстрации
- Снова подключить аккумулятор
- Установить панель, проверить правильность и точность расположения кабелей и других частей

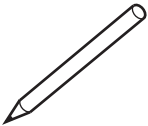
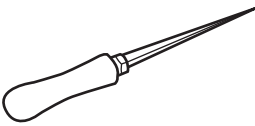
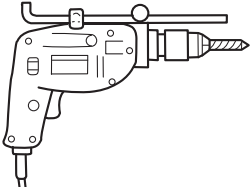
TR

- Uzmanın takması gereklidir .
- Akü toprak kablosunu ayırın.
- Kablo demetinin hasar görmemesi için, sivri objelerle temasını engellenmesini sağlayın.
- Parçaları çizimlerde gösterildiği gibi takın.
- Aküyü tekrar bağlayın.
- Panoları tekrar takın, kablo demeti ve diğer komponentlerin tam ve sıkıca yerleşmesini sağlayın.

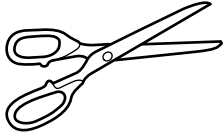
	EN	DE	ES	FR	IT	PT	NL	DA	NO
L	Blue	Blau	Azul	Bleu	Blu	Azul	Blauw	Blå	Blå
B	Black	Schwarz	Negro	Noir	Nero	Preto	Zwart	Sort	Sort
BR	Brown	Braun	Marrón	Marron	Marrone	Castanho	Bruin	Brun	Brun
DL	Dark blue	Dunkelblau	Azul oscuro	Bleu foncé	Blu scuro	Azul-escuro	Donkerblauw	Mørkeblå	Mørkeblå
DG	Dark green	Dunkelgrün	Verde oscuro	Vert foncé	Verde scuro	Verde-escuro	Donkergroen	Mørkegrøn	Mørkegrønn
G	Green	Grün	Verde	Vert	Verde	Verde	Groen	Grøn	Grønn
GR	Grey	Grau	Gris	Gris	Grigio	Cinzeno	Grijs	Grå	Grå
LB	Light blue	Hellblau	Azul claro	Bleu clair	Blu chiaro	Azul-claro	Lichtblauw	Lyseblå	Lyseblå
LG	Light green	Hellgrün	Verde claro	Vert clair	Verde chiaro	Verde-claro	Lichtgroen	Lysegrøn	Lysegrønn
NO	Natural colour	Naturfarben	Color natural	Nature	Colori naturali	Cores naturais	Naturel	Naturfarvet	Naturfarger
O	Orange	Orange	Naranja	Orange	Arancione	Laranja	Oranje	Orange	Orange
P	Pink	Rosa	Rosa	Rose	Rosa	Rosa	Rosé	Rosa	Rosa
R	Red	Rot	Rojo	Rouge	Rosso	Vermelho	Rood	Rød	Rød
PU	Purple	Purpur	Púrpura	Pourpre	Rosso porpora	Púrpura	Paars	Purpur	Purpur
SB	Sky blue	Himmelblau	Azul cielo	Bleu ciel	Celeste	Azul-céu	Hemelsblauw	Himmelblå	Himmelblå
T	Yellow brown	Gelbbraun	Amarillo-marrón	Marron-jaune	Giallomarrone	C a s t a n h o - amarelado	Geelbruin	Gulbrun	Gulbrun
W	White	Weiß	Blanco	Blanc	Bianco	Branco	Wit	Hvid	Hvit
Y	Yellow	Gelb	Amarillo	Jaune	Giallo	Amarelo	Geel	Gul	Gul
V	Violet	Violett	Violeta	Violet	Viola	Violeta	Violet	Violet	Fiolett

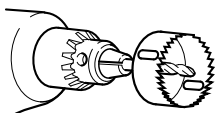
	SV	FI	CS	HU	PL	EL	RU	TR
L	Blå	Sininen	Modrá	Kék	Niebieska	Μπλε	Синий	Mavi
B	Svart	Musta	Černá	Fekete	Czarna	Μαύρο	Чёрный	Siyah
BR	Brun	Ruskea	Hnědá	Barna	Brazowa	Καφέ	Коричневый	Kahverengi
DL	Mörkblå	Tummansininen	Tmavomodrá	Sötétkék	Granatowa	Σκούρο μπλε	Тёмно-синий	Koyu mavi
DG	Mörkgrön	Tummanvihreä	Tmavozelená	Sötétzöld	Ciemnozielona	Σκούρο πράσινο	Тёмно-зелёный	Koyu yesil
G	Grön	Vihreä	Zelená	Zöld	Zielona	Πράσινο	Зелёный	Yeşil
GR	Grå	Harmaa	Šedá	Szürke	Szara	Γκρι	Серый	Gri
LB	Ljusblå	Vaaleansininen	Bleděmodrá	Világoskék	Jasnoniebieska	Ανοικτό μπλε	Голубой	Acik mavi
LG	Ljusgrön	Vaaleanvihreä	Světlezelená	Világoszöld	Jasnozielona	Ανοικτό πράσινο	Светло-зелёный	Acik yesil
NO	Naturfarger	Luonnonväri	Přírodní barva	Természetes színű	Barwy naturalne	Φυσικά χρώματα	Телесный	Naturel
O	Orange	Oranssi	Oranžová	Narancs	Pomarańczowa	Πορτοκαλί	Оранжевый	Turuncu
P	Rosa	Rosa	Růžová	Rózsaszín	Różowa	Ροζ	Розовый	Pembe
R	Röd	Punainen	Červená	Piros	Czerwona	Κόκκινο	Красный	Kırmızı
PU	Purpur	Purppura	Purpurová	Bíborvörös	Purpurowa	Πορφυρό	Пурпурный	Mor
SB	Himmelsblå	Taivaansininen	Blankytá	Égyszínkék	Bękitna	Γαλάζιο	Небесно-голубой	Gök mavisi
T	Gulbrun	Keltaisenruskea	Žlutohnědá	Sárgásbarna	Żółto-brązowa	Κιτρινοκαφέ	Жёлто-коричневый	Sarıkahverengi
W	Vit	Valkoinen	Bílá	Fehér	Biała	Λευκό	Белый	Beyaz
Y	Gul	Keltainen	Žlutá	Sárga	Żółta	Κίτρινο	Жёлтый	Sarı
V	Violett	Violett	Fialová	Ibolyakék	Fioletowa	Μοβν	Фиолетовый	Menekşe

<p>A</p>  <p>1x</p>	<p>B</p>  <p>1x</p>			
<p>C</p>  <p>1x</p>	<p>D</p>  <p>1x</p>	<p>E</p>  <p>3x</p>	<p>F</p>  <p>1x</p>	
<p>G FOAM</p>  <p>1x</p>	<p>H</p>  <p>1x</p>	<p>I</p>  <p>1x</p>	<p>J</p>  <p>1x</p>	<p>K</p>  <p>1x</p>
<p>PZ464-00422-**</p>		<p>PZ464-T3420-55</p>		<p>T-sport only</p>
<p>L</p>  <p>1x</p>	<p>M</p>  <p>1x</p>	<p>N</p> <p>90980-10796</p>  <p>1x</p>	<p>O</p> <p>82824-52050</p>  <p>1x</p>	
				
 <p>Ø 2 mm Ø 10 mm</p>			 <p>CLEAN</p>	
 <p>Ø 20 mm</p>				

STANDARD

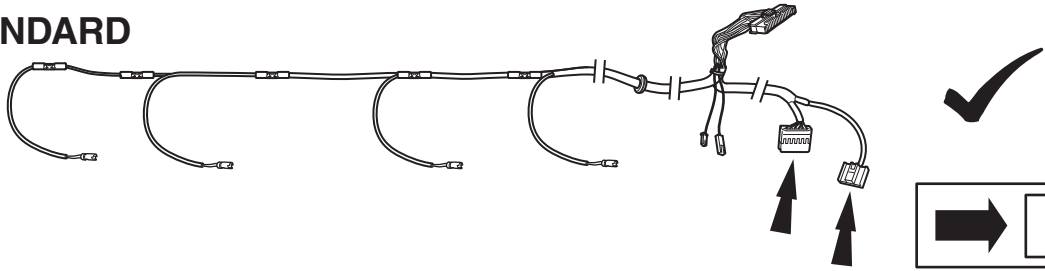

T-sport

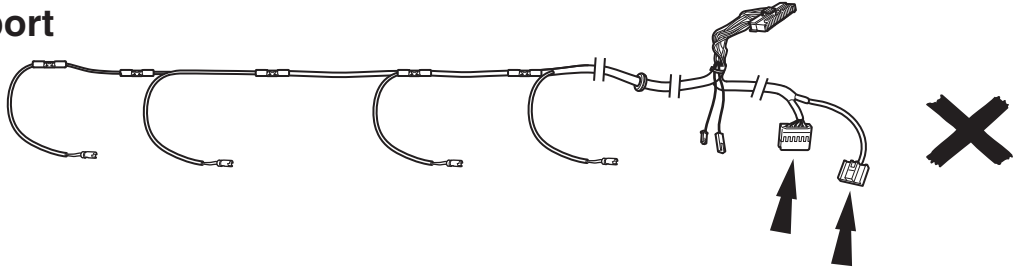

T-sport

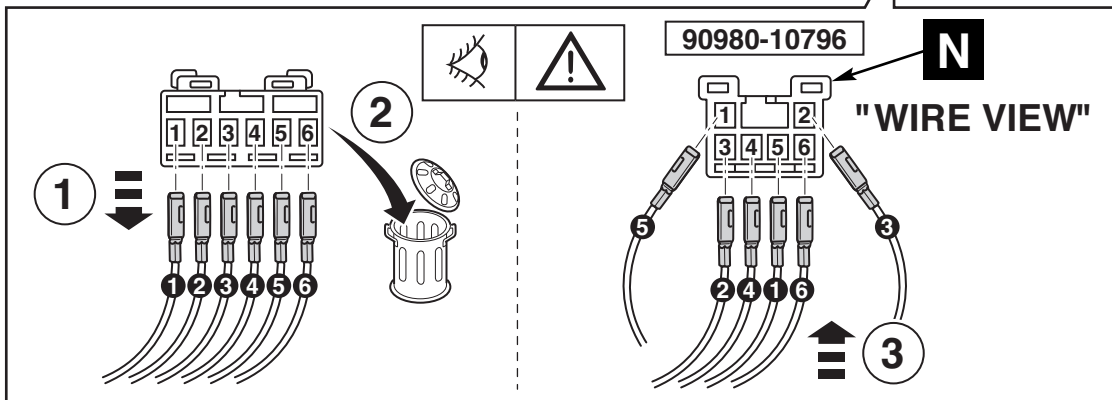
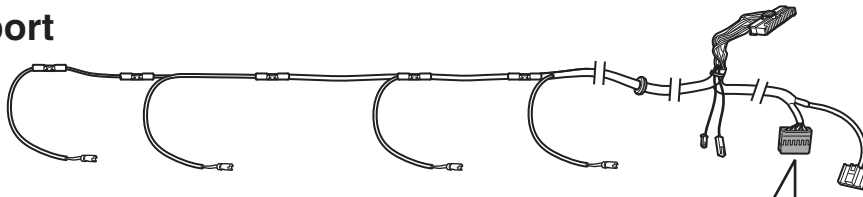

T-sport

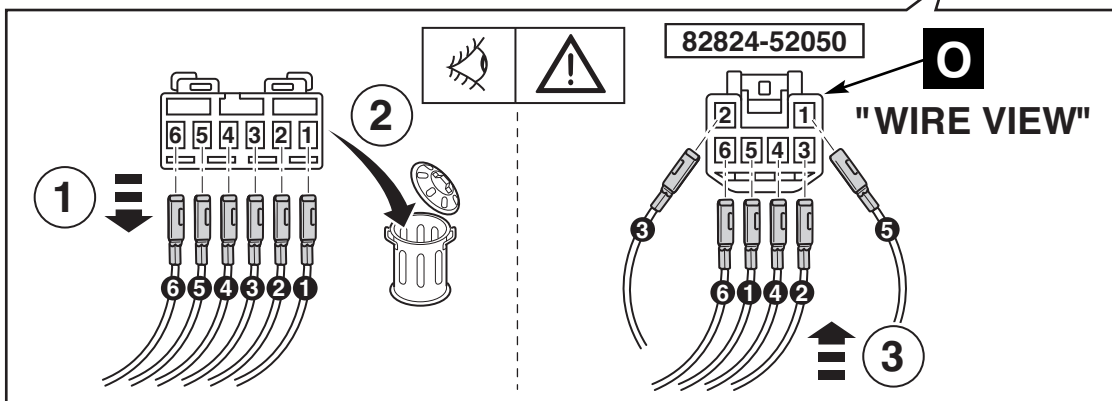
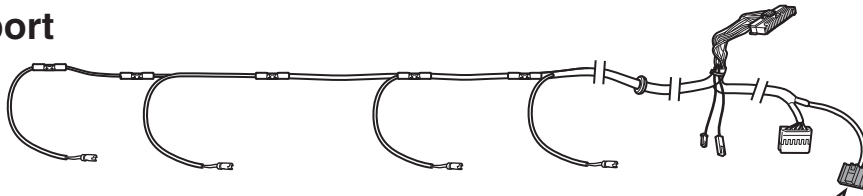

0





2.9-7.8 Nm

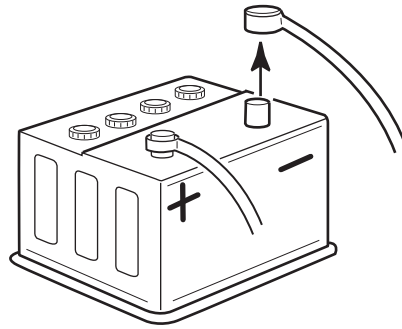

90 Sec.



1



2

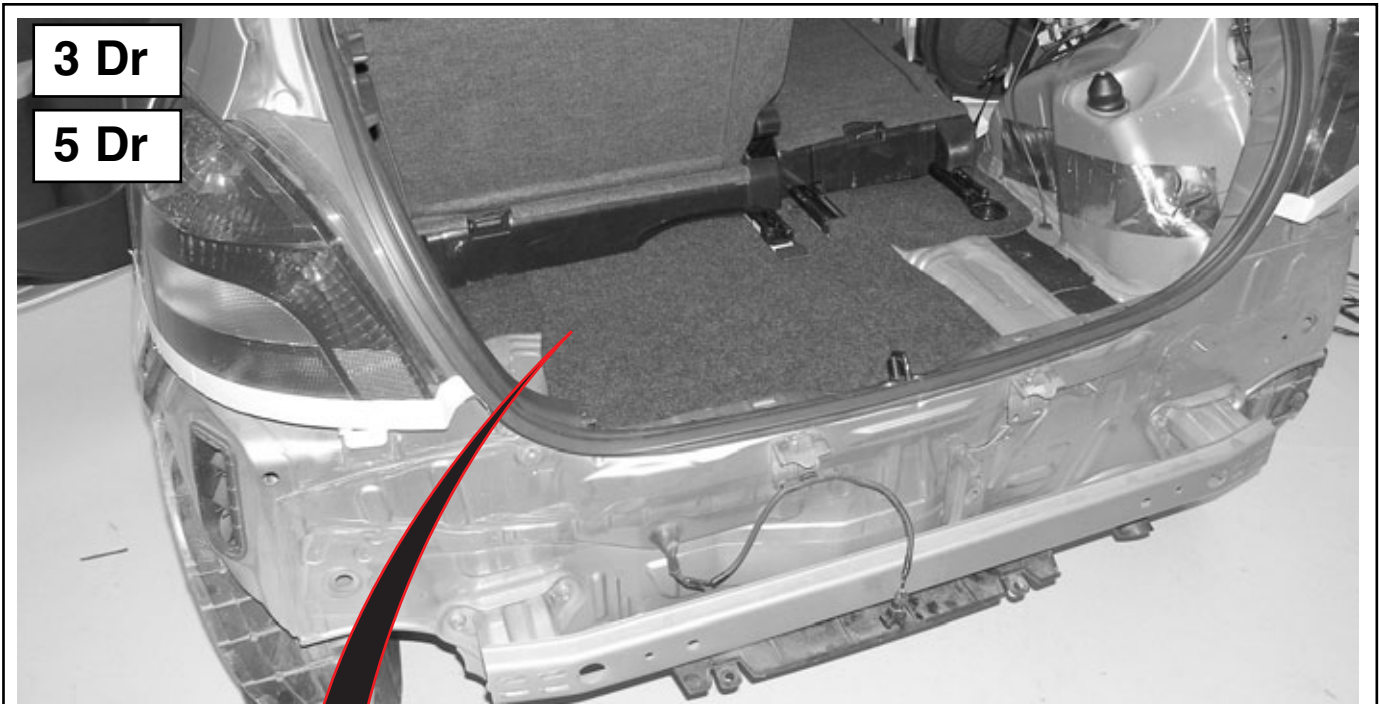

3 Dr
5 Dr

5 Dr	✓	4
3 Dr	✗	

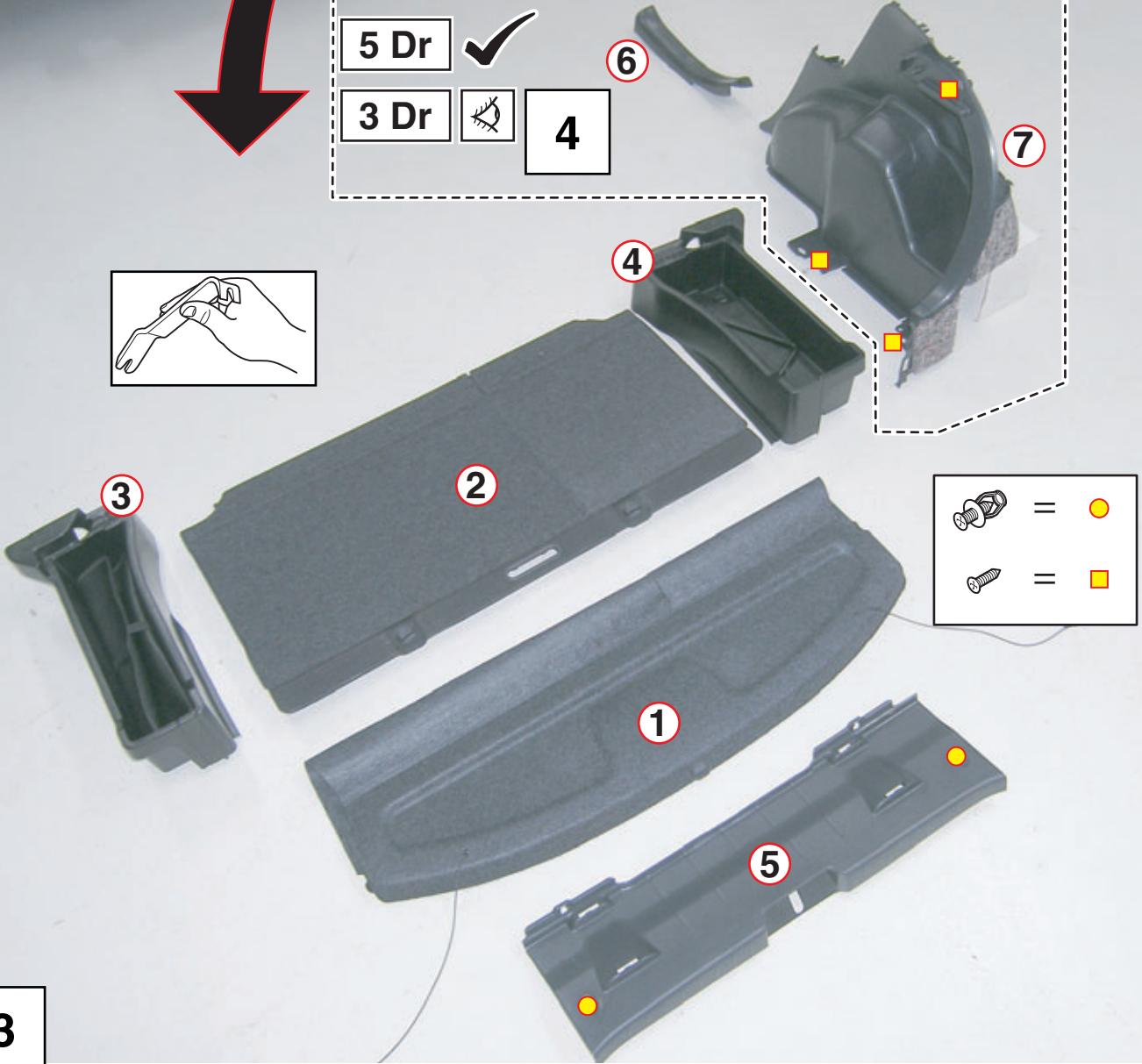
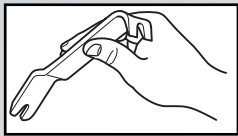

3

3 Dr

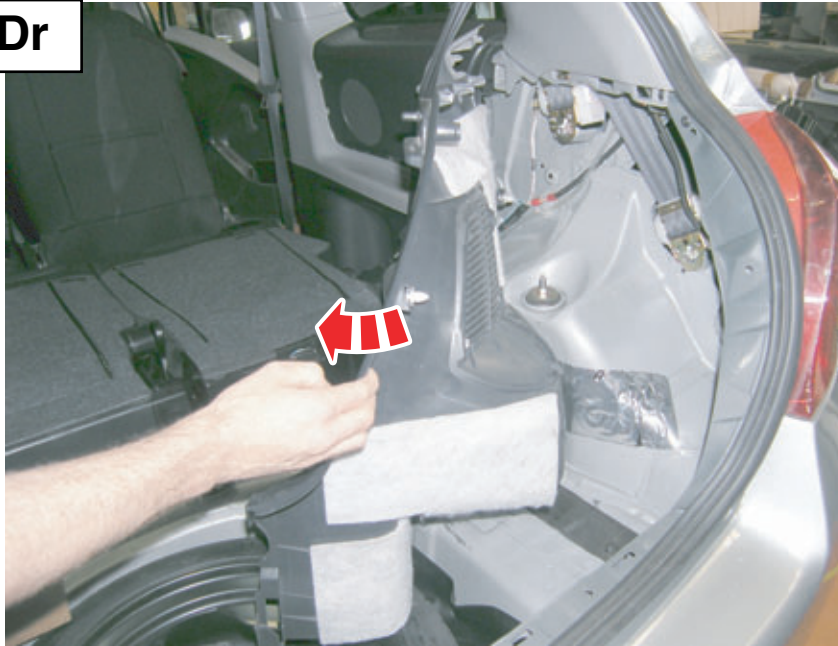

4

INSIDE BUMPER

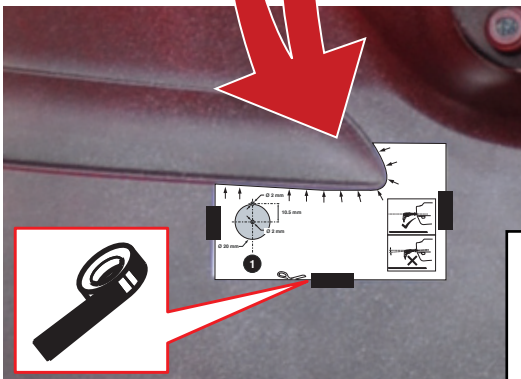

18 of 22
19 of 22

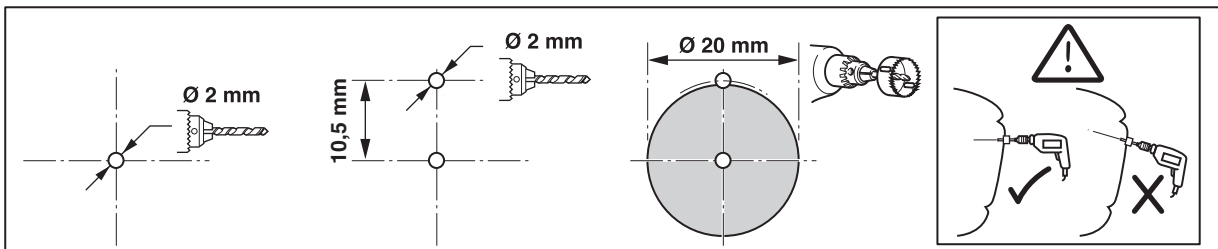
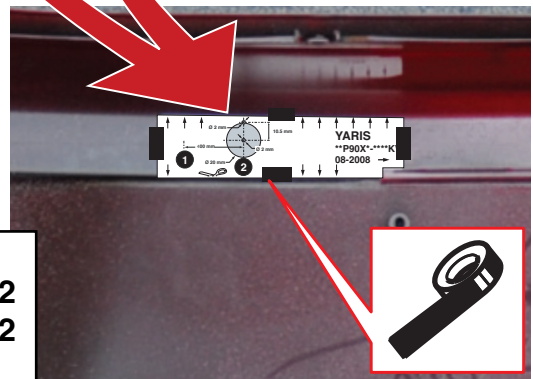

5



"T-sport" bumper

OUTSIDE BUMPER

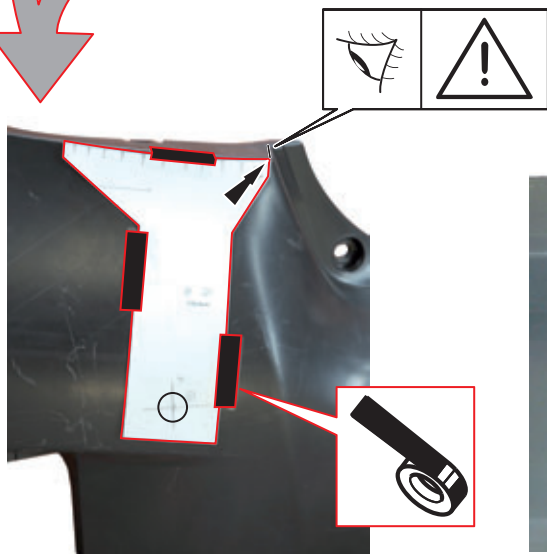
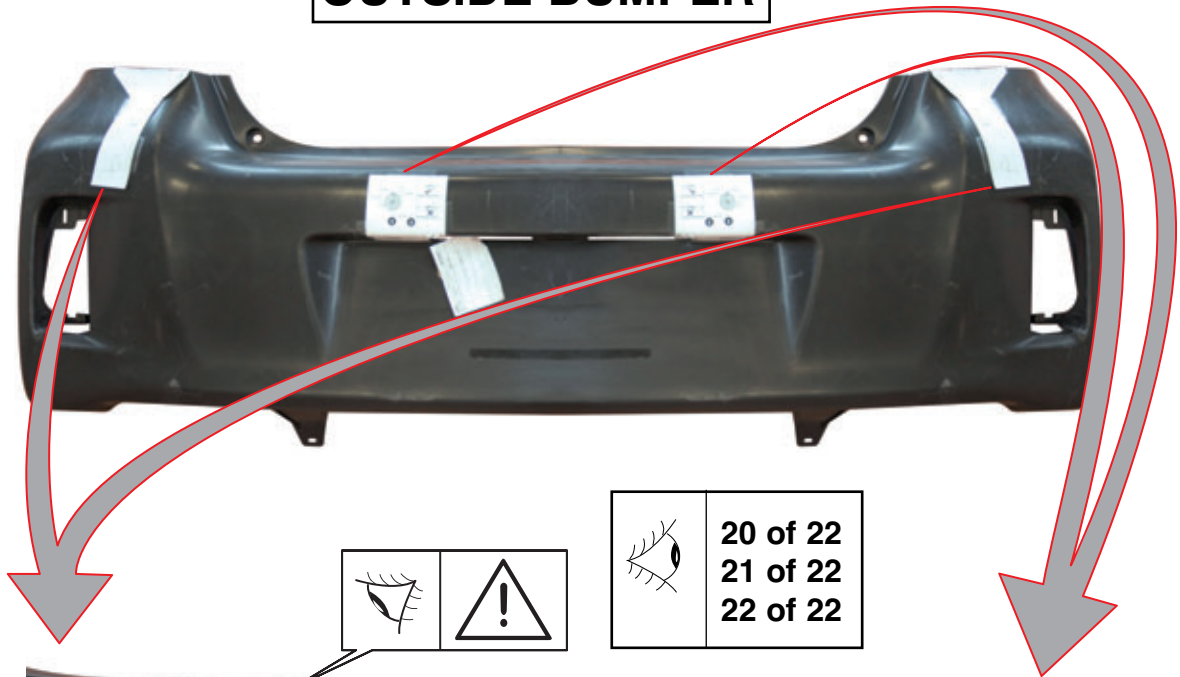

	20 of 22
	21 of 22
	22 of 22

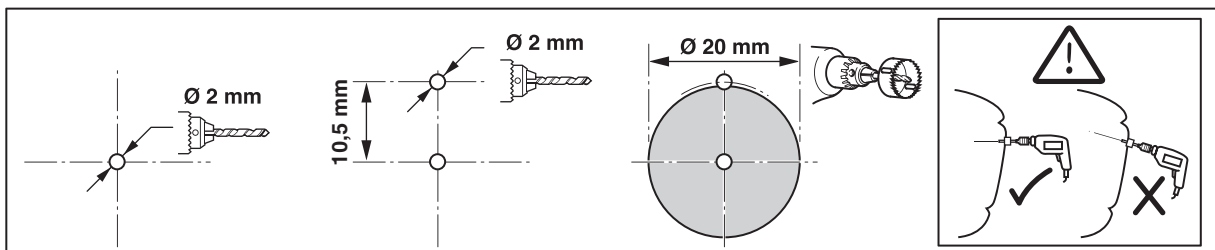
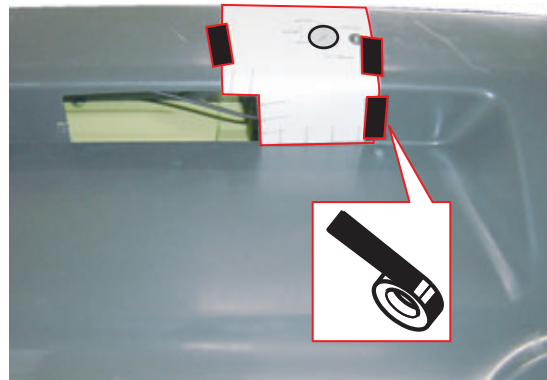

6

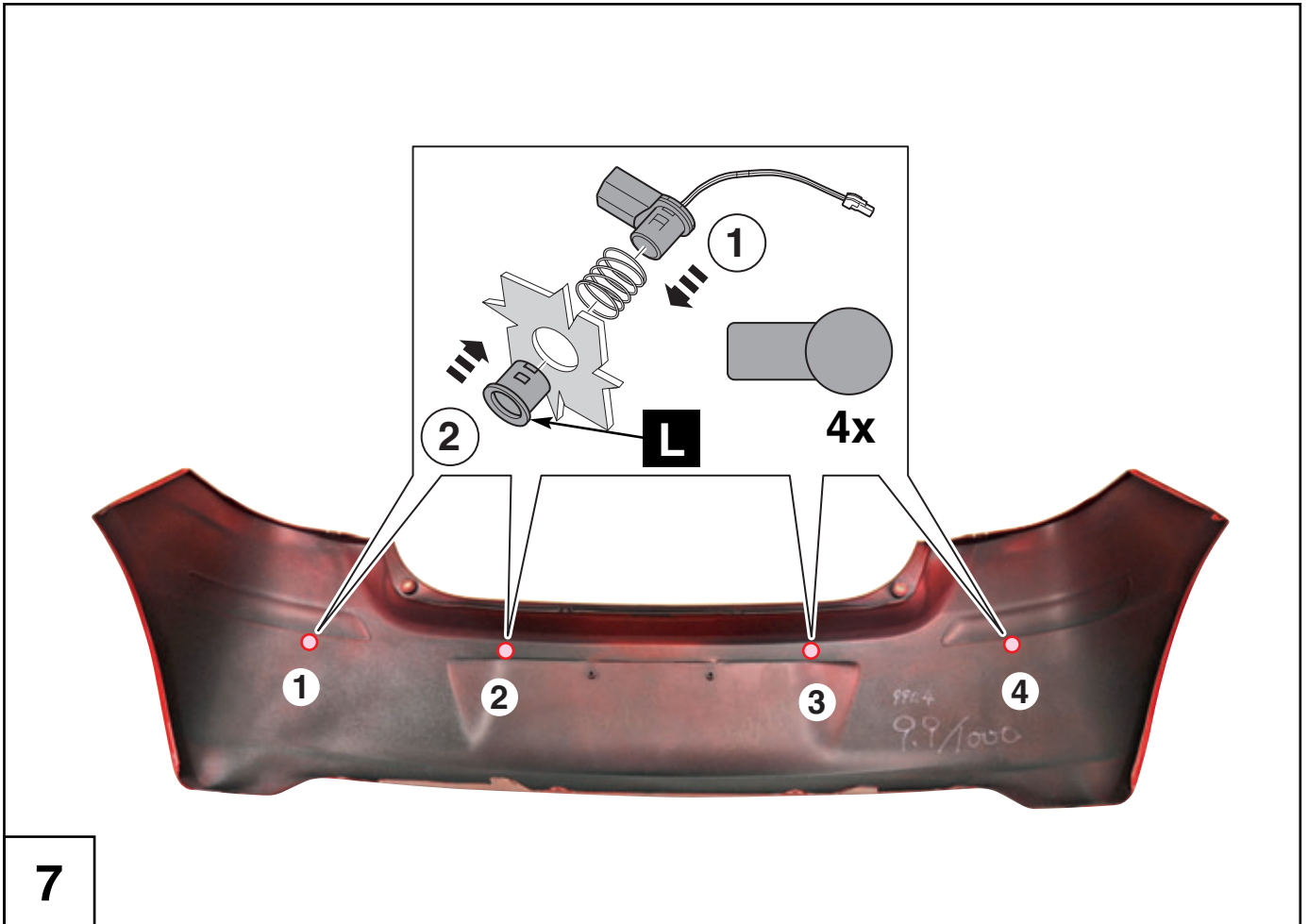

7

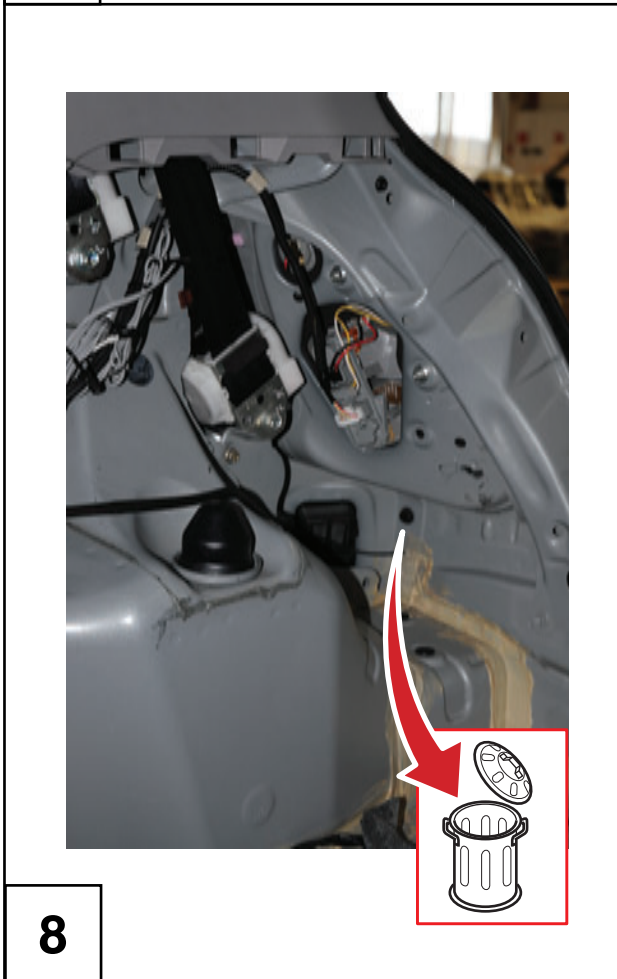

8

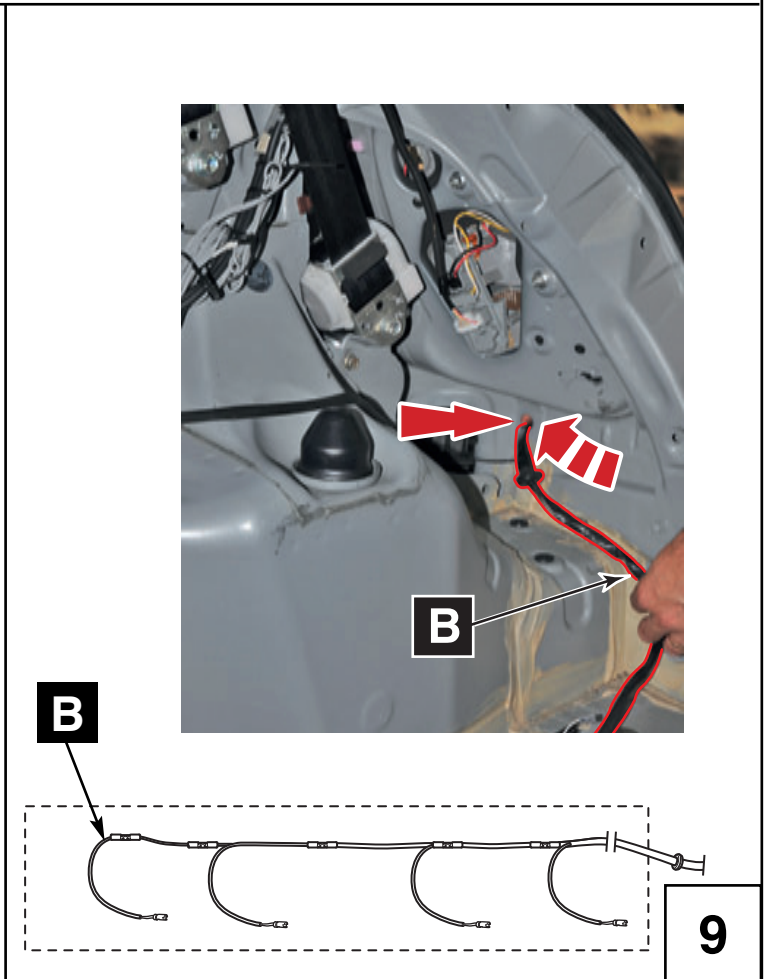

9

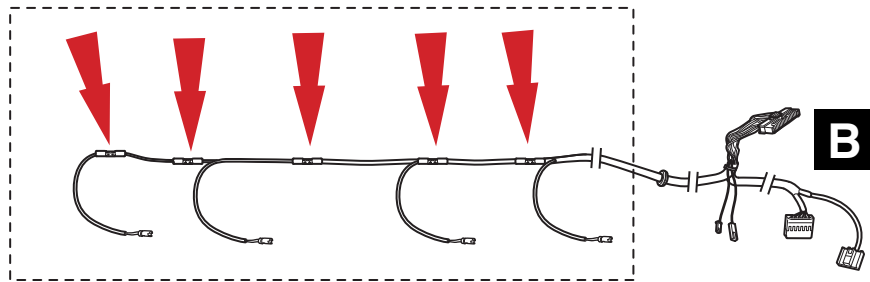
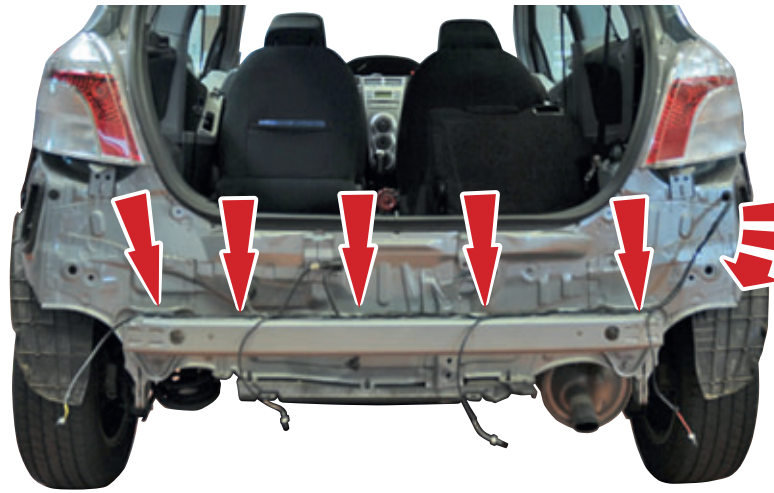

10



J3



11

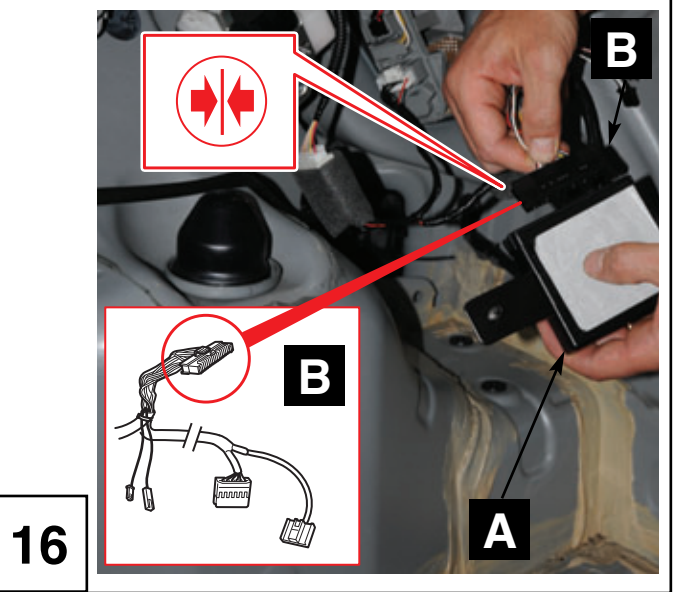
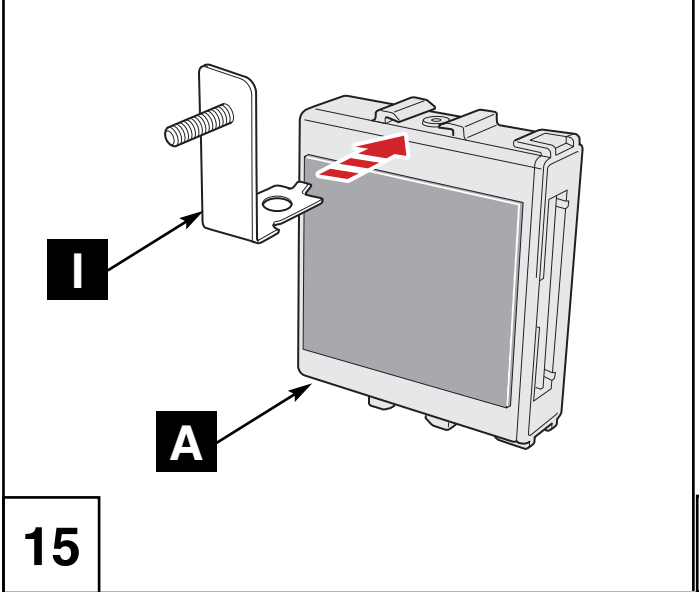
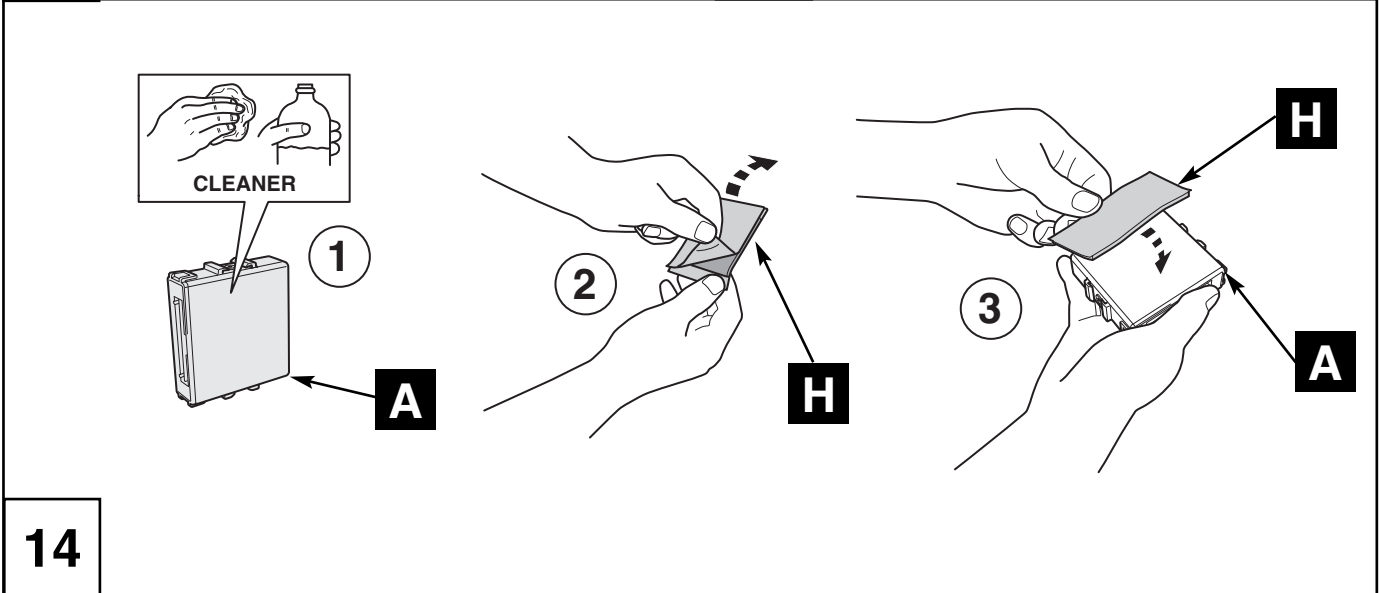
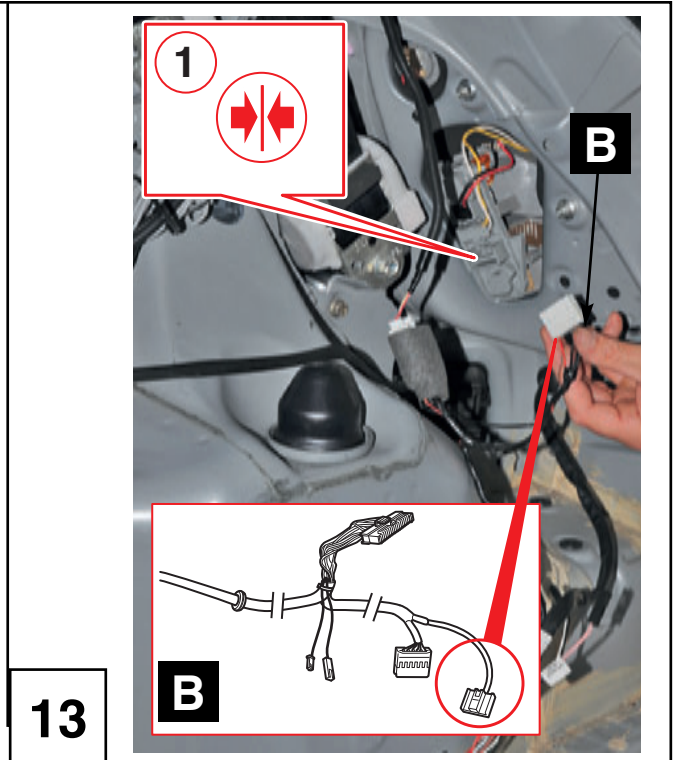
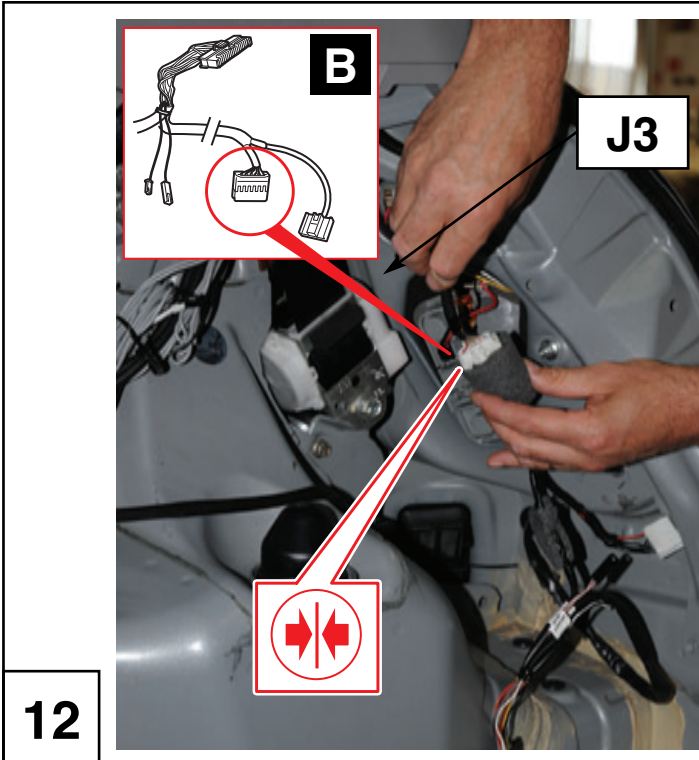

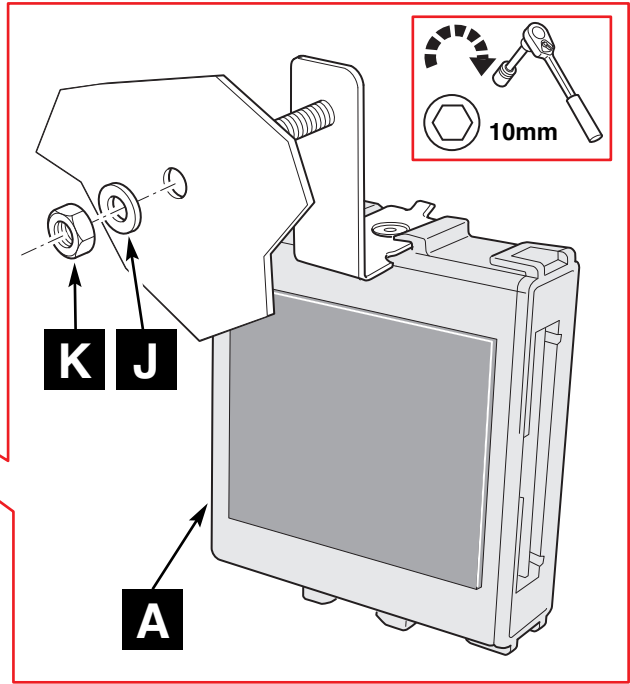

17

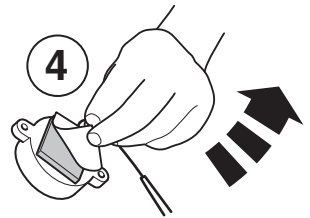
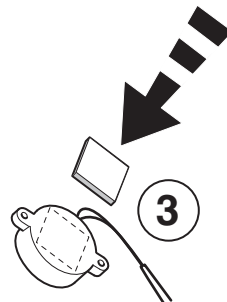
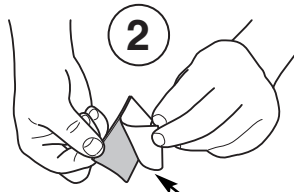
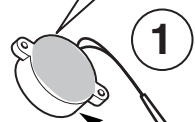

18

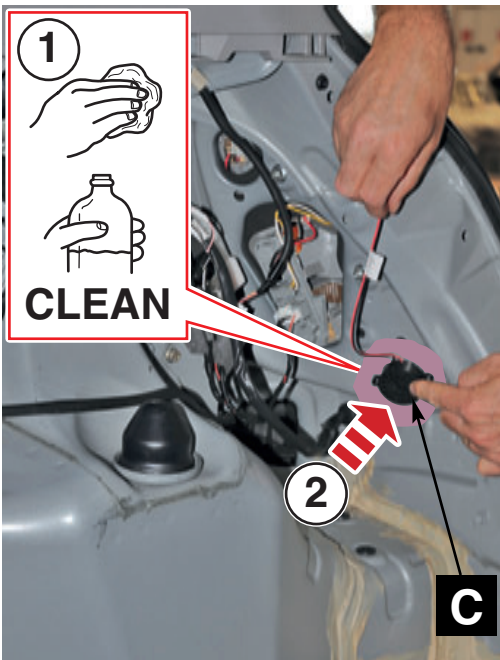

19

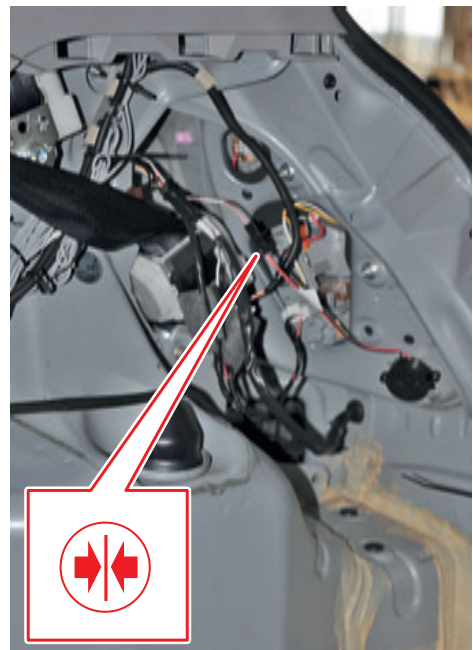

20

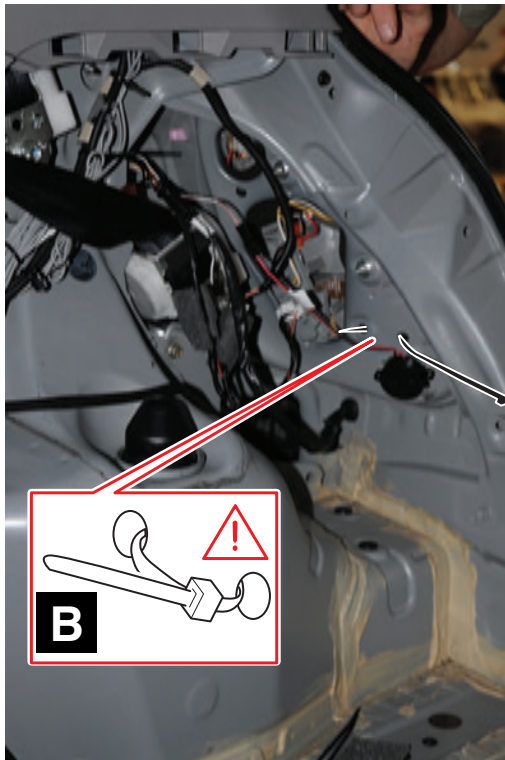

21

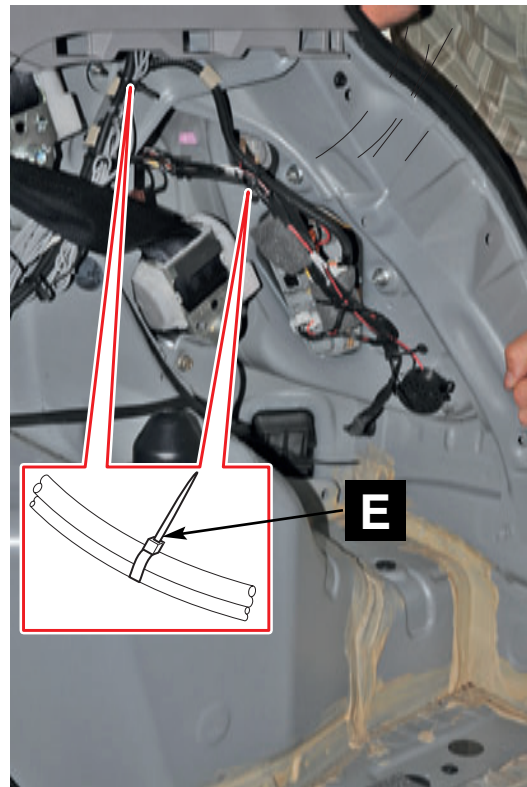

22

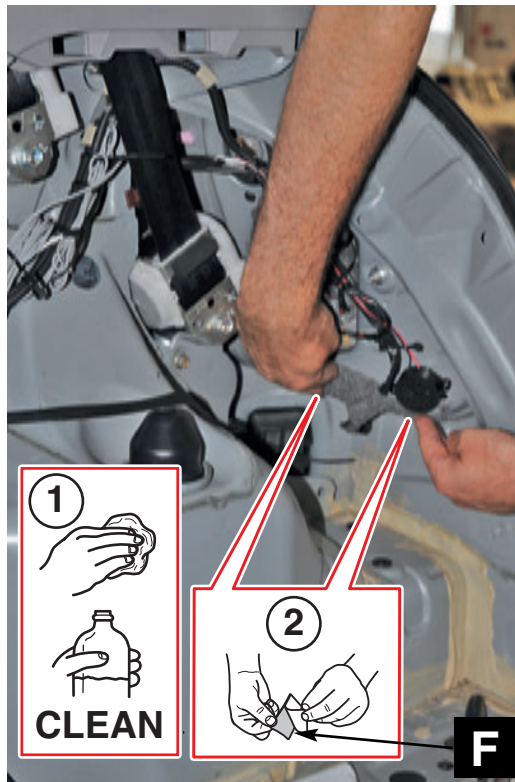

23

24

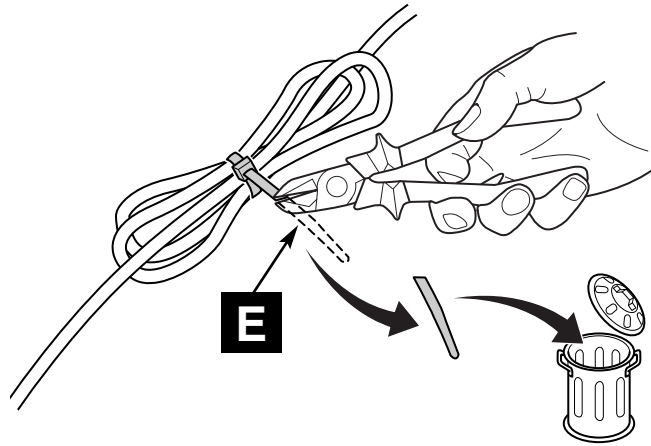

Optional

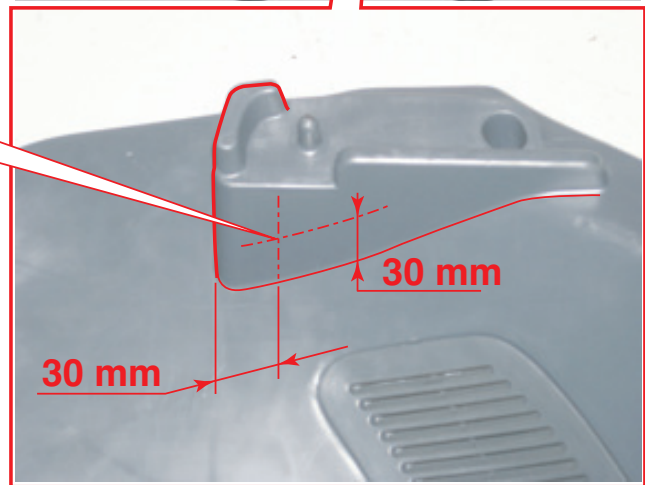
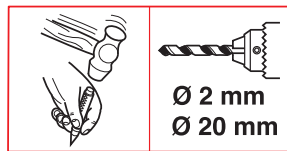
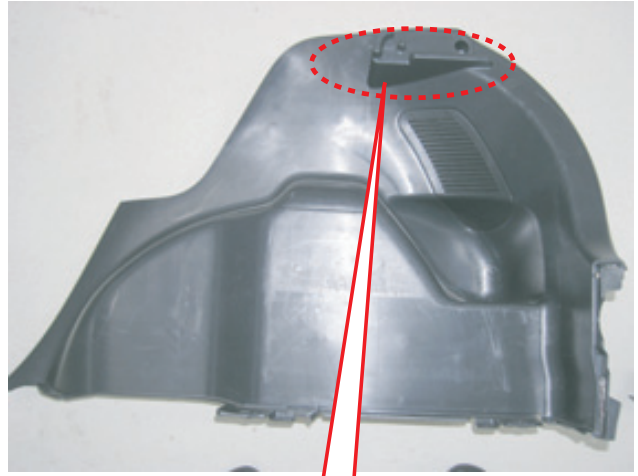

25

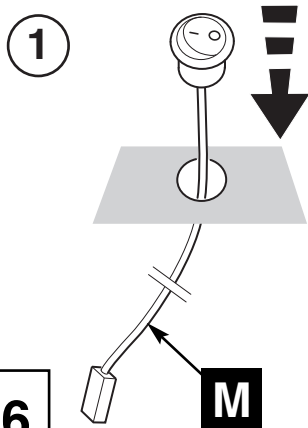

26

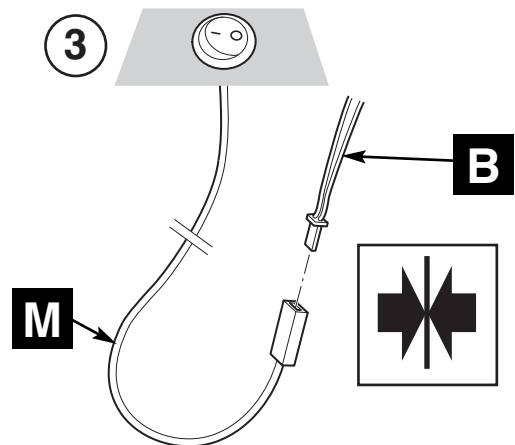
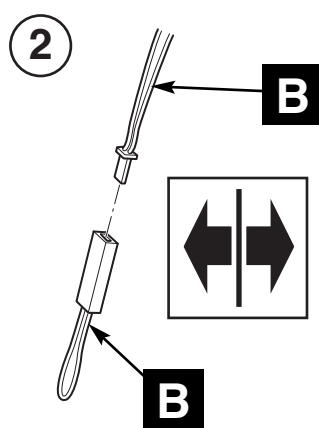

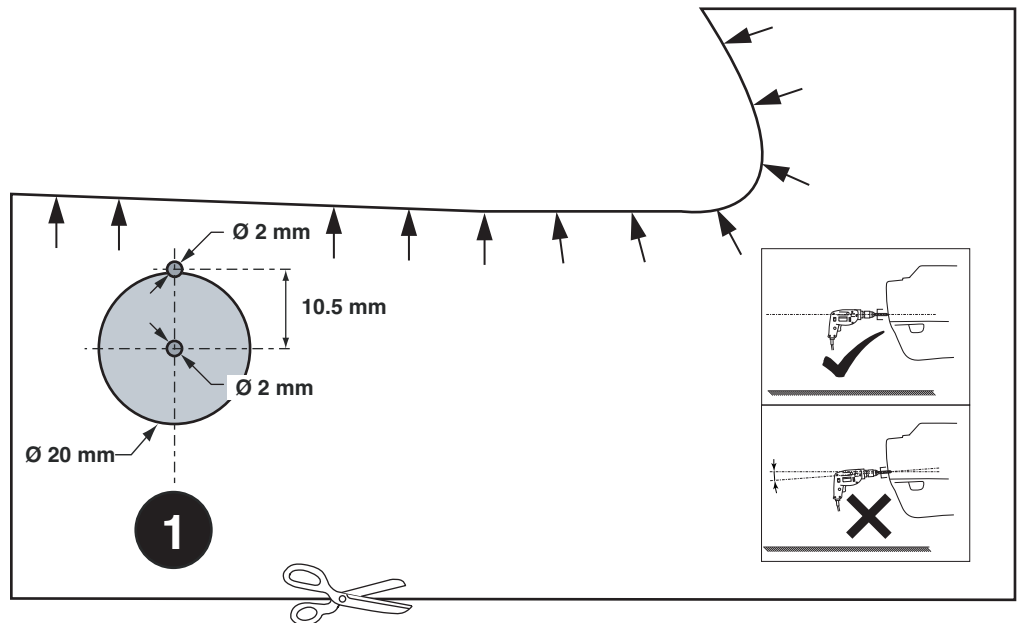
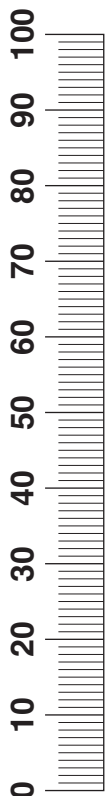
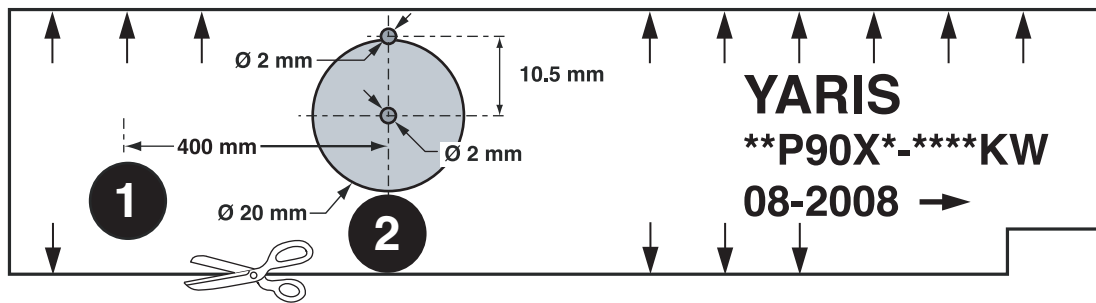
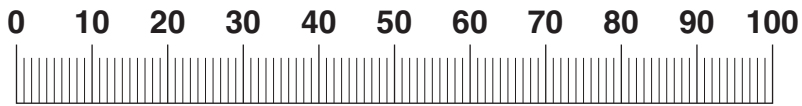

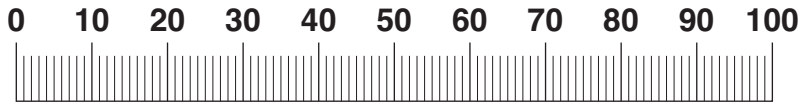

CHECK SIZE

**Print 100%
Check with Rulers
before use.**

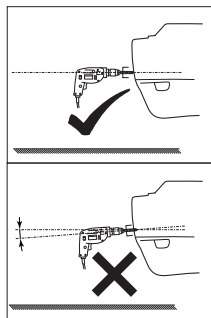
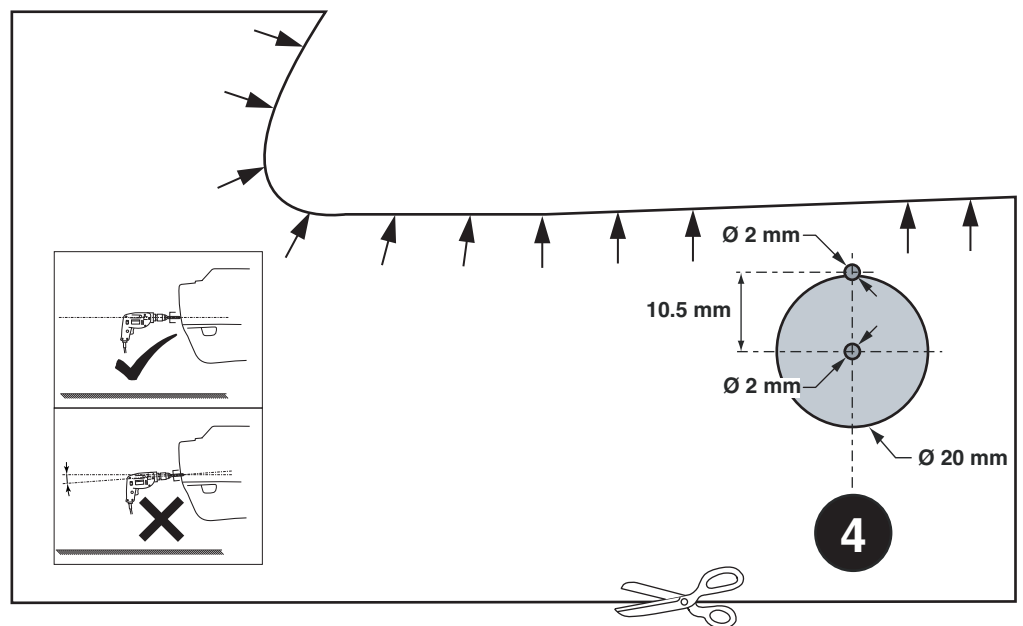
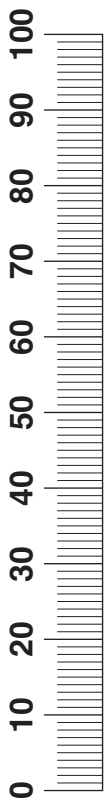
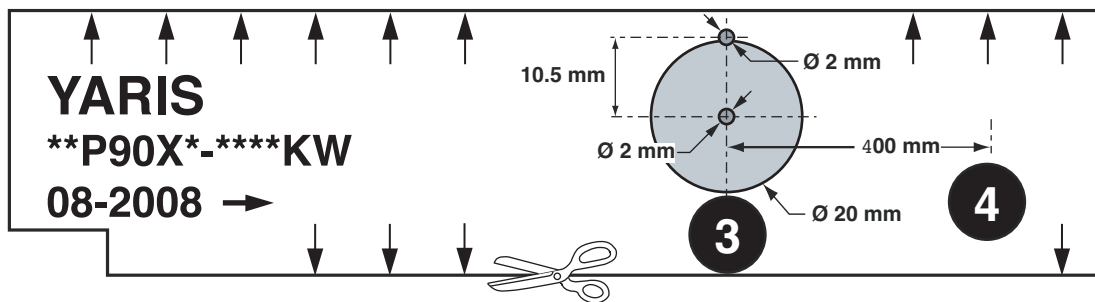



CHECK SIZE

Print 100%
Check with Rulers
before use.

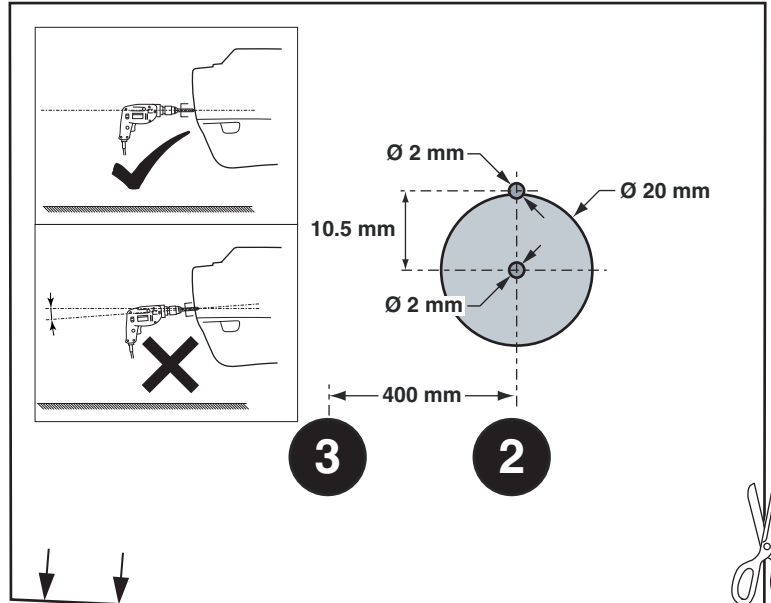

**T-Sport
YARIS
P90*-*GKW
11-2005 →**

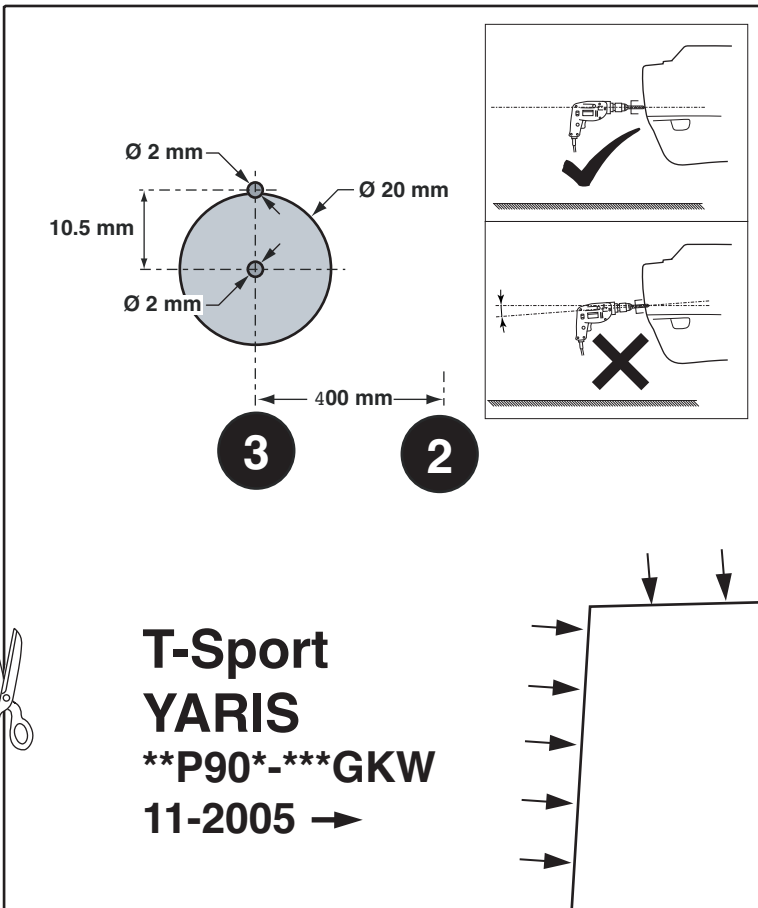

**T-Sport
YARIS
P90*-*GKW
11-2005 →**

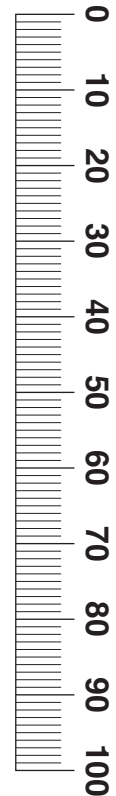

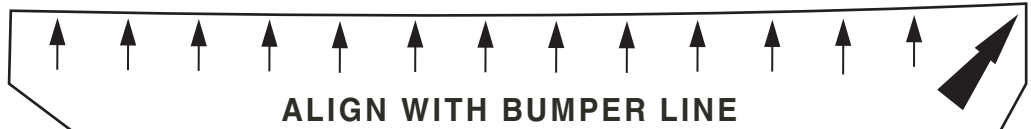

ALIGN WITH BUMPER LINE



LH SIDE

G1

TPA: YES



CHECK SIZE

Print 100%
Check with Rulers
before use.

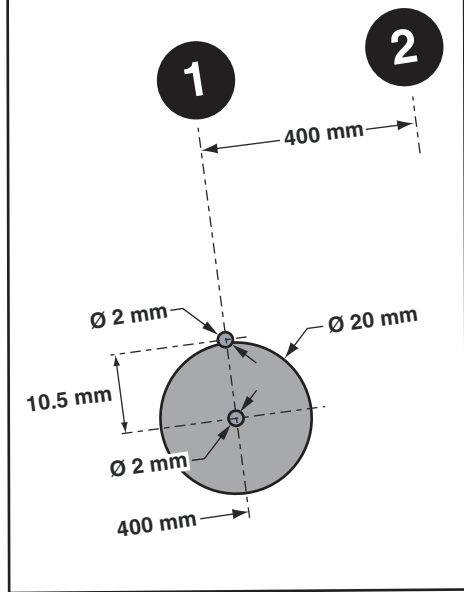
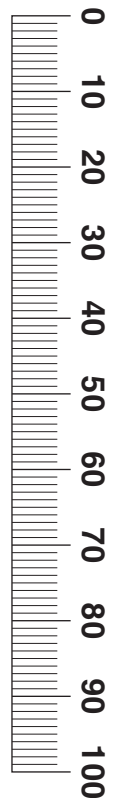
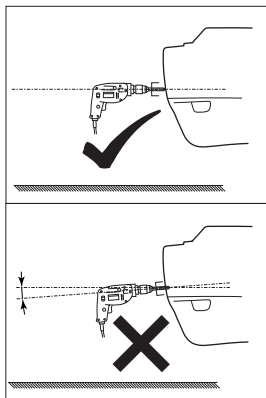

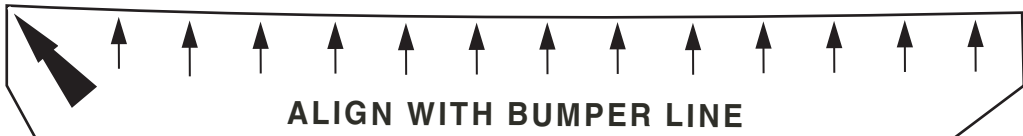

RH SIDE

H1

TPA: YES

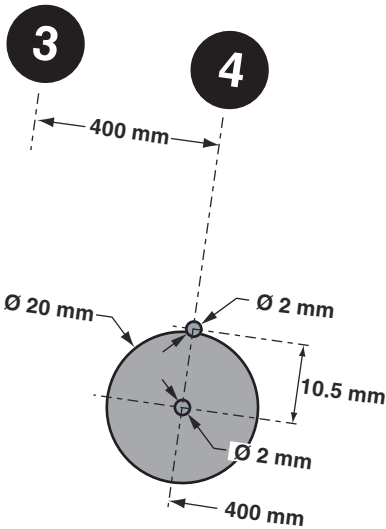
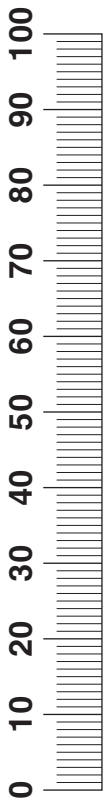



CHECK SIZE

Print 100%
Check with Rulers
before use.

