



Auris

Rearskirt twin pipe

Installation instructions

Model year: 2006
Vehicle code: **E15**-*****W
Part number: PZ439-E9463-AB (only compatible with PZ439-E9715-00)
PZ439-E9464-AB (only compatible with PZ439-E9716-00)



Weight: 1.4 kg



Installation time: 1,15 hours + 0,5 hours (Silencer)

Manual reference number: AIM 000 788-4

Revision Record

Rev. No.	Date	Page	Picture	Update	New	Deleted Steps
2	05-01-07	1,3		X		
3	07-05-07	1,4		X		
4	10-07-07	3		X		

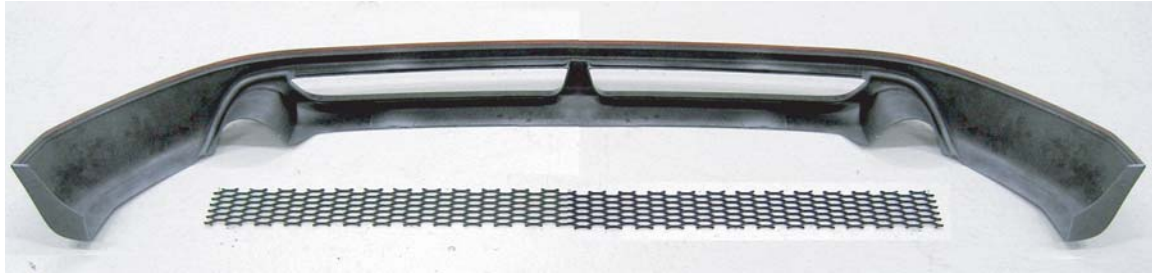
A

1x

B

1x

C

1x

D

1x

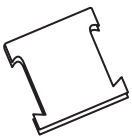
E

12x

F

2x

G

2x

H

2x

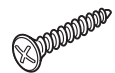
I

2x

	TESA 4651 20mm 3M 3960 19mm		Sikkens M600 and Spiess Hecker 7799 CLEANER		
 10 mm 12 mm		 SAND P80	 Ø 4mm		

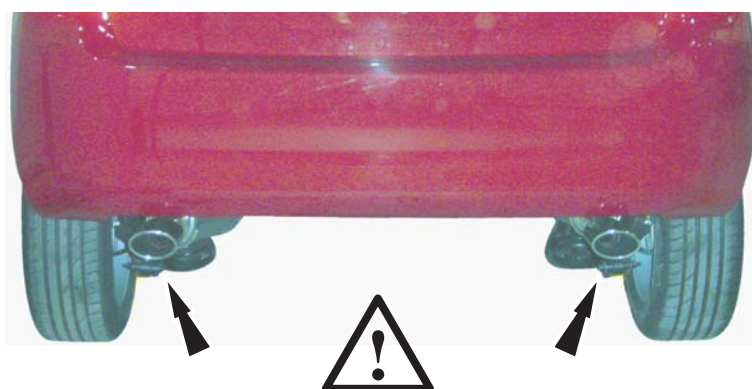

- | | | |
|---|--|-------------------------------|
| 1 | | AIM 000 729
PZ439-E9715-00 |
| | | AIM 000 969
PZ439-E9716-00 |
| 2 | | 2-19 |

1

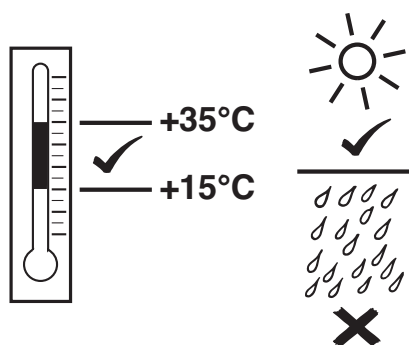

2

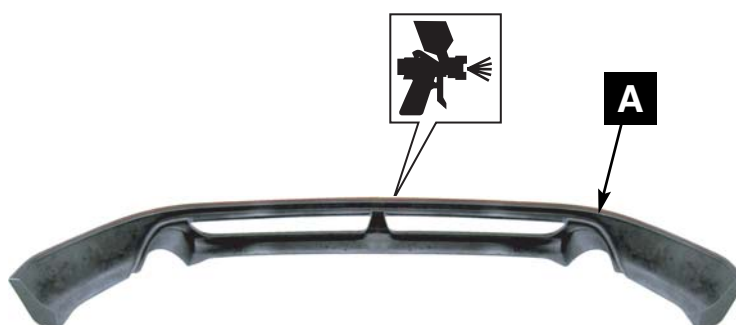

3

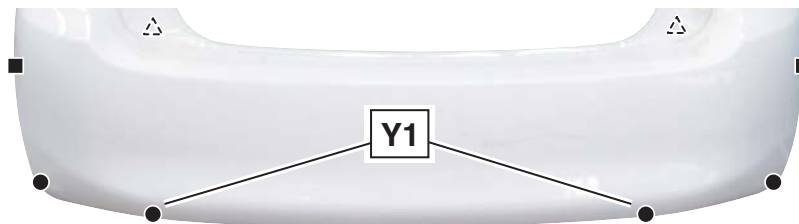
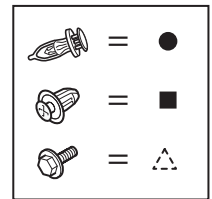
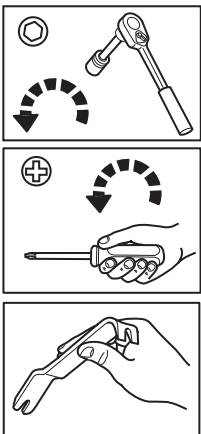

4

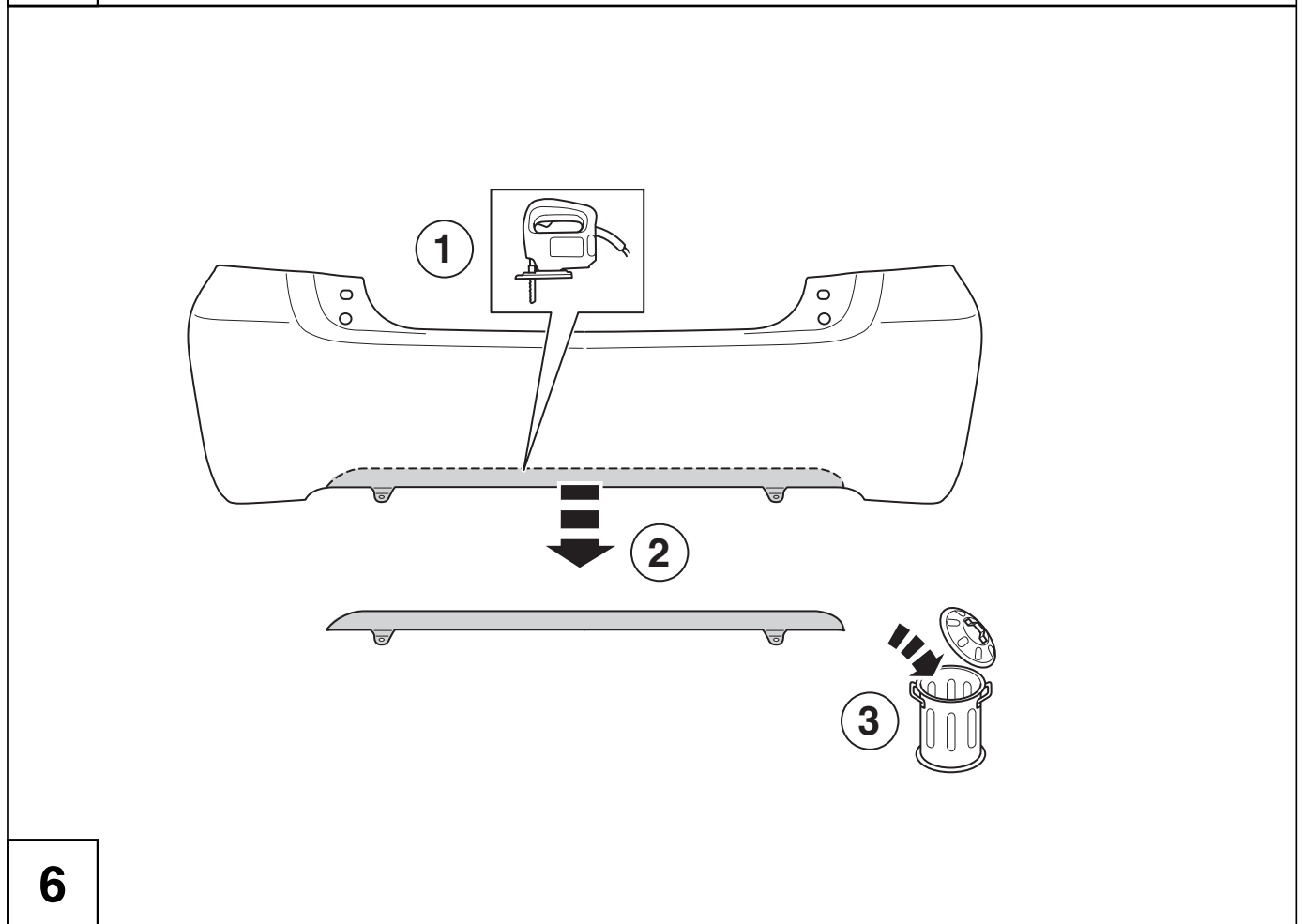
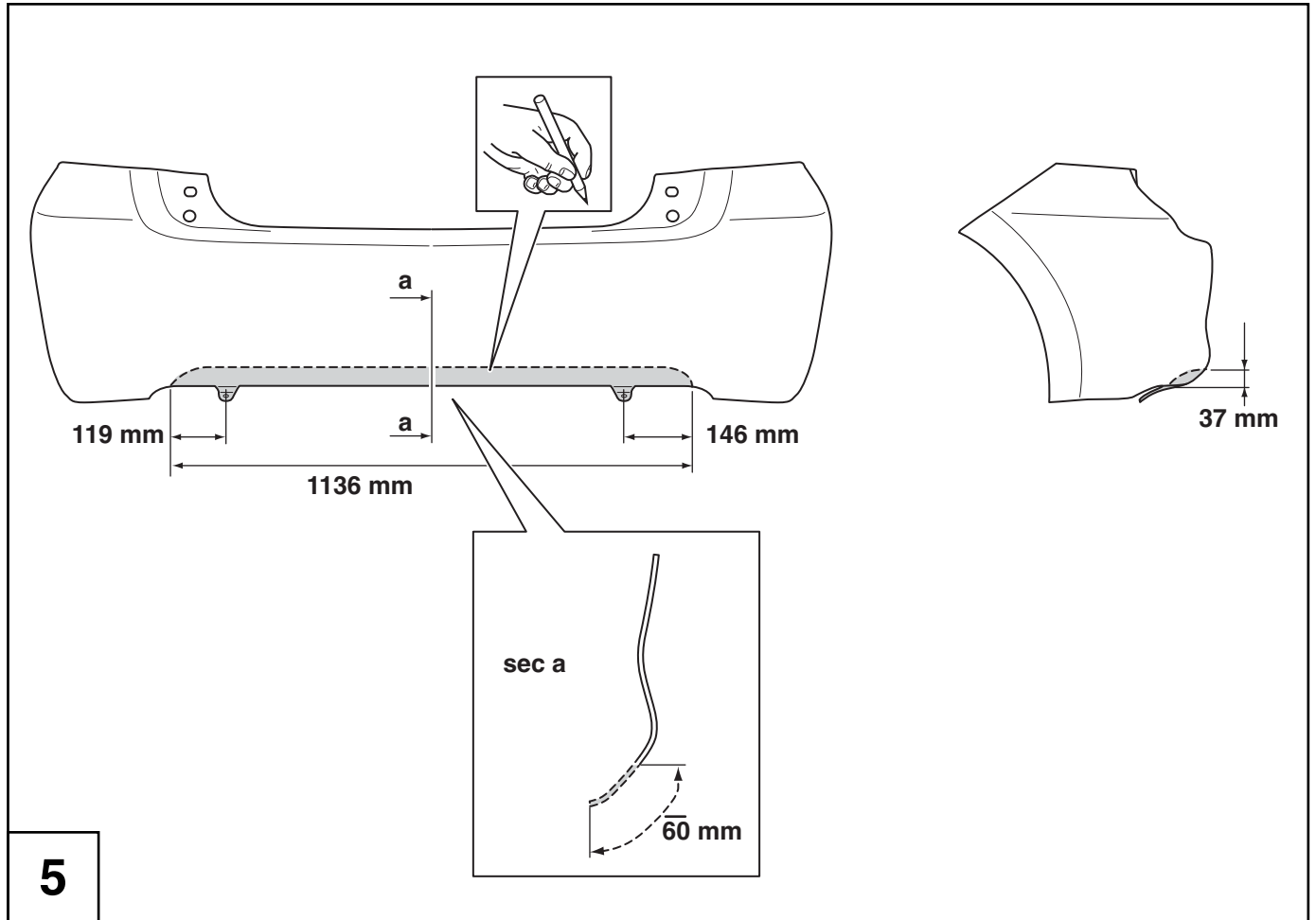

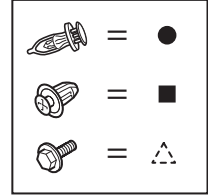
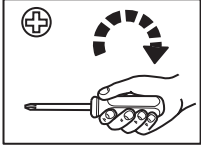
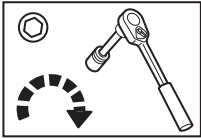

7

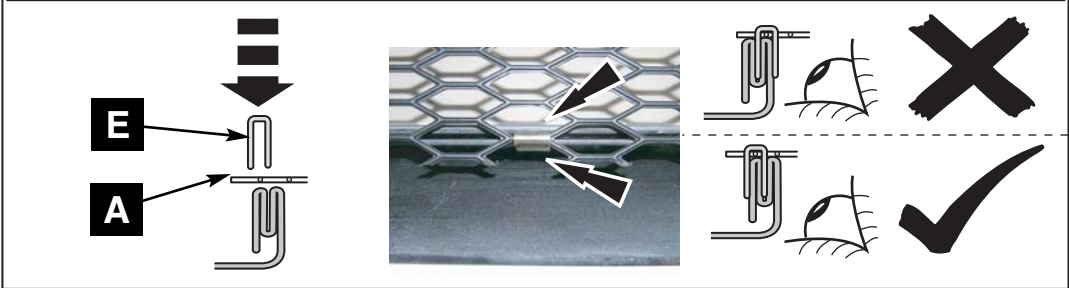
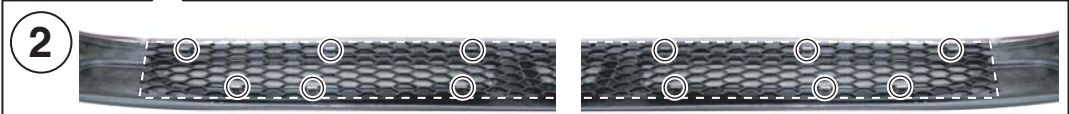
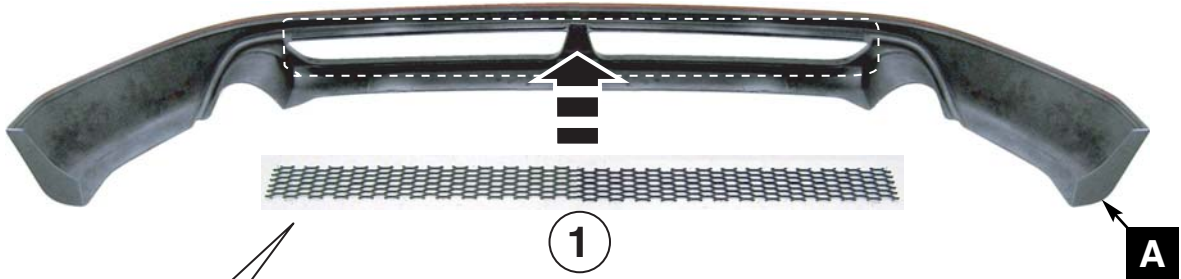

8

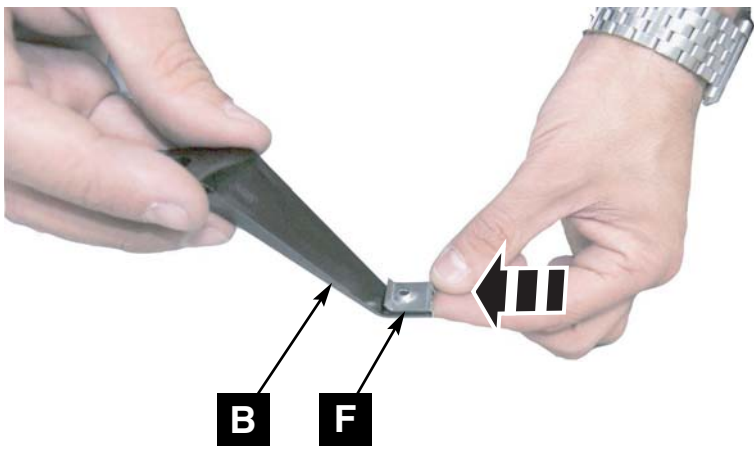

9

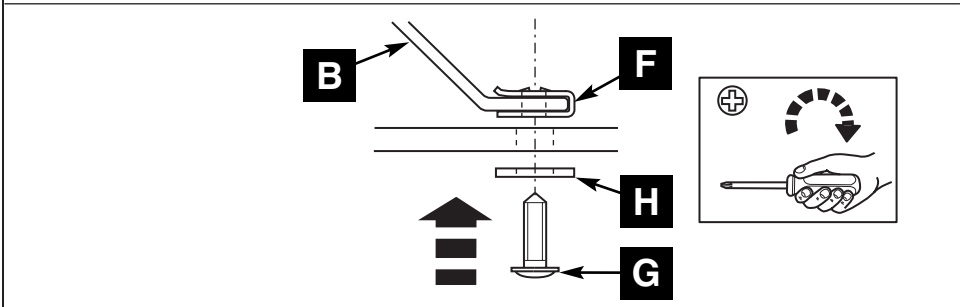
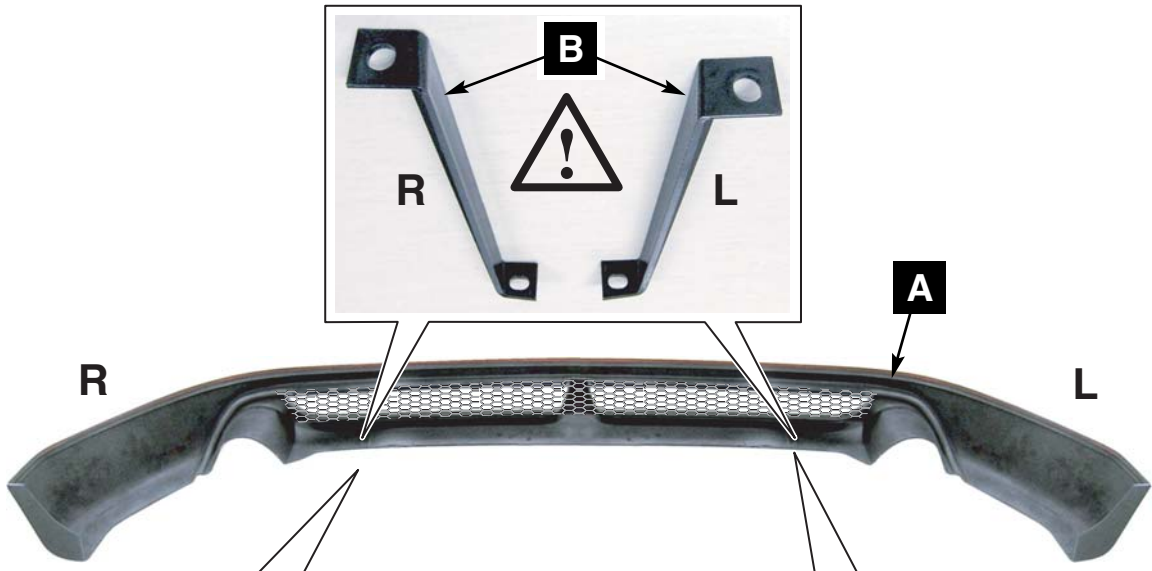

10



11

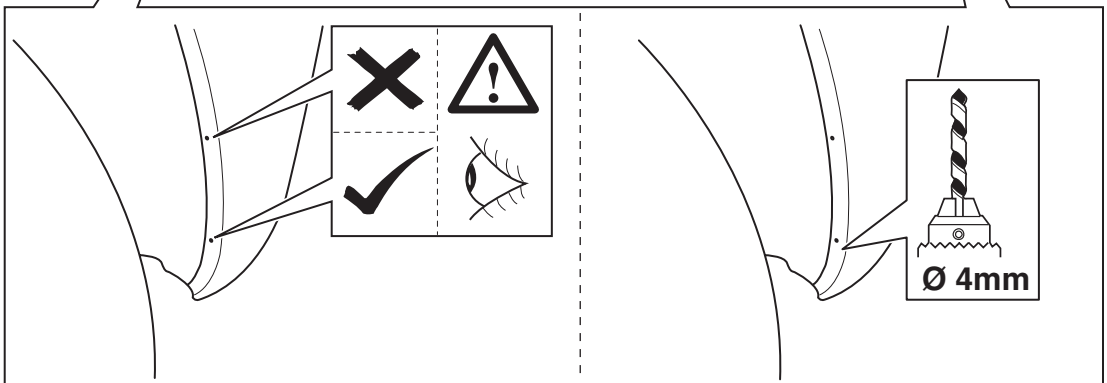

12

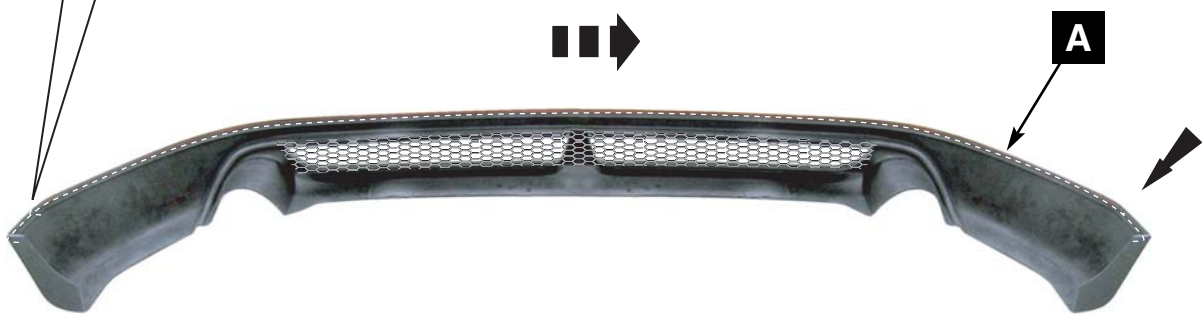
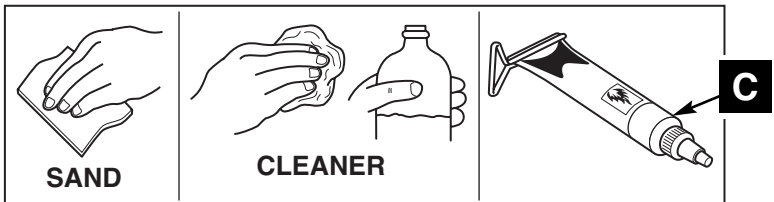

13

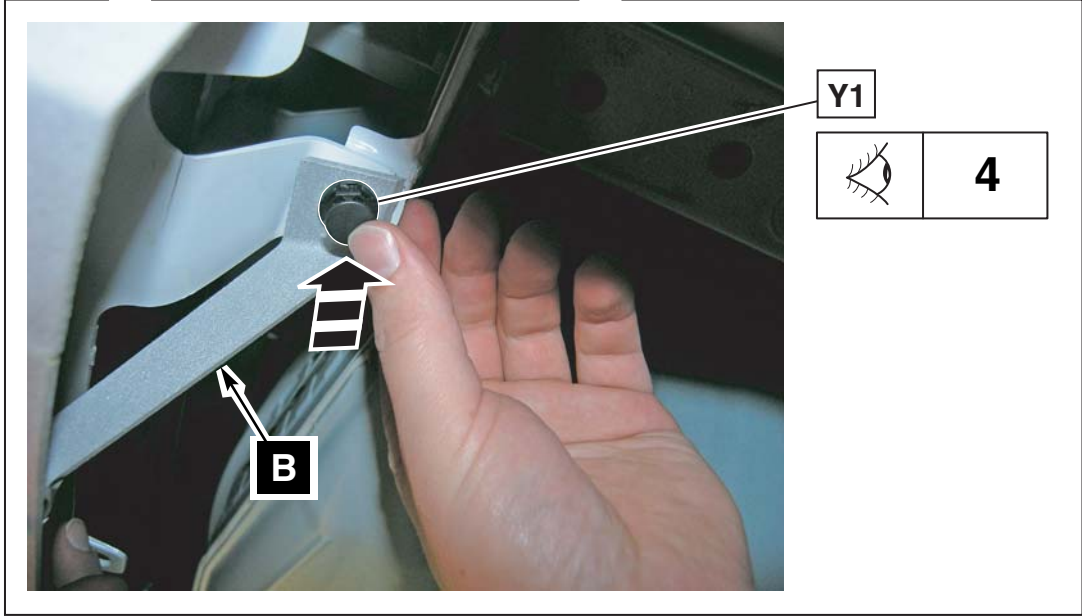
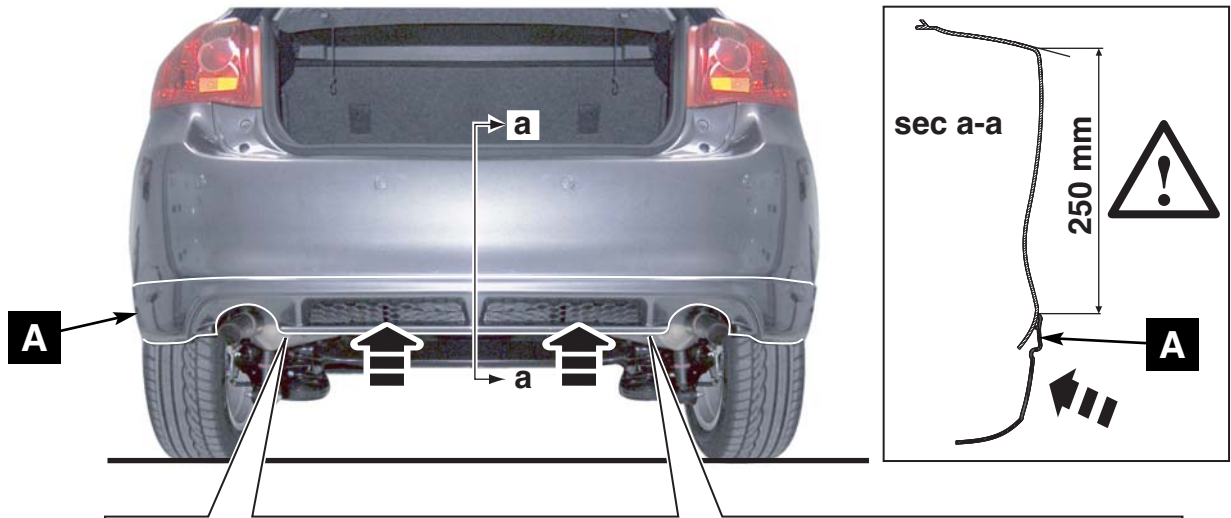

14

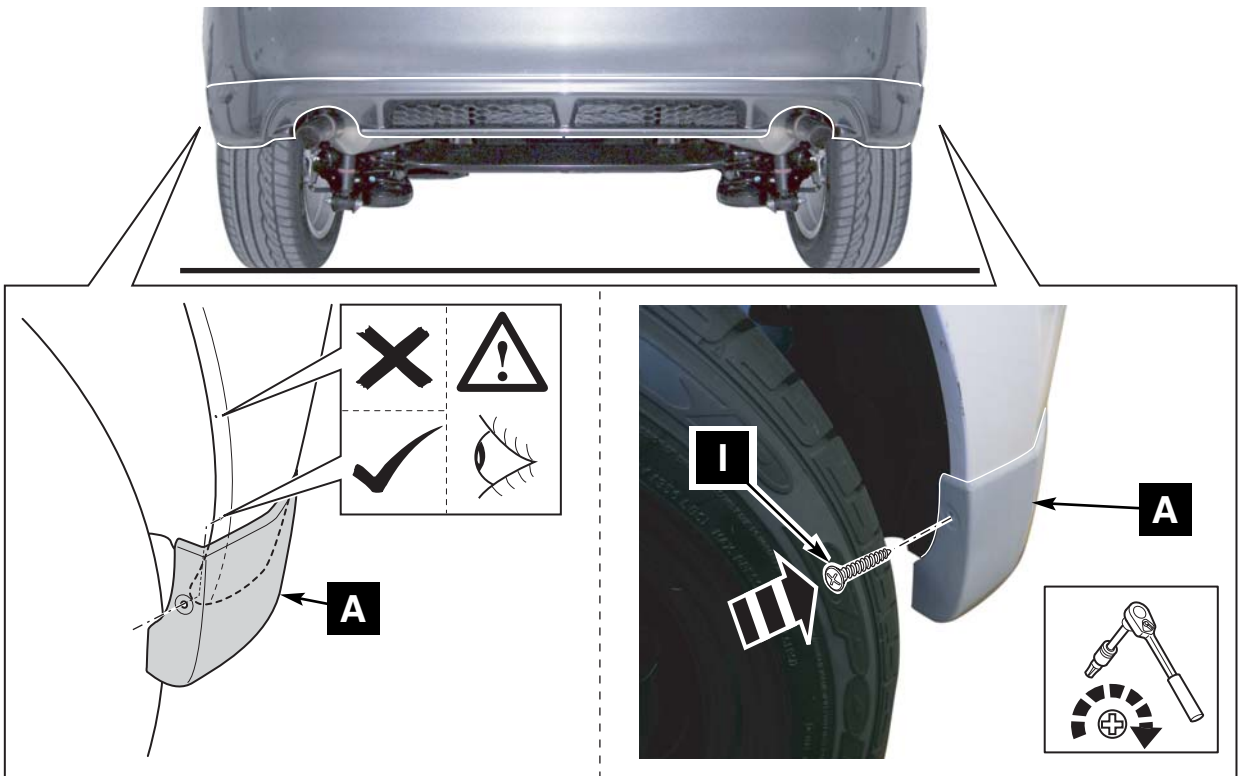

15

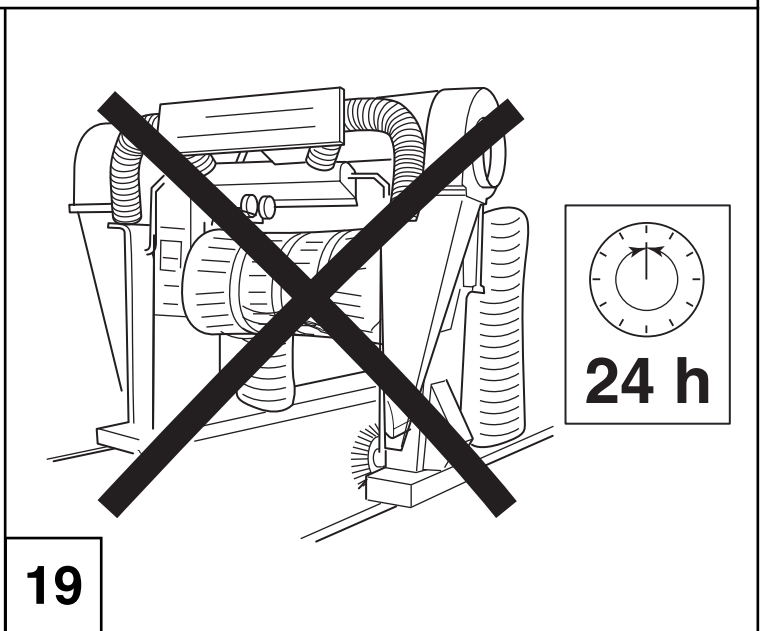
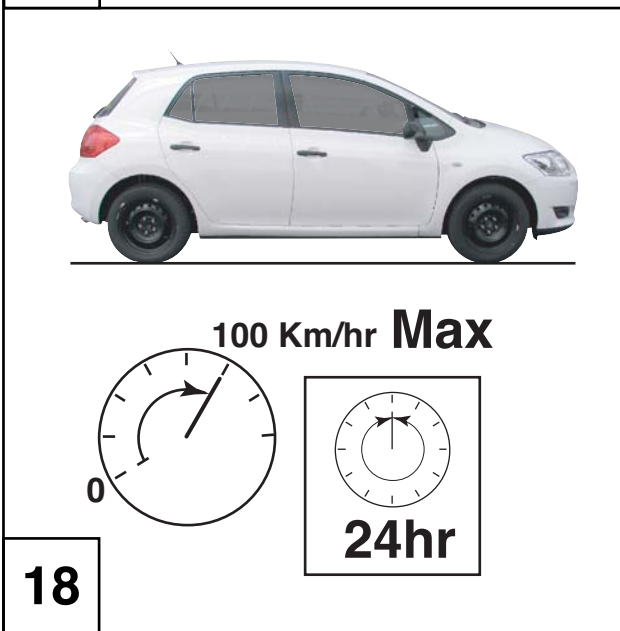
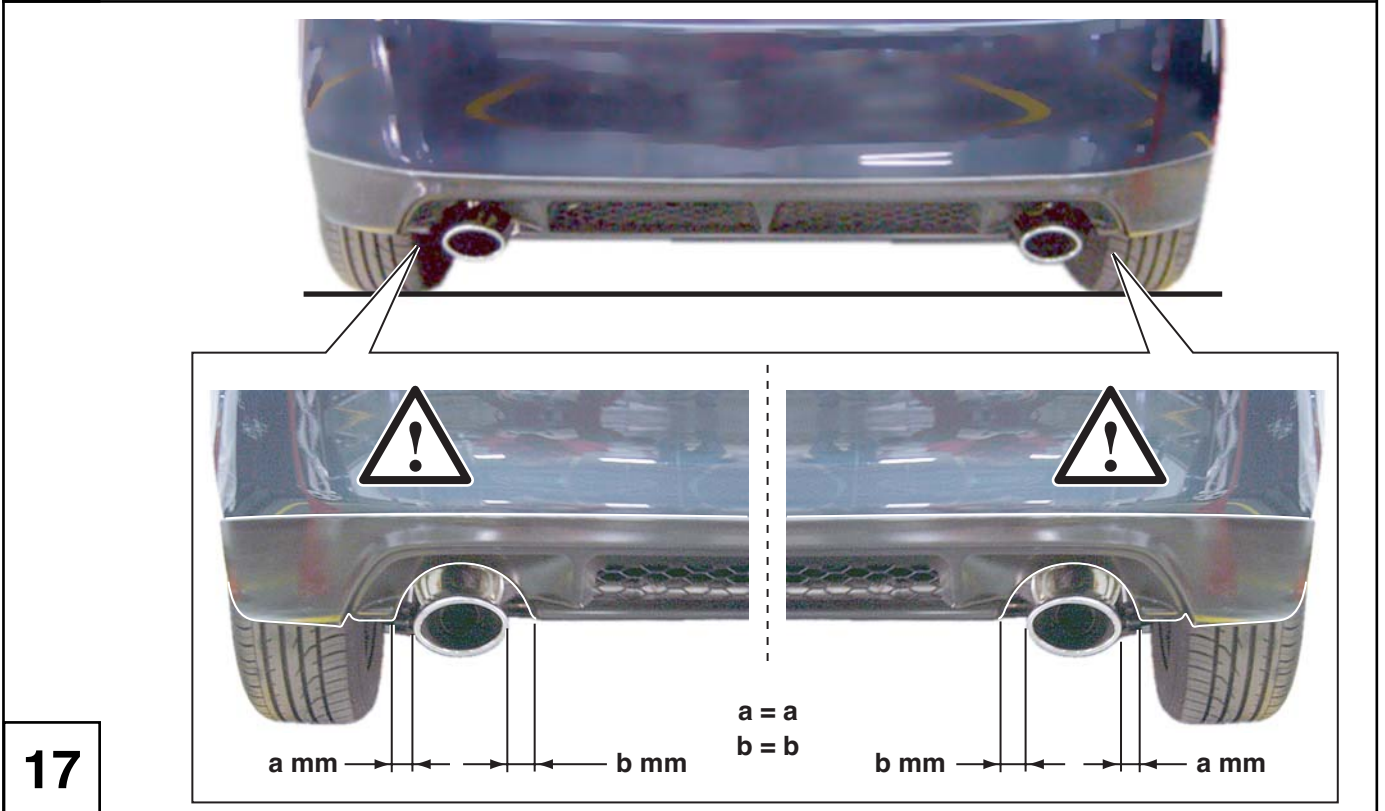
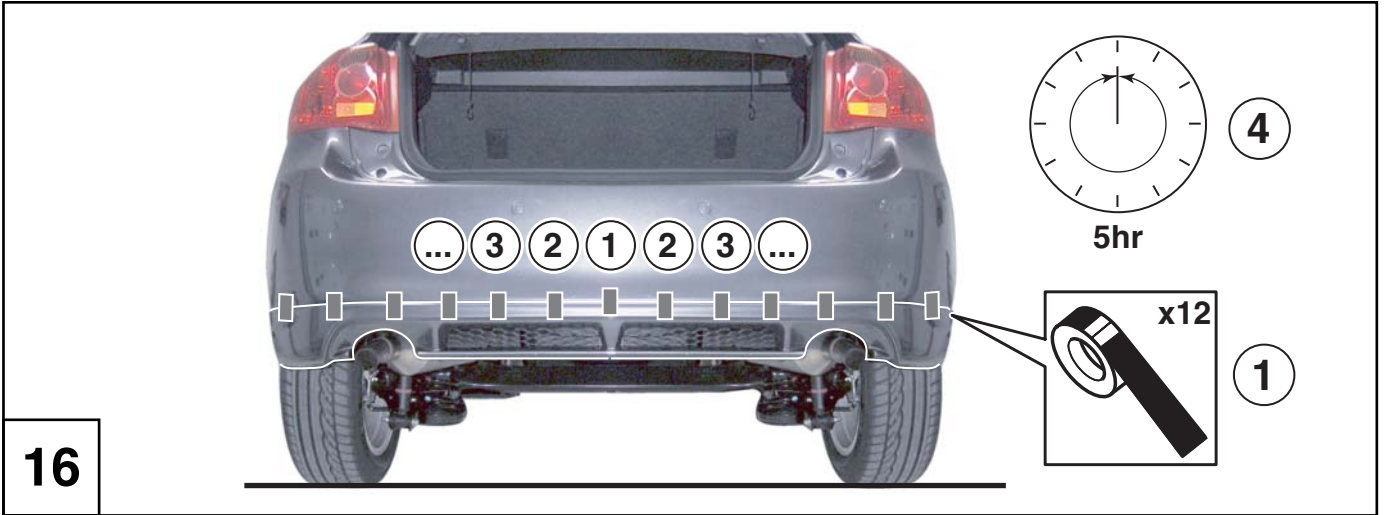

D

Hinweise zur Lackierung !!!

- 1) **Schleifen:** Schleifen der Teile mit Scotchbrite
- 2) **Reinigung:** Reinigen mit Silikonentferner (z.B. **Toyota Hydro Cleaner PZ469-A0002-50**)
Abwischen des Teiles mit einem Staubbindetuch (z.B. **Fa. BERNER Art. 85910.1**)
- 3) **Decklackierung unter Verwendung von :**
z.B. **Toyota Hydro Base coat, ...**
- 4) **Klarlackierung unter Verwendung von :**
z.B. **Toyota 2K HS Clear PZ469-C0002-50, ...**
- 5) **Trocknung:**
- Bei max. 40°C für mind. 1 Std. oder Lagerung bei Raumtemperatur über Nacht (Staubtrocken)
Lagerung für mind. 24 Std. bei Raumtemperatur (vollkommen ausgehärtet)
- 6) **Polieren:**
Sichtbare Staubeinschlüsse mit Schleifblüten (z.B. **Fa. 3M 13444**) herausschleifen.
Das Teil mit Schleifpaste (z.B. **STANDOX**)
Polieren von Hand oder mit einer Poliermaschine
Von Hand mit Glanzpolitur (z.B **STANDOX Lackpolish Siliconfrei**)
Polieren von Hand oder mit Poliermaschine.

ACHTUNG HERSTELLERHINWEISE BEACHTEN !!!

GB

Painting Instruction !!!

- 1) **Sanding:** Sand with Scotchbrite
- 2) **Cleaning:** Clean with silicone remover (e.g **Toyota Hydro Cleaner PZ469-A0002-50**)
Wipe part with dustbonding cloth (e.g. **Fa. BERNER Art. No. 85910.1**)
- 3) **Base coating :**
e.g **Toyota Hydro Base coat, ...**
- 4) **Clear coating:**
e.g. **Toyota 2K HS Clear PZ469-C0002-50, ...**
- 5) **Drying:**
- At max 40 °C for at least 1 hour or let it dry overnight at room temperature (dust dry)
Storage at for at least 24 hours at room temperature (thoroughly hardened)
- 6) **Polishing:**
Sand visible dust enclosures with sand paper (e.g. **Fa. 3M 13444**)
Rub part with polish paste (e.g **STANDOX**)
Polish with shinypolish by hand and high polish with a clean polishing cloth
(e.g **STANDOX Paintpolish w/o silicone**)

FOLLOW INSTRUCTIONS OF PAINT SUPPLIER !!!

F

Conseils Pour La Peinture !!!

- 1) **Ponçage:** poncer la pièce avec Scotchbrite
- 2) **Nettoyage:**
Nettoyer avec un dissolvant à silicone (ex. : **Toyota Hydro Cleaner PZ469-A0002-50**)
Essuyer la pièce avec un chiffon antipoussière (ex. **Fa. BERNER Art. 85910.1**)
- 3) **Peinture finale en utilisant:**
ex. : Toyota Hydro Base coat (peinture de base) , ...
- 4) **Vernis Transparent :**
ex.: Toyota 2K HS Clear PZ469-C0002-50, ...
- 5) **Séchage:**
- A max. 40°C min. pendant une heure ou une pose à température ambiante pendant la nuit
(hors poussière) Entreposage de 24 heures minimum à température ambiante (entièrement durci).
- 6) **Polissage:**
Polir des impuretés visibles avec du papier-émeri (ex. **Fa. 3M 13444**).
Enduire la pièce de pâte abrasive
(**ex : STANDOX**)
et polir manuellement ou à la machine.
Polir à la main avec un vernis brillant (**STANDOX Paintpolish w/o silicone**)
Polir manuellement ou à la machine.

ATTENTION! RESPECTER LES CONSEILS DU FABRICANT !!!

NL

Aanwijzingen voor het lakken !!!

- 1) **Schuren:** Schuren van de onderdelen met Scotchbrite
- 2) **Reiniging:**
Reinigen met siliconenverwijderaar **Toyota Hydro Cleaner PZ469-A0002-50**
schoonvegen van het onderdeel met een stofbindende doek (**bijv. firma BERNER Art. 85910.1**)
- 3) **Deklaag met gebruik van:**
bijv. Toyota Hydro Base coat, ...
- 4) **Klaarlak met gebruik van:**
bijv. Toyota 2K HS Clear PZ469-C0002-50, ...
- 5) **Droging:**
Op max. 40°C gedurende min. 1 uur of opslag bij kamertemperatuur gedurende een nacht
(stofdroog) Opslag gedurende min. 24 uren op kamertemperatuur (volkomen uitgehard)
- 6) **Polijsen:**
Zichtbare stofafzettingen met schuurvellen (**bijv. firma 3M 13444**) uitschuren.
Het onderdeel met schuurpasta (**bijv. STANDOX**)
polijsten met de hand of met een polijstmachine
Met de hand met glansmiddel (**bijv. STANDOX Standohyd Lackpolish Siliconvrij**) polijsten
of met polijstmachine.

OPGELET AANWIJZINGEN VAN DE FABRIKANT IN ACHT NEMEN!!!