

TOYOTA

AVENSIS

T 25 / Wagon

General Type Approval: KBA 39042

Part Number: PZ 439-T9471-AB

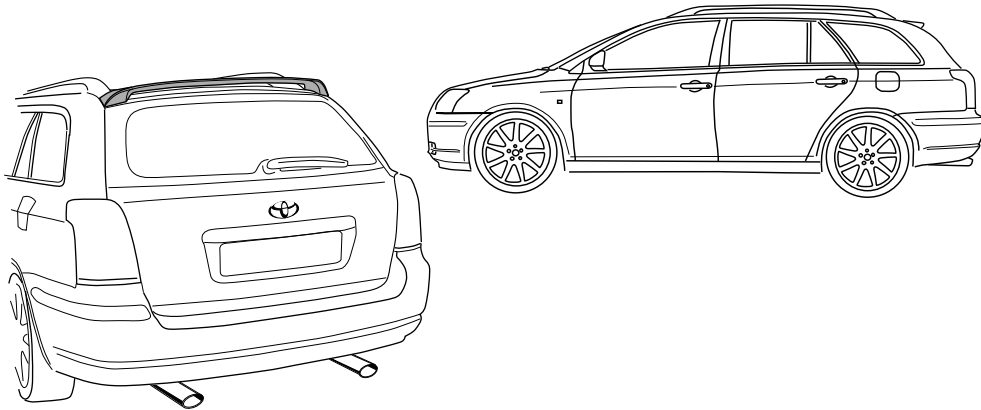

Roof Spoiler
Dach Spoiler
Bequet de Toit
Dakspoiler

KIT CONTENT - STÜCKLISTE - CONTENU - KIT INHOUD

Fixing Kit - AM 18 112

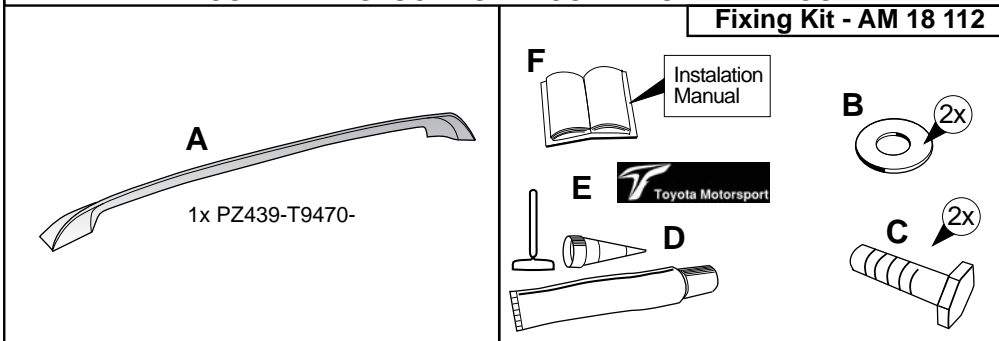

Weight: 1,3 kg
Installation time: 30 minutes

Gewicht: 1,3 kg
Anbauzeit: 30 minuten

Poids: 1,3 kg
Temps d'installation: 30 minutes

Gewicht: 1,3 kg
Istallatie tijd: 30 minuten

INSTALLATION MANUAL - ANBAU ANLEITUNG - MONTAGE HANDLEIDING - MANUEL D'INSTALLATION

PZ 439-T9471-AB

AM 18 110

PAGE: 1/8

Date: 01/07

PART NAME: ROOF SPOILER

Part Number: PZ 439-T9471-AB

APPLICATION / ANWENDUNG / APPLICATE



MODEL CODE: **T25**-AW***W

1







VEHICLE OPTION / FAHRZEUG OPTION / OPTION VEHICULE / VOERTUIG OPTIE

ACCESSORY / ZUBEHÖR / ACCESSOIRE

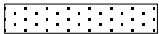
	Step/Punkt/Point/Stap		Step/Punkt/Point/Stap
	Step/Punkt/Point/Stap 10		Step/Punkt/Point/Stap

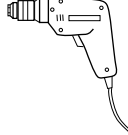
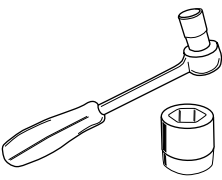
TOOLS / WERKZEUG / OUTILS / WERKTUIGEN

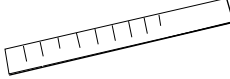
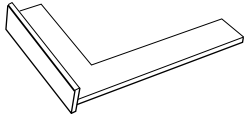
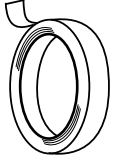
 Sandpaper Schleifpapier Papier de verre Schuurpapier	 3 mm, 10 mm Bits 3 mm, 10 mm Bohrer 3 mm, 10 mm Forets 3 mm, 10 mm Boor	 Drill Bohrmaschine Perceuse Boormachine
 # 10	 Cleaner Entfetter Dégraisseur Envetter	
	 Adhesive tape Klebeband Ruban adhésif Kleefband	

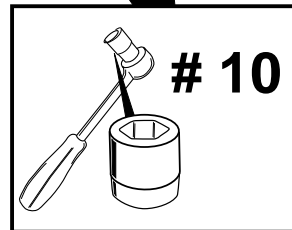
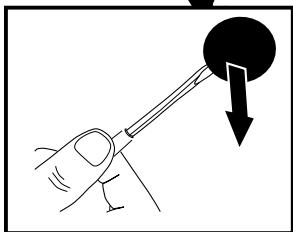
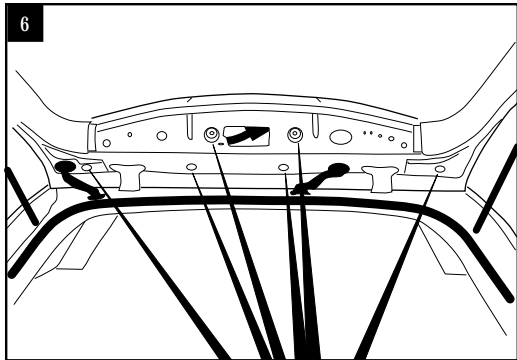
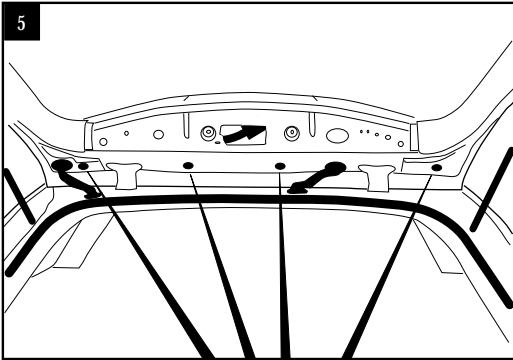
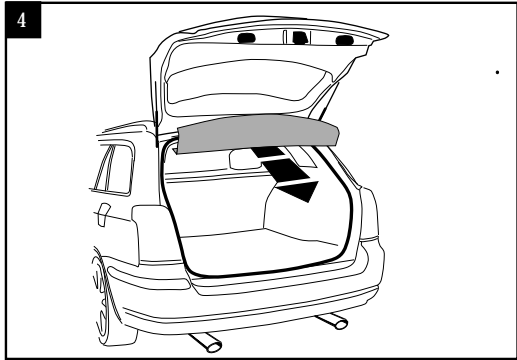
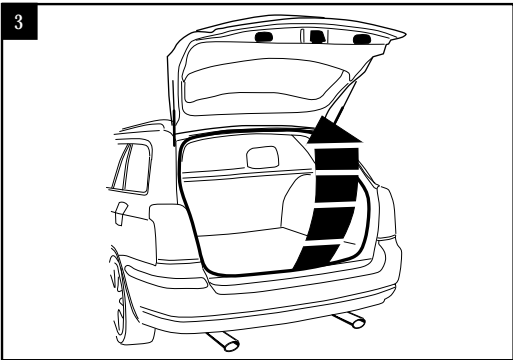
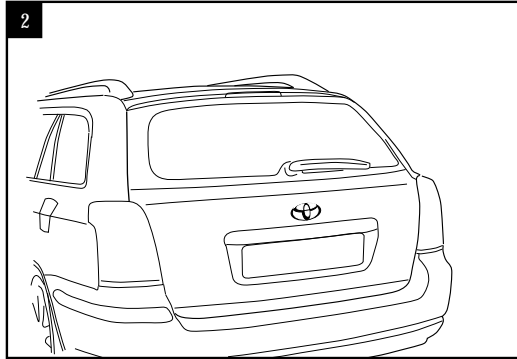
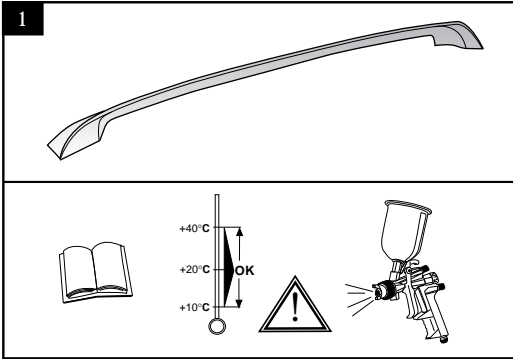

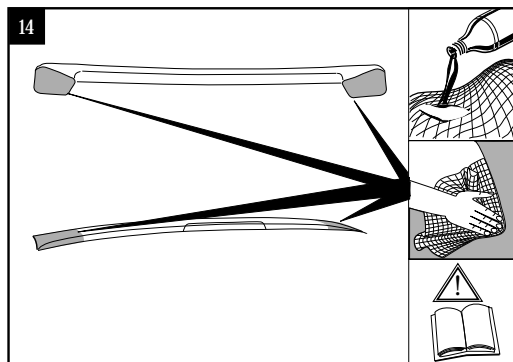
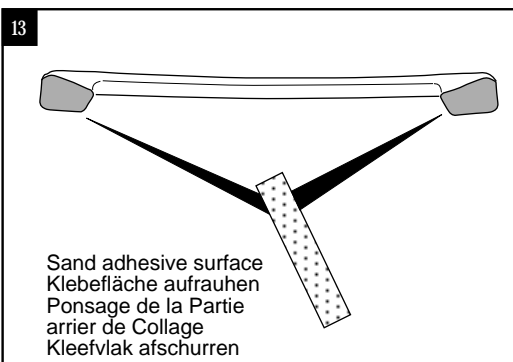
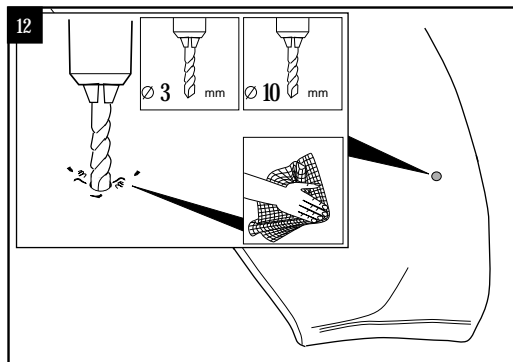
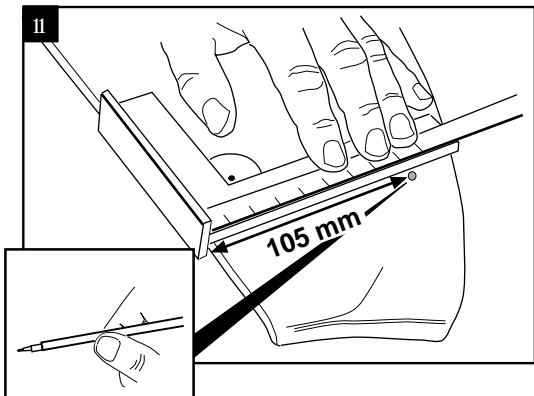
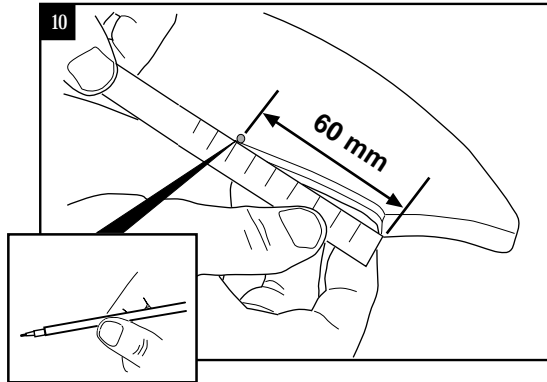
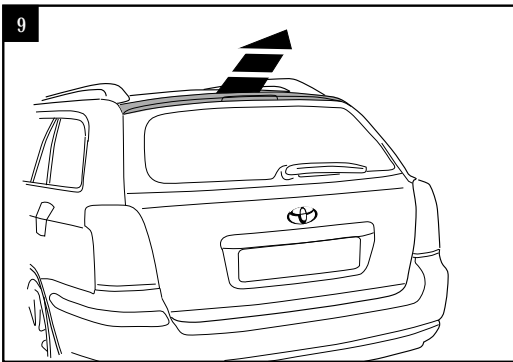
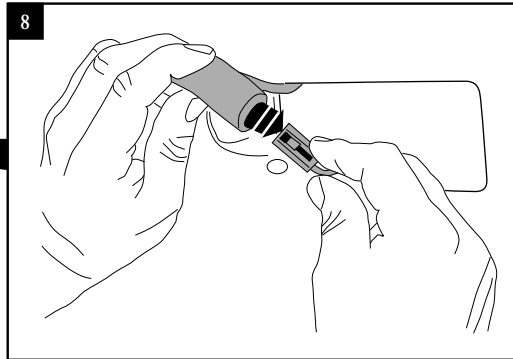
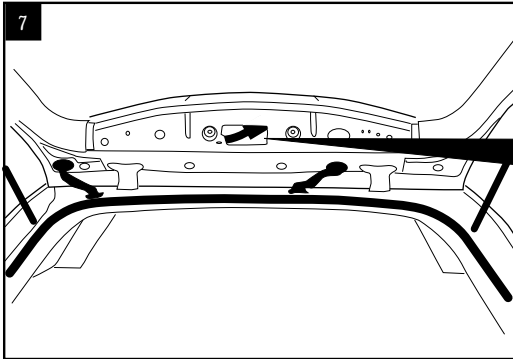

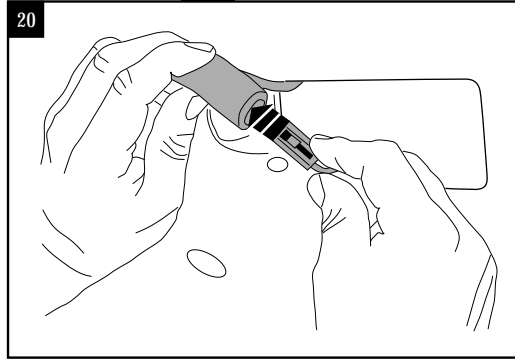
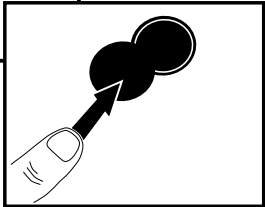
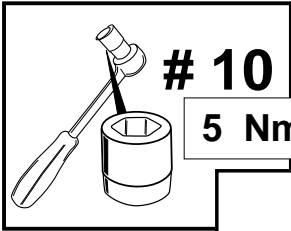
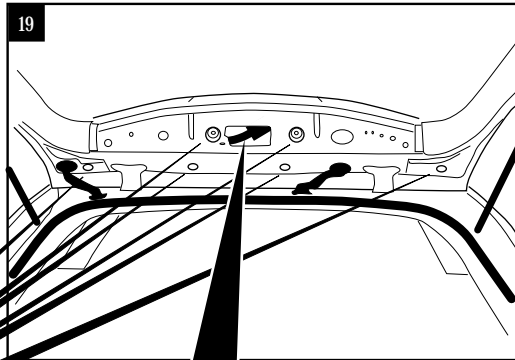
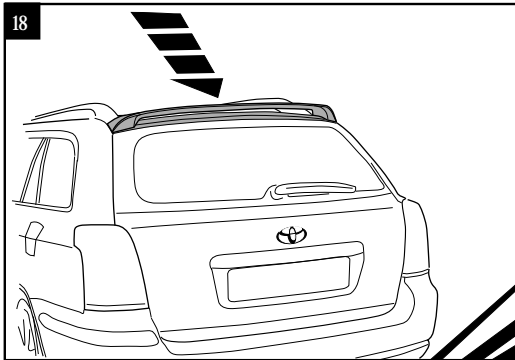
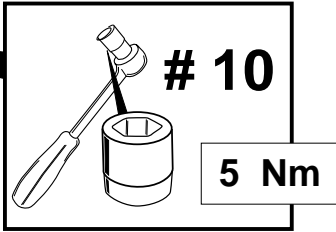
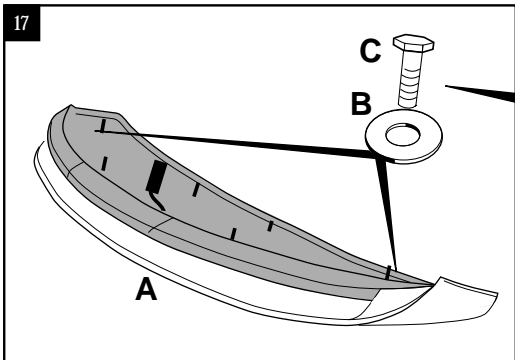
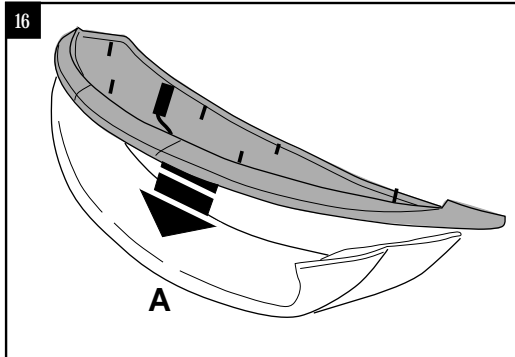
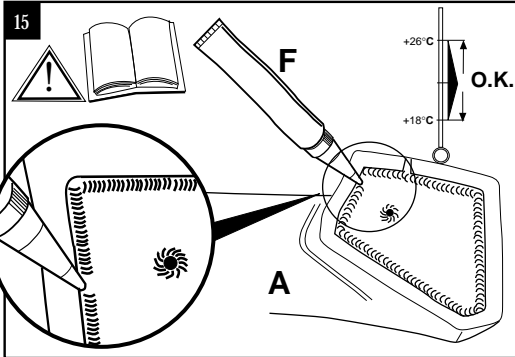

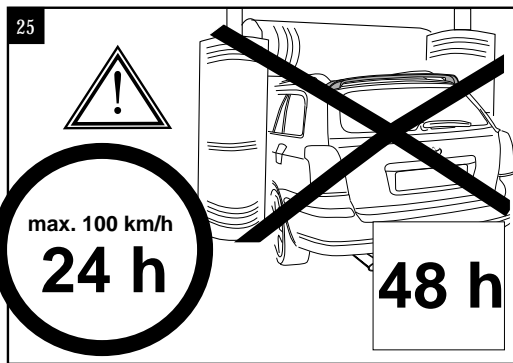
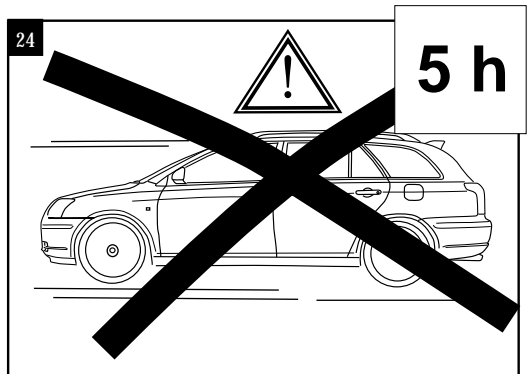
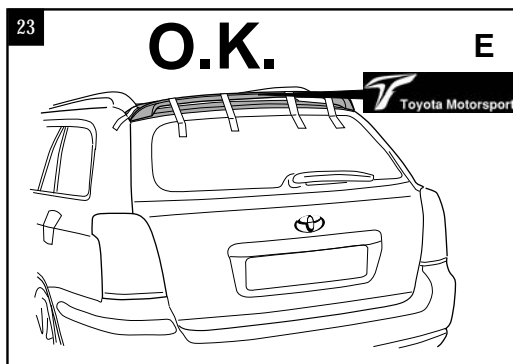
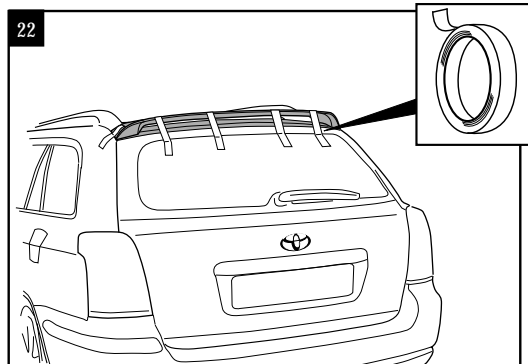
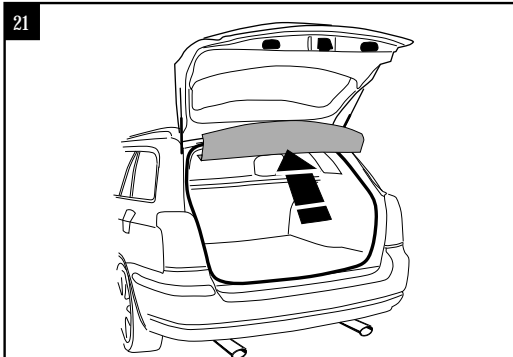

Painting Instruction !!!

- 1) The part is already primed ! (Not base coat ready !!!)
- 2) Sanding: Sand part with P 1000 water-sandpaper and putty if pores are visible (e.g. STANDOX : Standosoft - Feinplastic)
Should the primer layer come off during sanding primer must be applied again.
(e.g STANDOX : Standoflex 1K PUR Primer – Filler)
- 3) Pore Filler: If micro pores or scratches are visible use pore -filler
(e.g STANDOX Standoflex Pore-Filler)
- 4) Cleaning:
 - Clean with silicone remover (e.g STANDOX : Silicon Remover TB 10)
 - Wipe part with dustbonding cloth (e.g. Fa. BERNER Art. No. 85910.1)
- 5) Base coating :
e.g STANDOX Base coat
e.g STANDOX 2K Plasticiser
- 6) Clear coating:
e.g. Standocryl 2K Clear
- 7) Drying:
 - At max 40 °C for at least 1 hour or let it dry overnight at room temperature (dust dry)
 - Storage at for at least 24 hours at room temperature (thoroughly hardened)
- 8) Polshing:
Sand visible dust enclosures with sand paper (e.g. Fa. 3M 13444)
Rub part with polish paste (e.g STANDOX : Standohyd abrasive and polishpaste)
Polish with shinarypolish by hand and high polish with a clean polishing cloth
(e.g STANDOX Paintpolish w/o silicone)

FOLLOW INSTRUCTIONS OF PAINT SUPPLIER !!!

Rev.1: 23.11.01

Hinweise zur Lackierung !!!

- 1) Das Teil ist schon grundiert !!! (Nicht Basislackfertig !!!)
- 2) Schleifen: Schleifen der Teile mit P 1000 Wasserschleifpapier und wenn Poren sichtbar sind kitten (z.B. STANDOX : Standosoft - Feinplastic)
Wird beim Vorbereiten zum Lackieren die Grundierschicht durchgeschliffen, so ist nochmals zu grundieren (z.B. STANDOX : Standoflex 1K PUR Primer – Filler)
- 3) Füllern : (z.B. STANDOX Standoflex Porenfüller)
- 4) Reinigung:
 - Reinigen mit Silikonentferner (z.B. STANDOX : Silicon Entferner TB 10)
 - Abwischen des Teiles mit einem Staubbindetuch (z.B. Fa. BERNER Art. 85910.1)
- 5) Decklackierung unter Verwendung von :
z.B. STANDOX Basislack
z.B STANDOX 2K Elastic-Additiv
- 6) Klarlackierung unter Verwendung von :
z.B. Standocryl 2K Clear
- 7) Trocknung:
 - Bei max. 40°C für mind. 1 Std. oder Lagerung bei Raumtemperatur über Nacht (Staubtrocken)
 - Lagerung für mind. 24 Std. bei Raumtemperatur (vollkommen ausgehärtet)
- 8) Polieren:
Sichtbare Staubeinschlüsse mit Schleifblüten (z.B. Fa. 3M 13444) herausschleifen.
Das Teil mit Schleifpaste (z.B. STANDOX : Standohyd Schleif u. Polierpaste)
Polieren von Hand oder mit einer Poliermaschine
Von Hand mit Glanzpolitur (z.B STANDOX Lackpolish Siliconfrei)
Polieren von Hand oder mit Poliermaschine.

ACHTUNG HERSTELLERHINWEISE BEACHTEN !!!

Rev.1: 23.11.01

Conseils Pour La Peinture !!!

- 1) La pièce a déjà reçu une couche de fond !!! (Non finit pour la couche de base !!!)
- 2) Ponçage: poncer la pièce avec du papier-émeri P 1000 et mastiquer si des pores sont apparents (ex. : STANDOX : Standosoft – Feinplastic)
Si en ponçant vous avez éliminé une partie de la couche de fond, il y a lieu d'appliquer une nouvelle sous-couche (ex. : STANDOX : Standoflex 1K PUR Primer – Filler)
- 3) Remplissage des pores: (ex. : STANDOX Standoflex Pore-Filler)
- 4) Nettoyage:
 - Nettoyer avec un dissolvant à silicone (ex. : STANDOX : Silicon Remover TB 10)
 - Essuyer la pièce avec un chiffon antipoussière (ex. Fa. BERNER Art. 85910.1)
- 5) Peinture finale en utilisant:
ex. : STANDOX Base coat (peinture de base)
ex. : STANDOX 2K Plasticiser
- 6) Vernis Transparent :
ex.: Standocryl 2K Clear
- 7) Séchage:
 - A max. 40°C min. pendant une heure ou une pose à température ambiante pendant la nuit
(hors poussière)
 - Entreposage de 24 heures minimum à température ambiante (entièrement durci).
- 8) Polissage:
Polir des impuretés visibles avec du papier-émeri (ex. Fa. 3M 13444).
Enduire la pièce de pâte abrasive (ex : STANDOX Standohyd abrasive and polishpaste – pâte à papier et polir) et polir manuellement ou à la machine.
Polir à la main avec un vernis brillant (STANDOX Paintpolish w/o silicone)
Polir manuellement ou à la machine.

ATTENTION! RESPECTER LES CONSEILS DU FABRICANT

Aanwijzingen voor het lakken !!!

- 1) Het onderdeel heeft reeds een grondlaag !!! (Niet klaar voor basislak!!!)
- 2) Schuren: Schuren van de onderdelen met P 1000 waterschuurpapier en wanneer poriën zichtbaar zijn opvullen (bijv. STANDOX : Standosoft - Feinplastic)
Wordt bij de voorbereiding voor het lakken de grondlaag doorgeschuurd, dan moet nog eens een grondlaag worden aangebracht (bijv STANDOX : Standoflex 1K PUR Primer – Filler)
- 3) Vulstoffen: (bijv. STANDOX Standoflex Pore-Filler)
- 4) Reiniging:
 - Reinigen met siliconenverwijderaar (STANDOX): Silicon Remover TB 10
 - schoonvegen van het onderdeel met een stofbindende doek (bijv. firma BERNER Art. 85910.1)
- 5) Deklaag met gebruik van:
bijv. STANDOX Base coat
bijv. STANDOX 2K Plasticiser
- 6) Klaarlak met gebruik van:
bijv. Standocryl 2K Clear
- 7) Droging:
 - Op max. 40°C gedurende min. 1 uur of opslag bij kamertemperatuur gedurende een nacht (stofdroog)
 - Opslag gedurende min. 24 uren op kamertemperatuur (volkomen uitgehard)
- 8) Polijsten:
Zichtbare stofafzettingen met schuurvellen (bijv. firma 3M 13444) uitschuren.
Het onderdeel met schuurpasta (bijv. STANDOX : Standohyd schuur- en polijstpasta) polijsten met de hand of met een polijstmachine
Met de hand met glansmiddel (bijv. STANDOX Standohyd Lackpolish Siliconvrij) polijsten of met polijstmachine.

OPGELET AANWIJZINGEN VAN DE FABRIKANT IN ACHT NEMEN!!!

Rev.1: 23.11.01