



TOYOTA

Prius

N1 Conversion kit TDK

Installation instructions



Vehicle code: NHW20L - AHEEBW

Part number: PZ449-G3E30-00



Weight: 56 kg

Manual reference number: AIM 001 013- 2

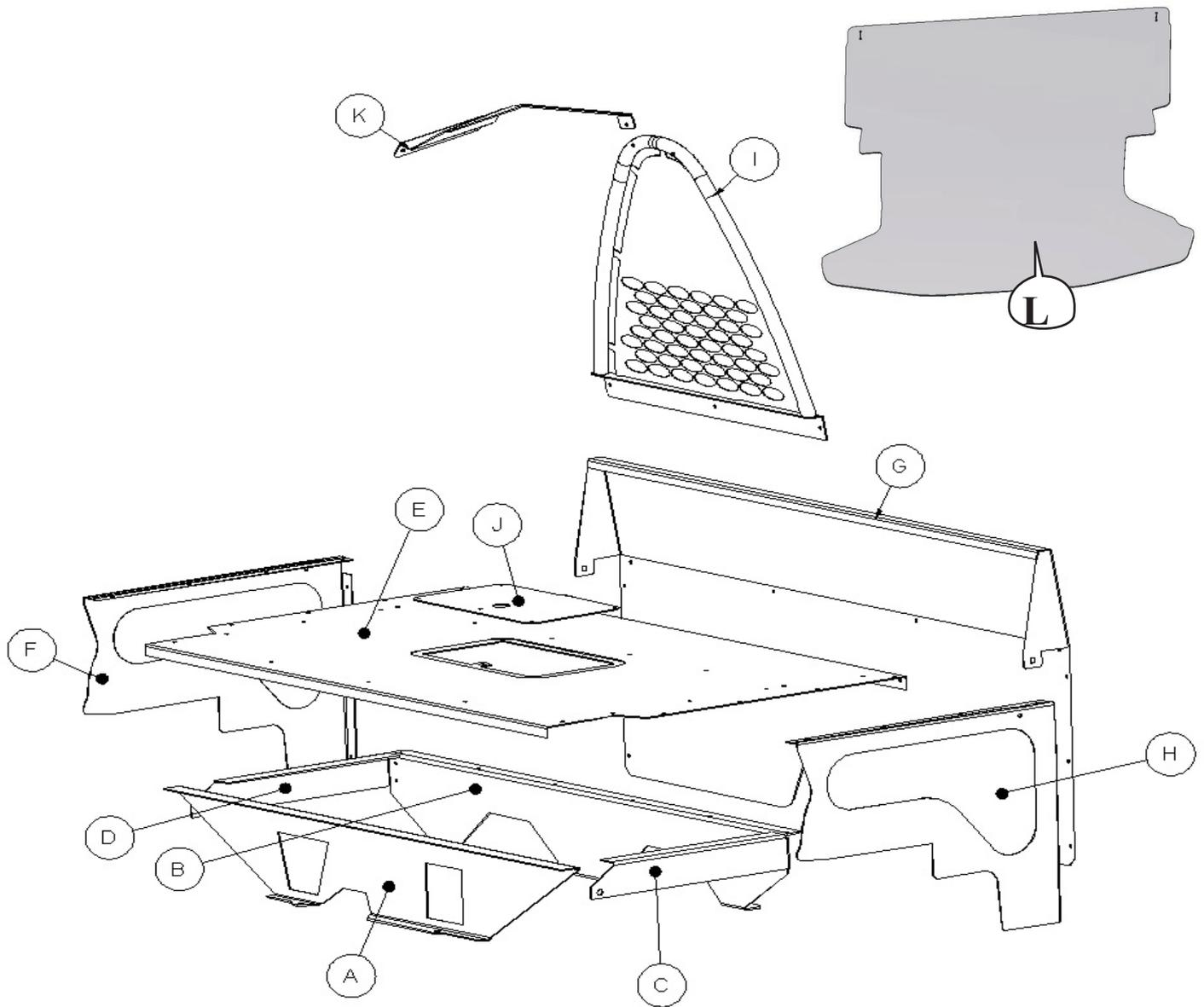

ITEM	QTY	Part number	Description
A	1	15000651	Rear floor support
B	1	15000652	Front floor support
C	1	15000654	Floor support Right
D	1	15000653	Floor support Left
E	1	15000657	Floor
F	1	15000655	Left Floor side cover
H	1	15000656	Right Floor side cover
G	1	15000658	Lower separator
I	1	15000659	Half top separator
J	1	05101205	Hatch 340x210
K	1	15000664	Handle Bracket Left
L	1	15000666	Full Carpet Floor

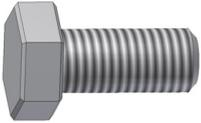
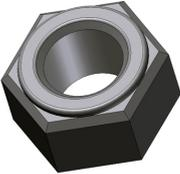
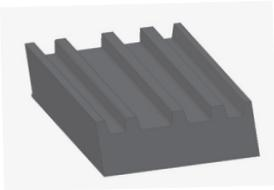
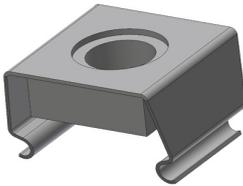
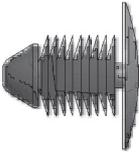
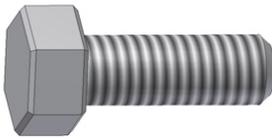
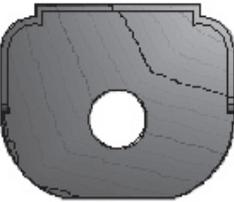
<p>AA 6x16 6K 9 PCS</p> 	<p>BB 6,4x15x1,5 S 18 PCS</p> 	<p>M 05-97062 2PCS</p> 
<p>N 15000668 2PCS</p> 	<p>O 221 M06SW10S 12 PCS</p> 	<p>P 5x14 NSS 39 PCS</p> 
<p>Q MP 8236A M6 2 PCS</p> 	<p>R 6 NMU 6PCS</p> 	<p>S 6x20 6K 2 PCS</p> 
<p>T 36.7210004 4,1 m</p> 	<p>U 123-M06-2C ZC 3PCS</p> 	<p>V M6x20 Ø20 rattskrue 1 PCS</p> 
<p>W 500250 2 PCS</p> 	<p>X FTB 010 2 PCS</p> 	<p>Y 05100878 2 PCS</p> 
<p>Z 6x40 6K 1PCS</p> 	<p>FF 8,4x23x2 2PCS</p> 	<p>GG 8x20 6K 2PCS</p> 
<p>HH 500252 2 PCS</p> 		

1



2

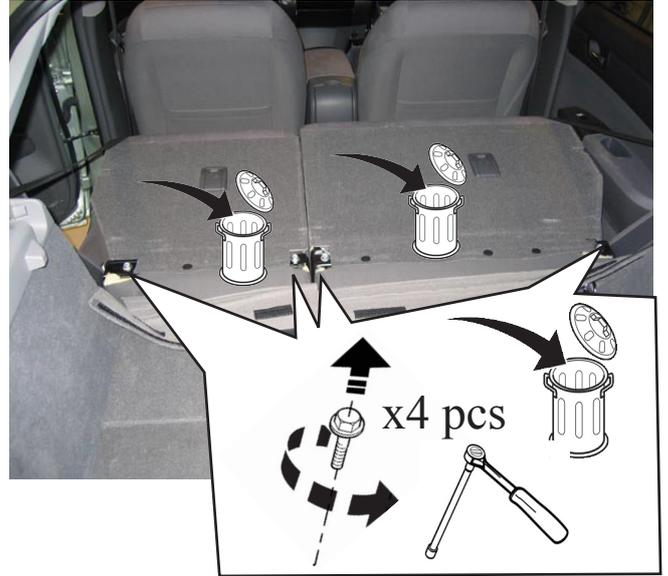

3

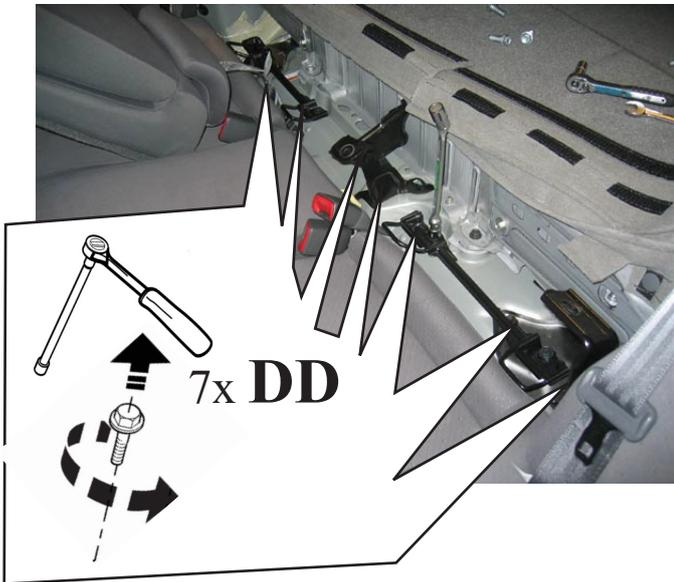

4



5

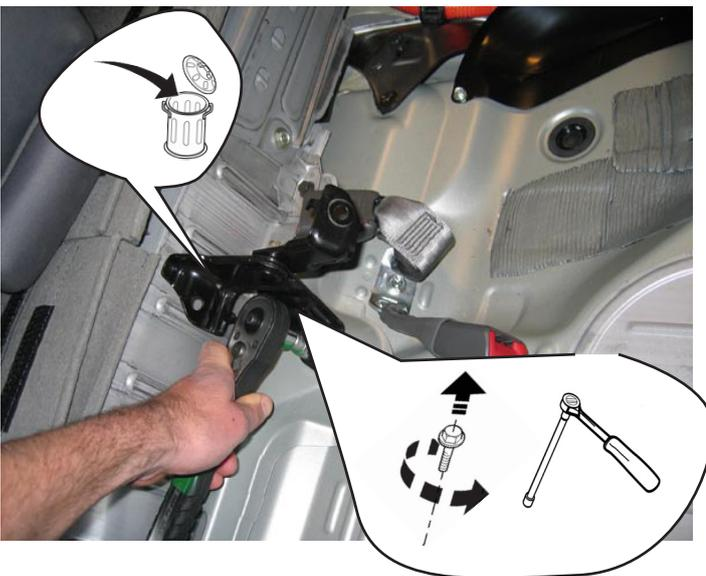

6

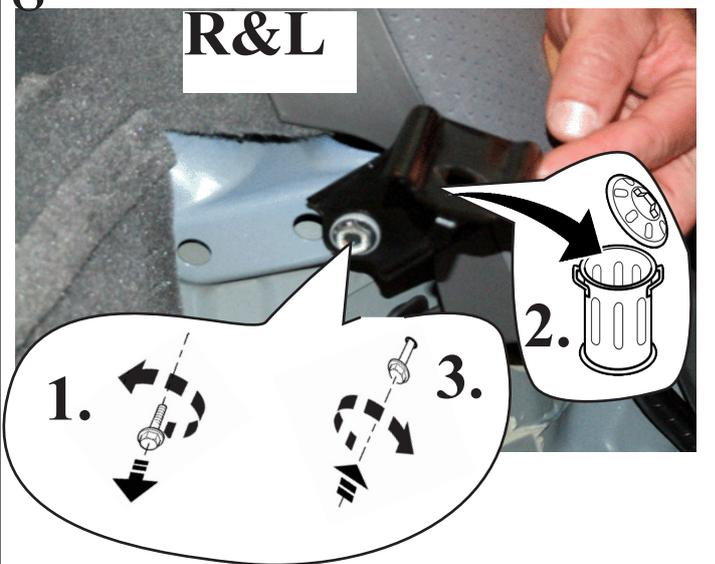

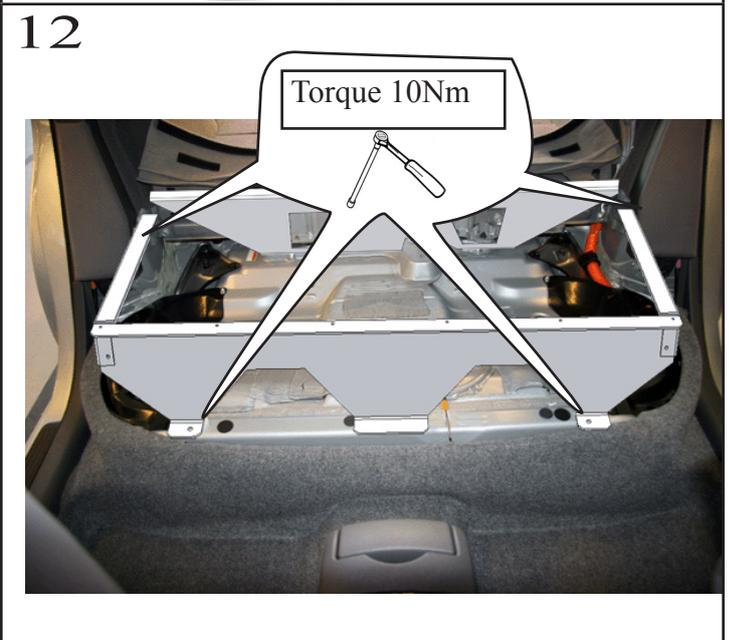
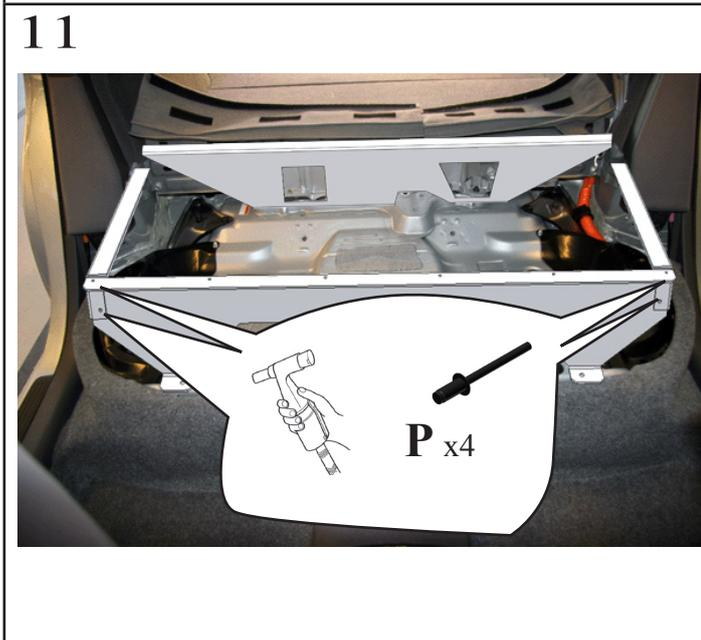
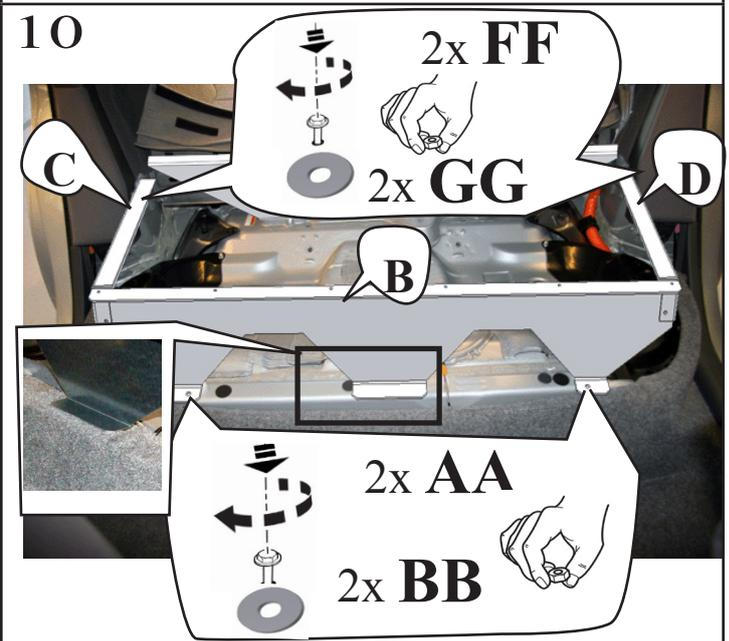
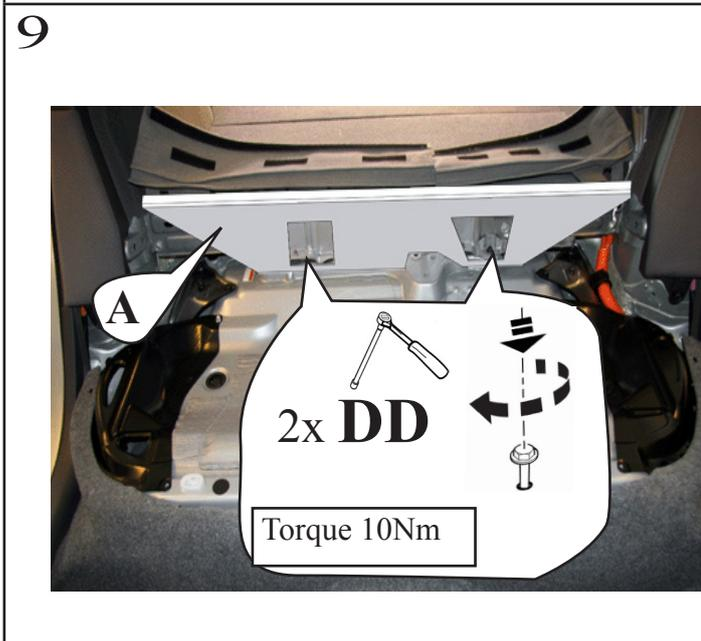
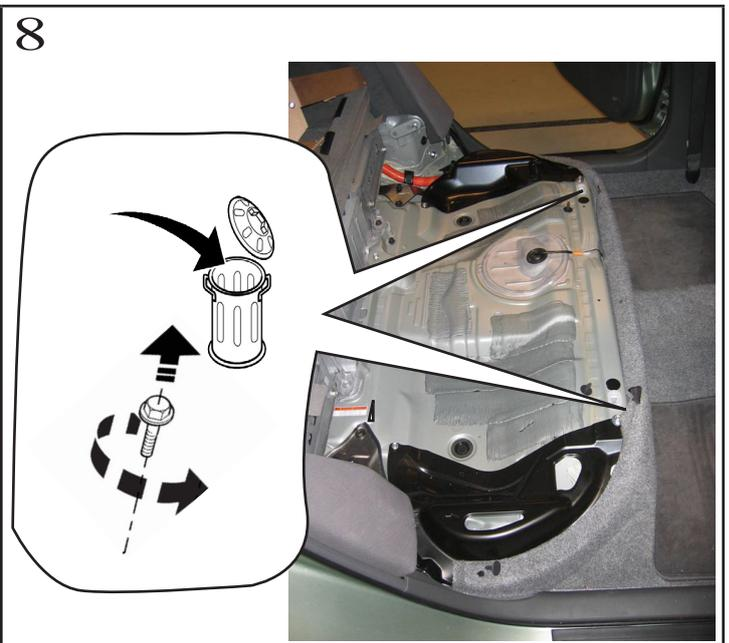
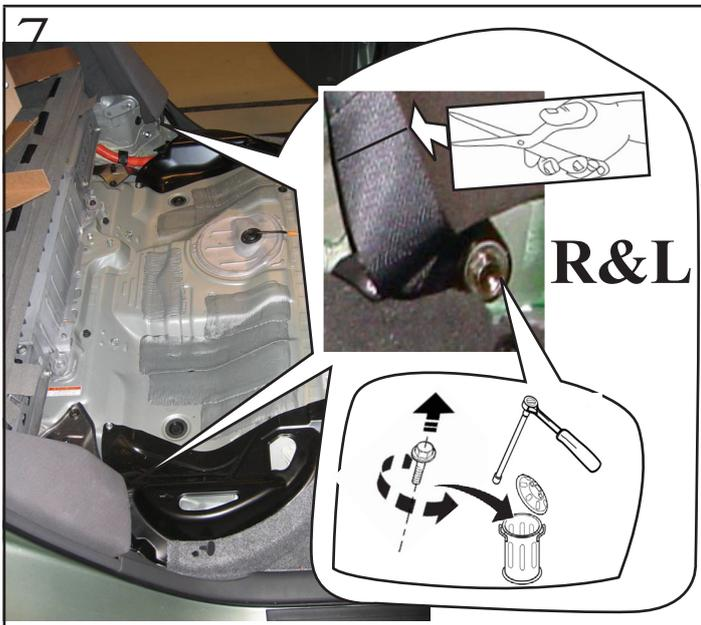

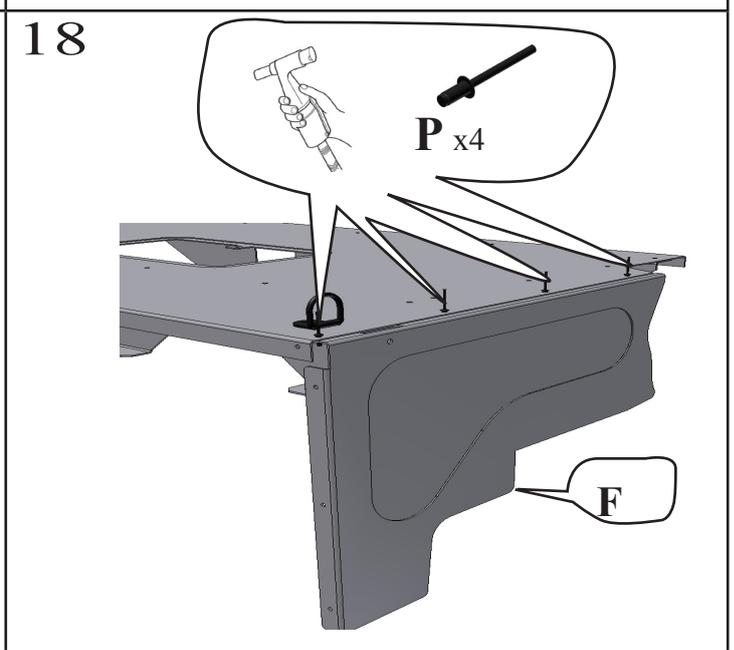
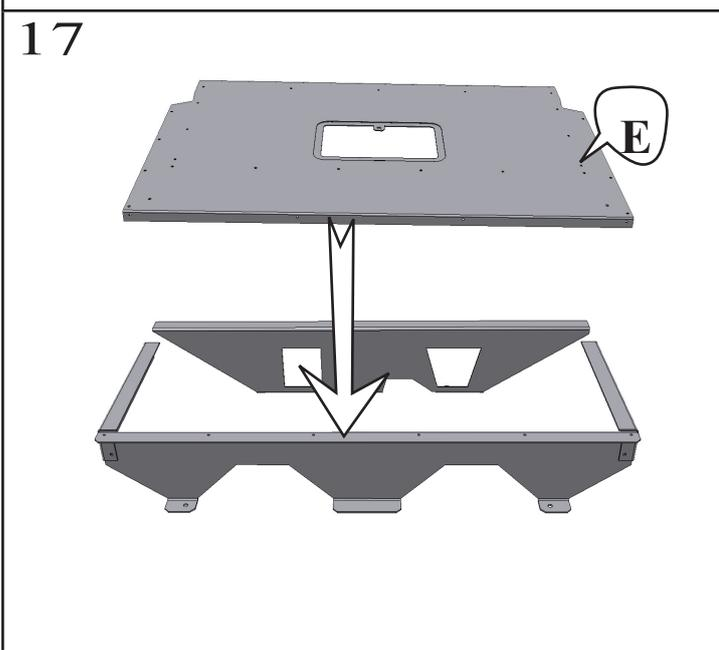
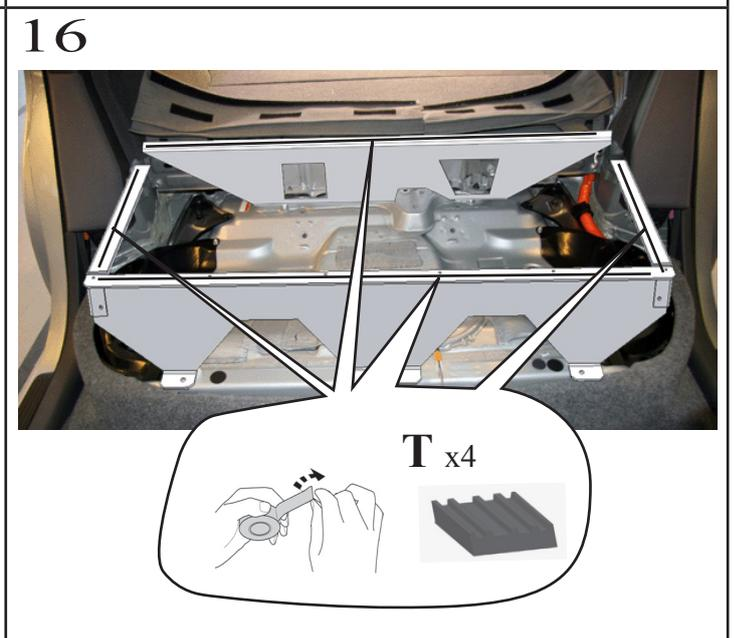
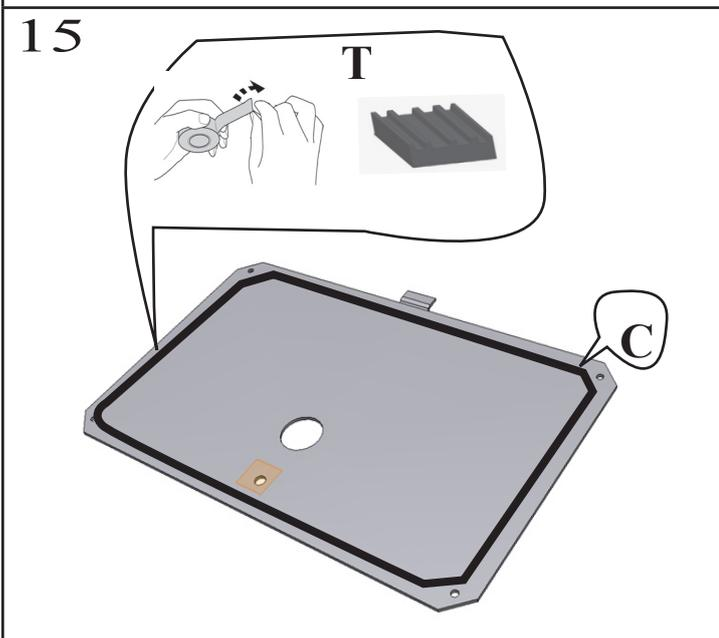
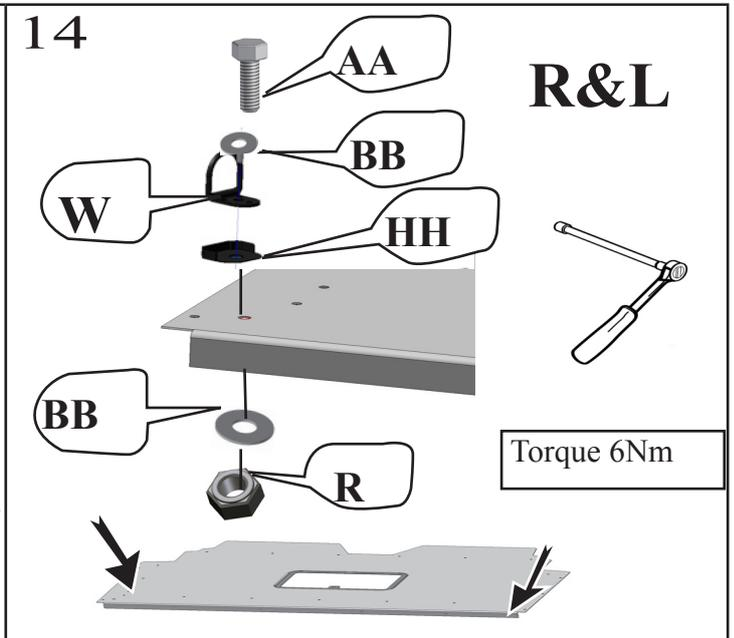
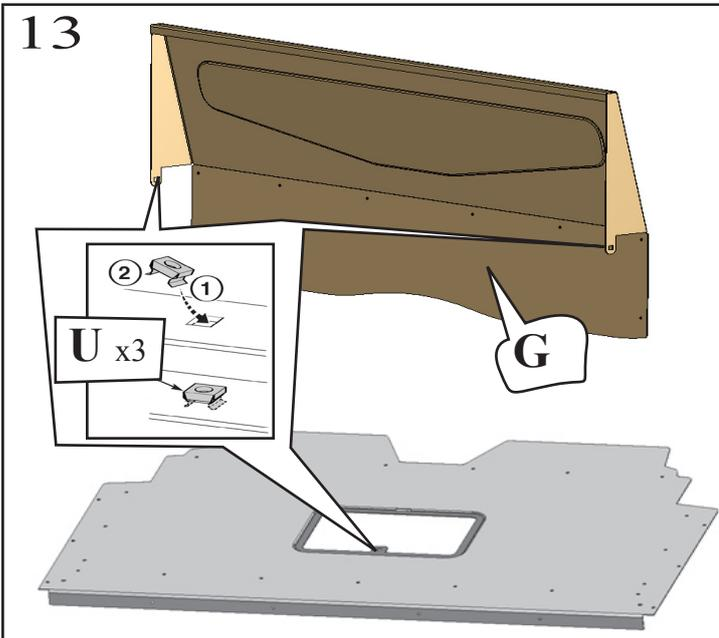

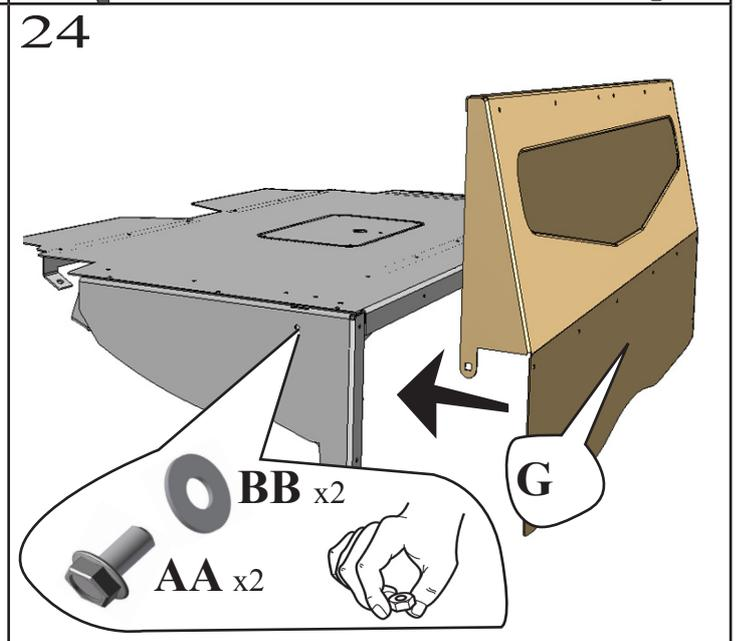
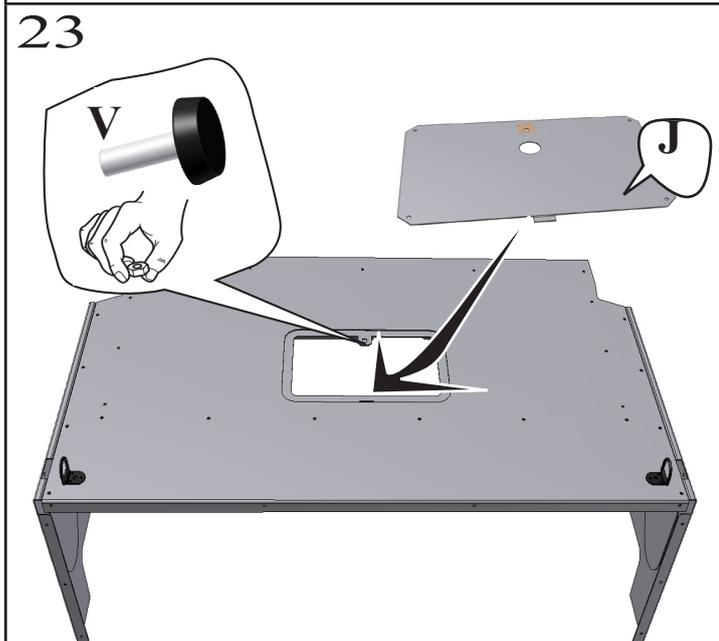
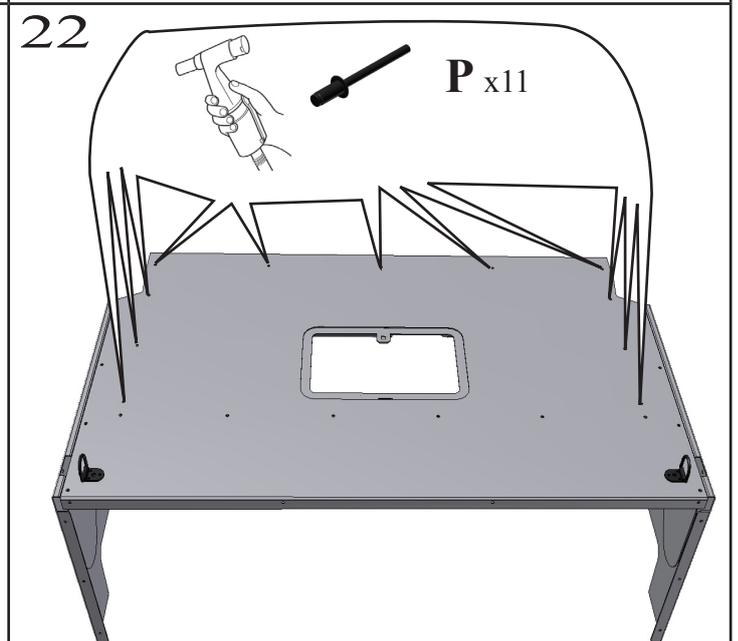
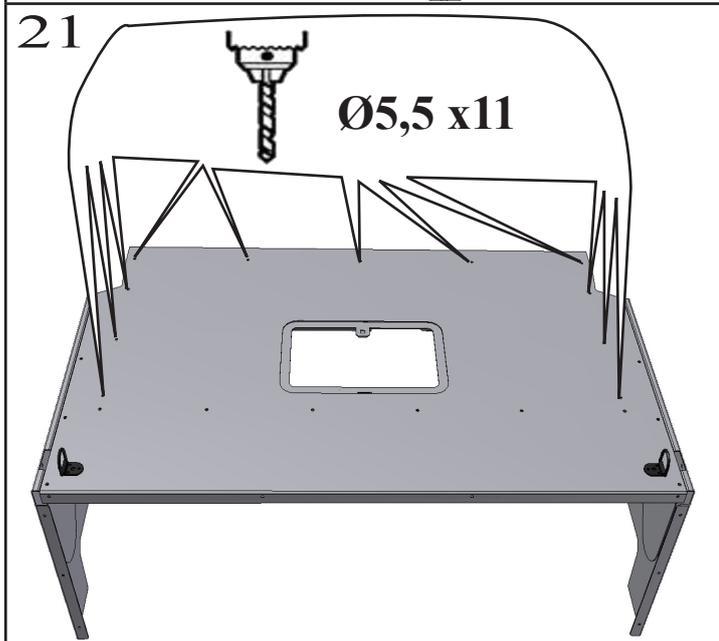
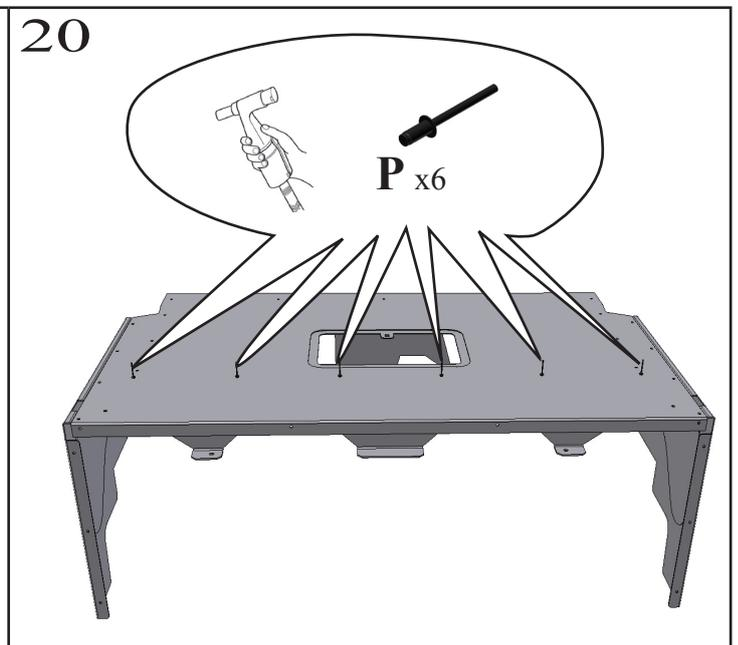
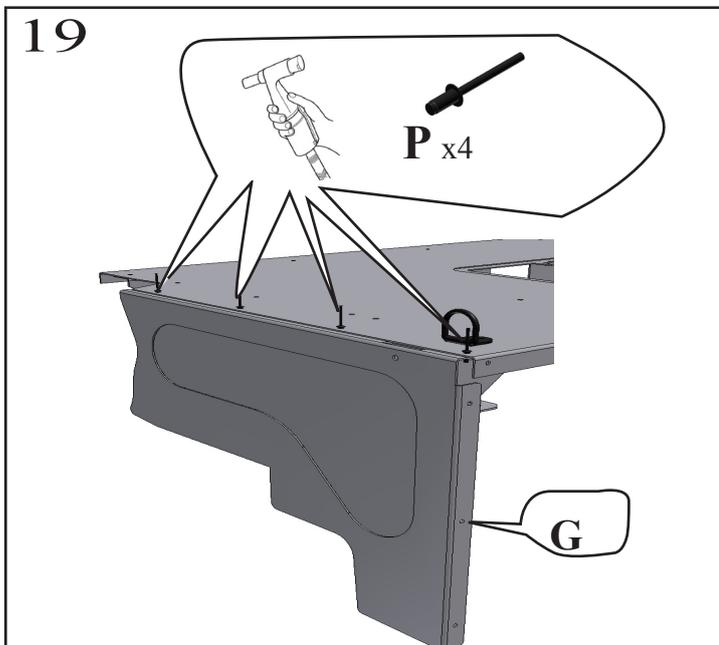

25

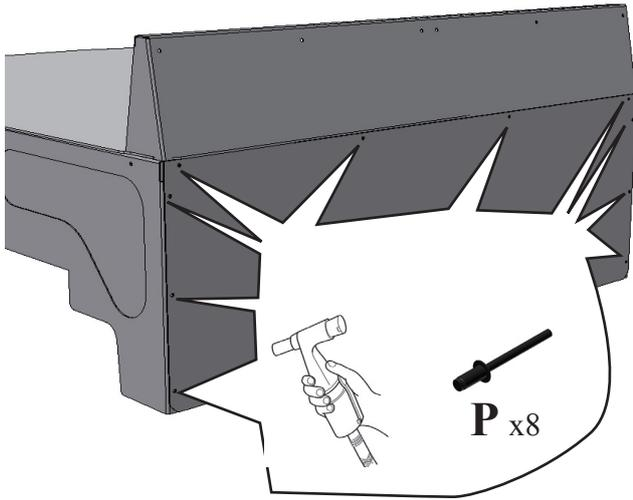

26

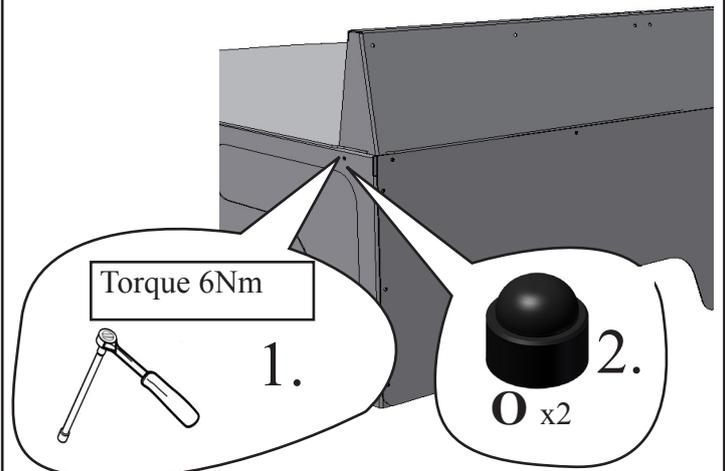

27

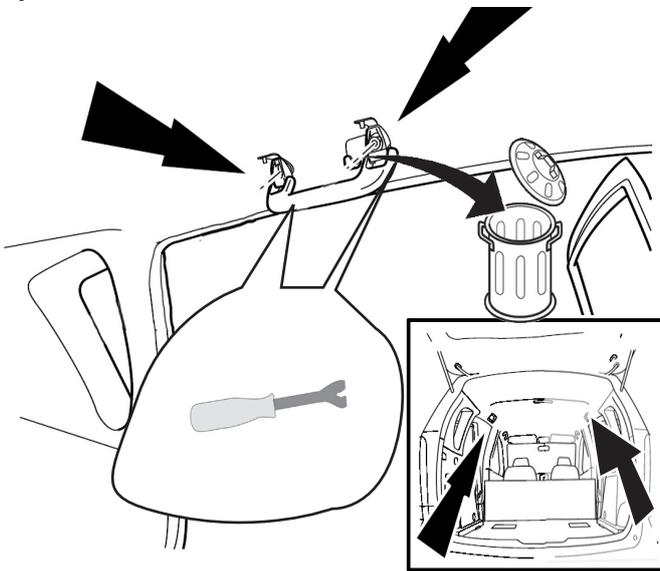

28

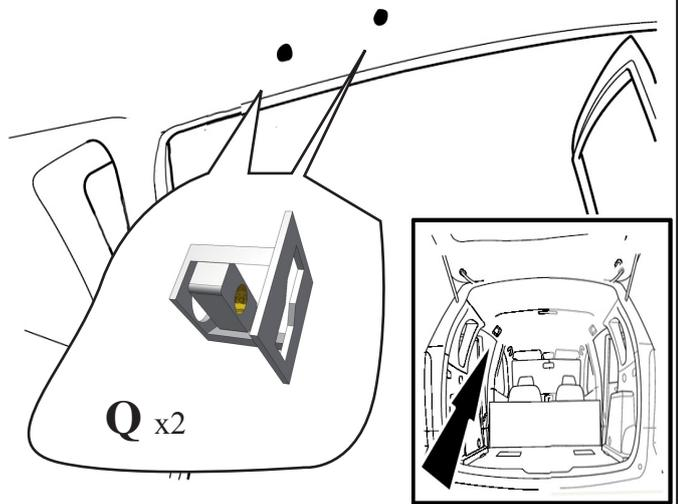

29

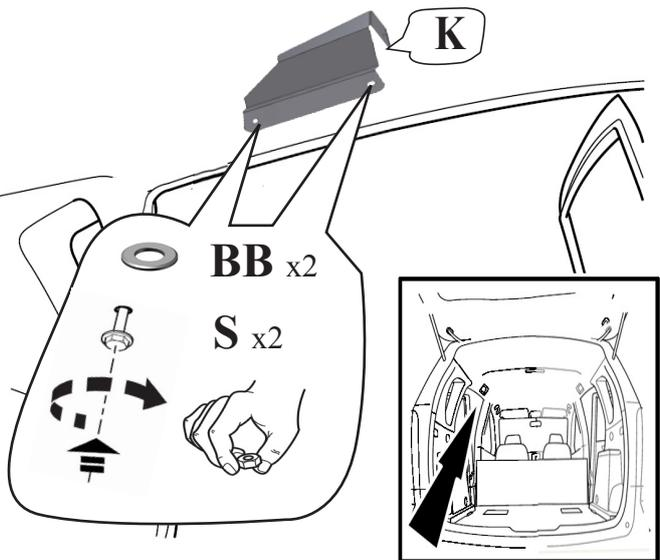

30

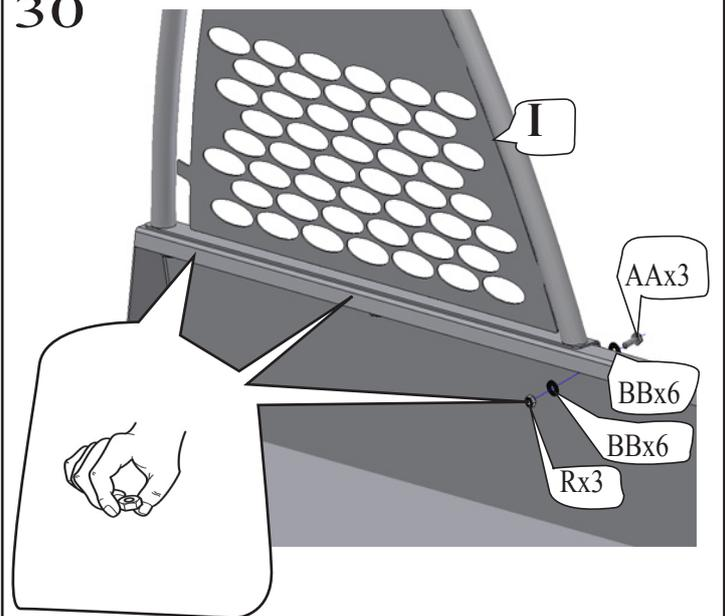

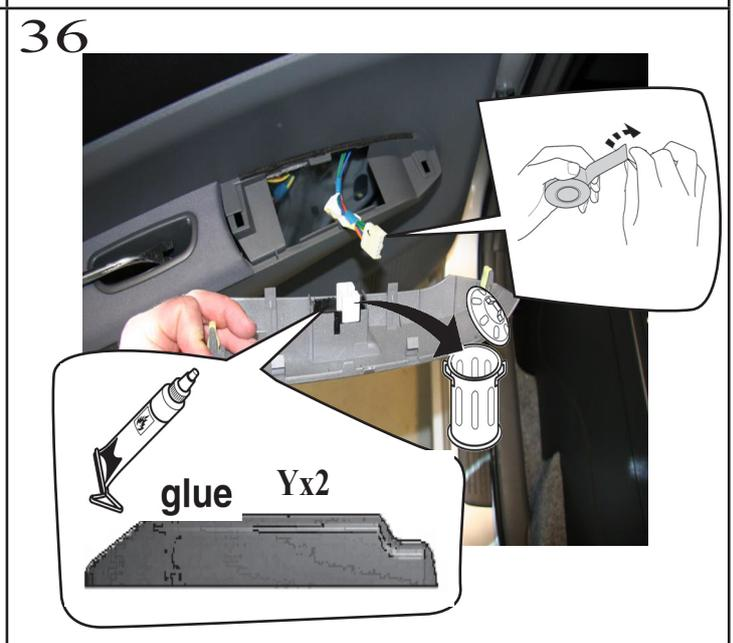
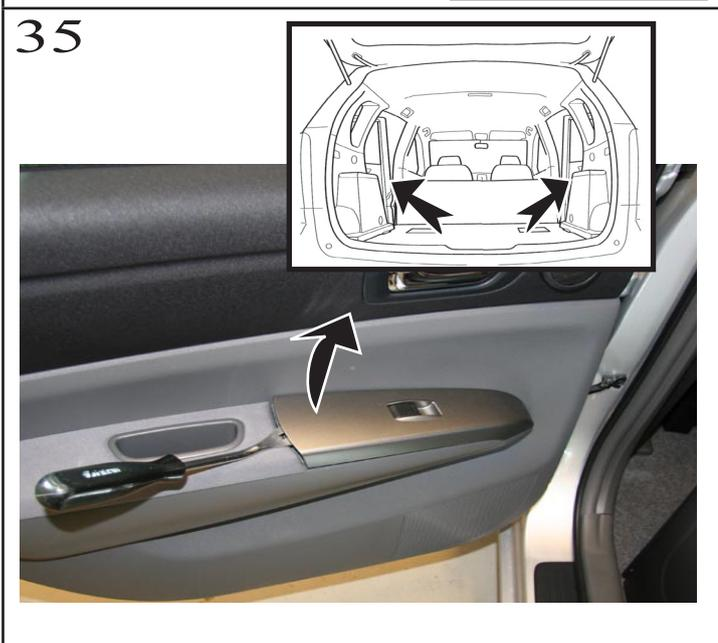
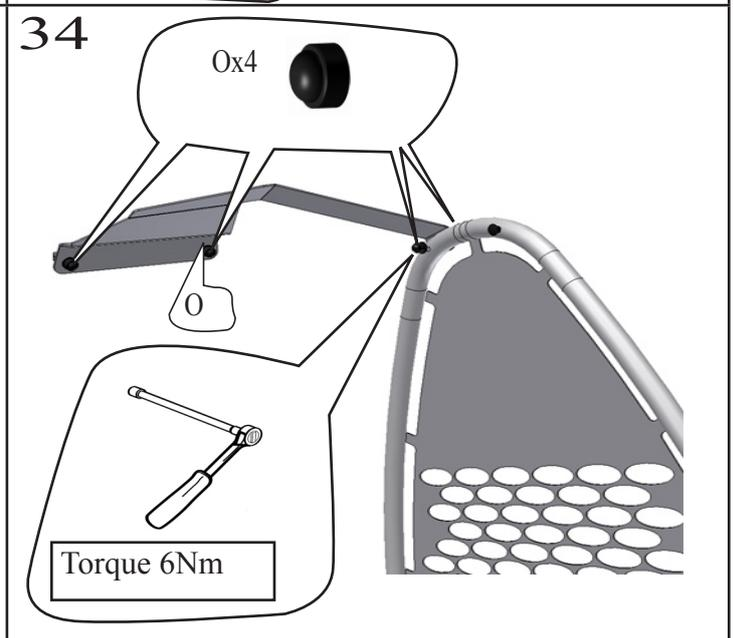
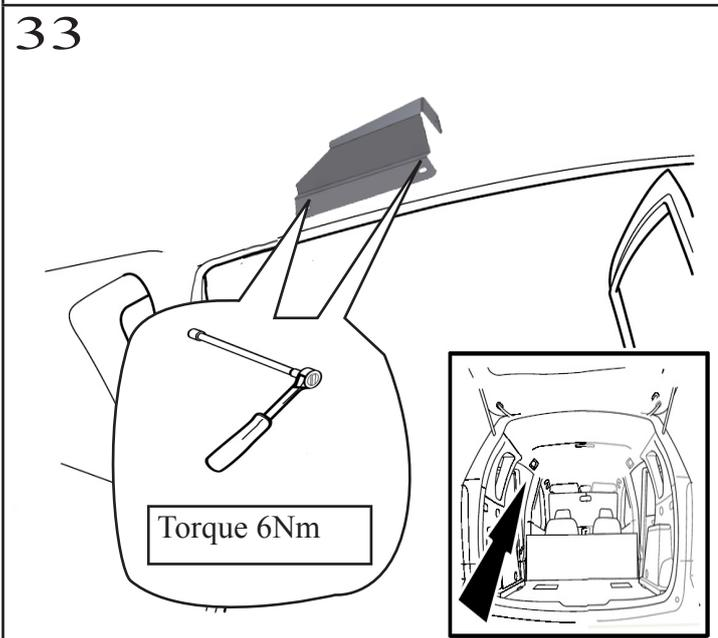
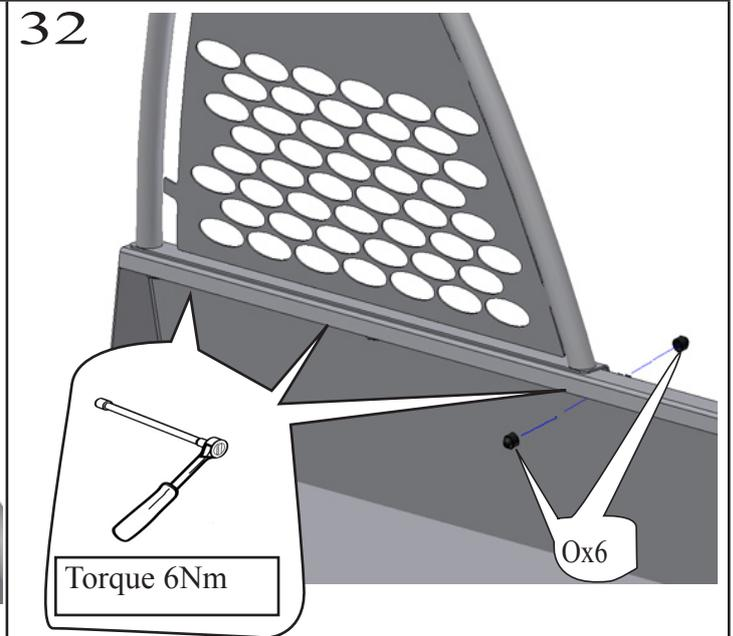
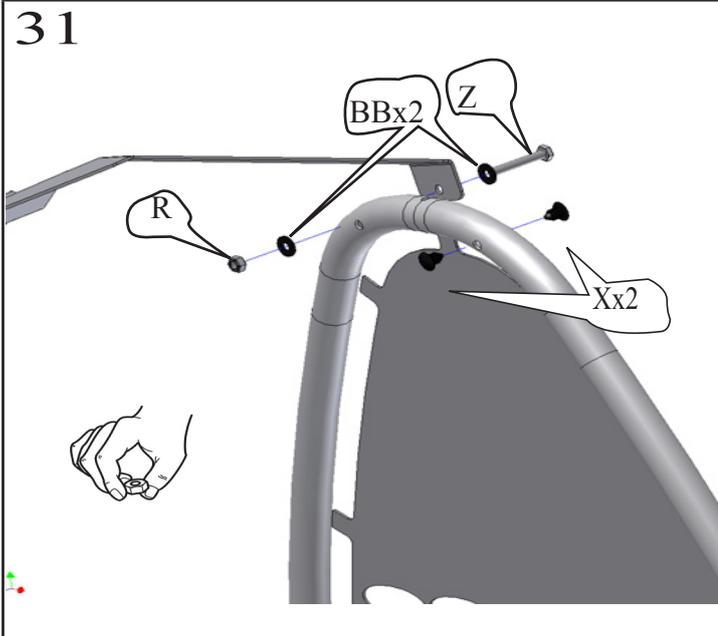

37

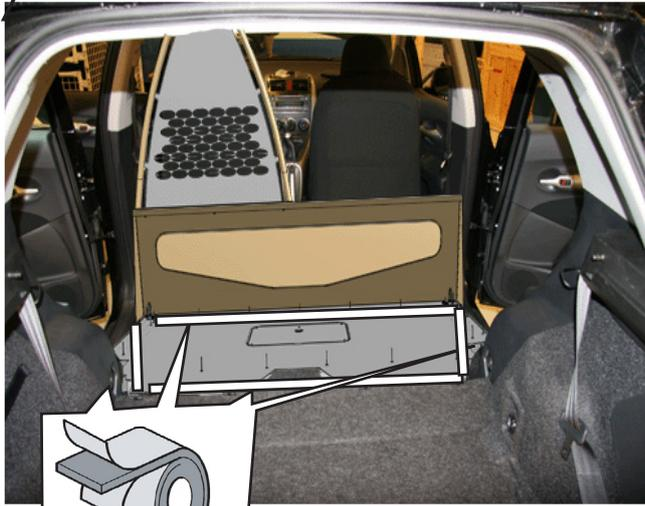

38

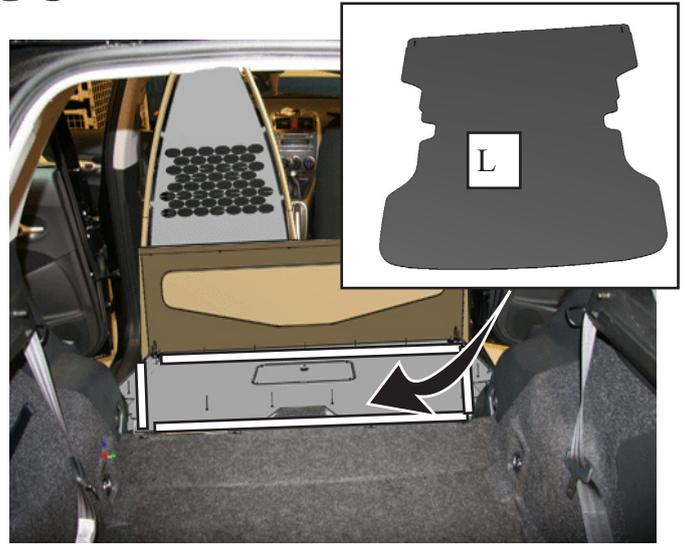

39

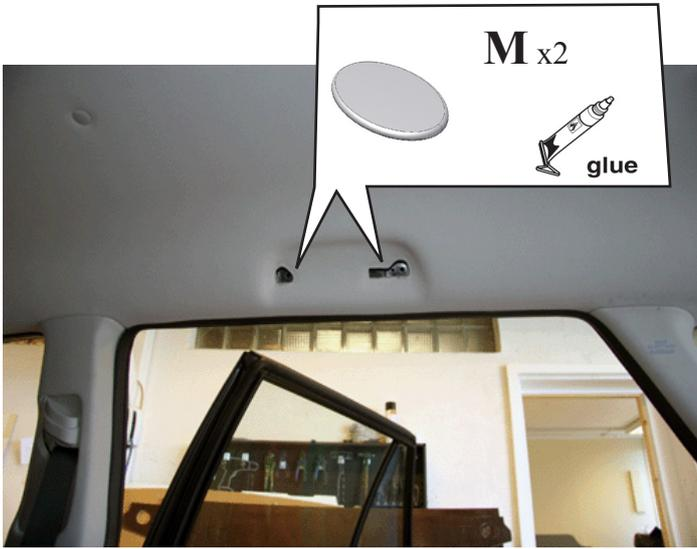

40



41

42