







FRONT UNDERRUN INSTALLATION INSTRUCTIONS RX300/450h

Model year	2008
Vehicle code	G*L15*-AW*GKW
Part number	PZ402-K0950-00

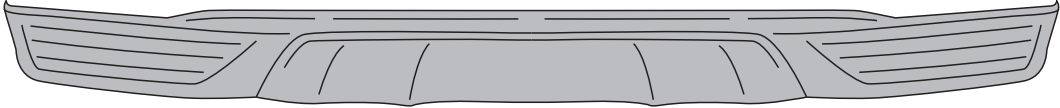
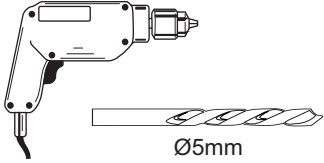
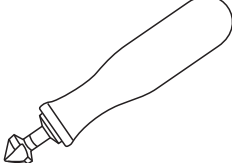
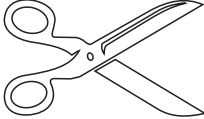
Weight	3.2 kg
--------	--------

Revision Record

Rev. No.	Date	Page	Picture	Update	New	Deleted Steps
1	06/24/09	9	22,23	X	23	X
2	13/06/09			field-fix-kit integrated		
3	20/08/09			title-page		

A					1x
B	C	D	E	F	
G	H	I	J	K	
L	M	N	O	P	
Q					
 <p>Ø5mm</p>					
					
 <p>SW10</p>		 <p>Cleaner</p> <p>SIKKENS M600 Spieß Hecker 7799 Panel degreaser PZ469-CL001-50</p>			

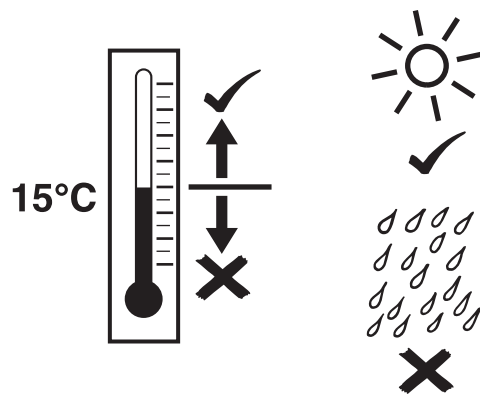

1

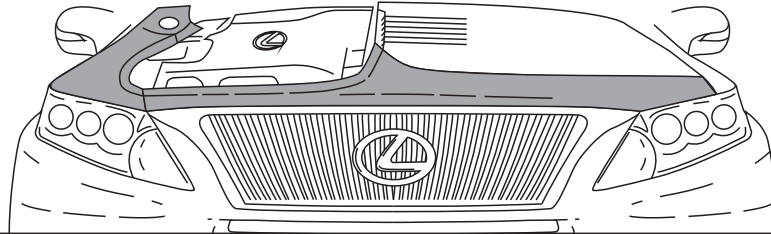
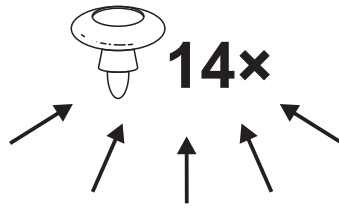

2

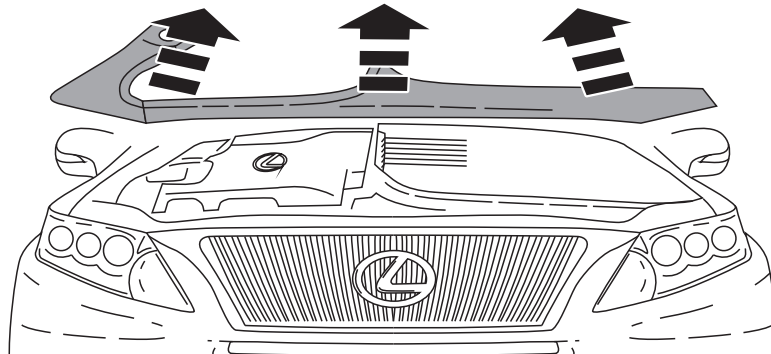

3

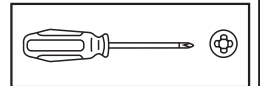
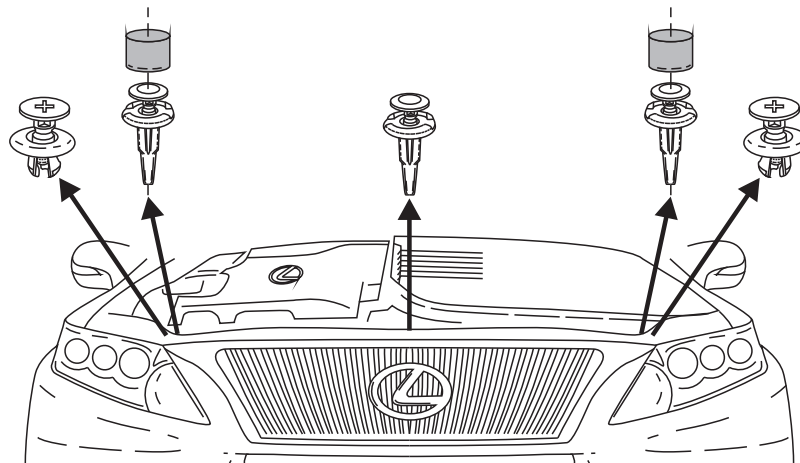

4

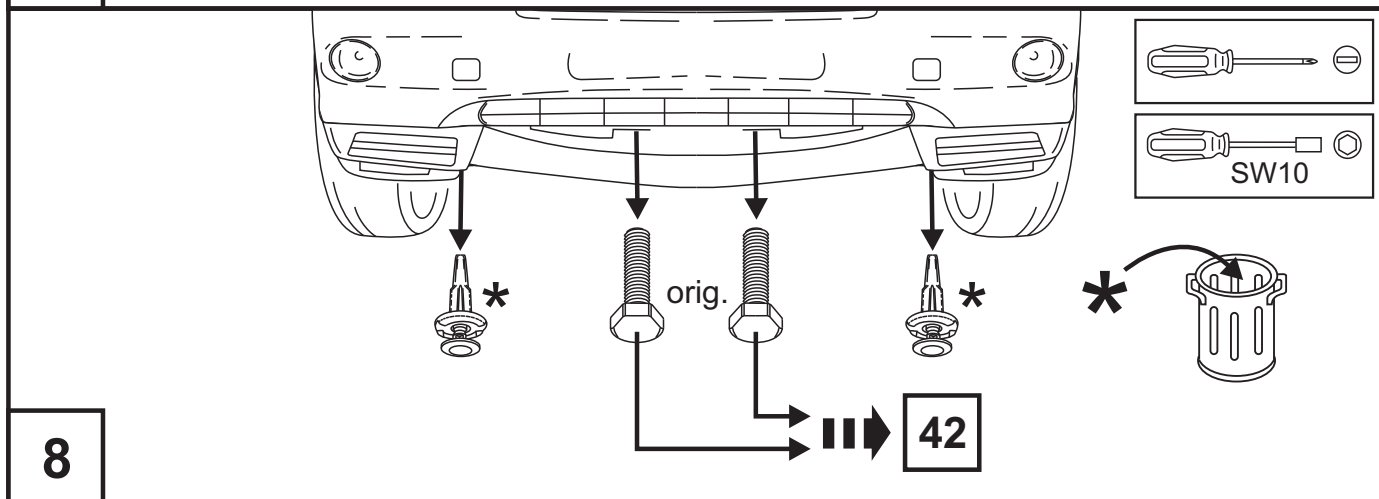
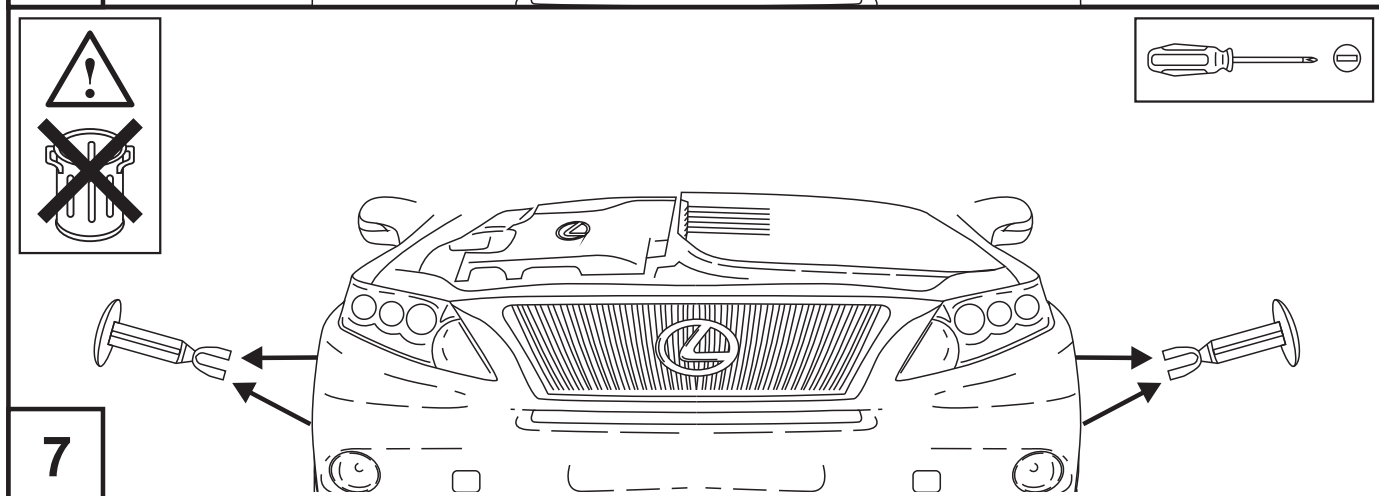
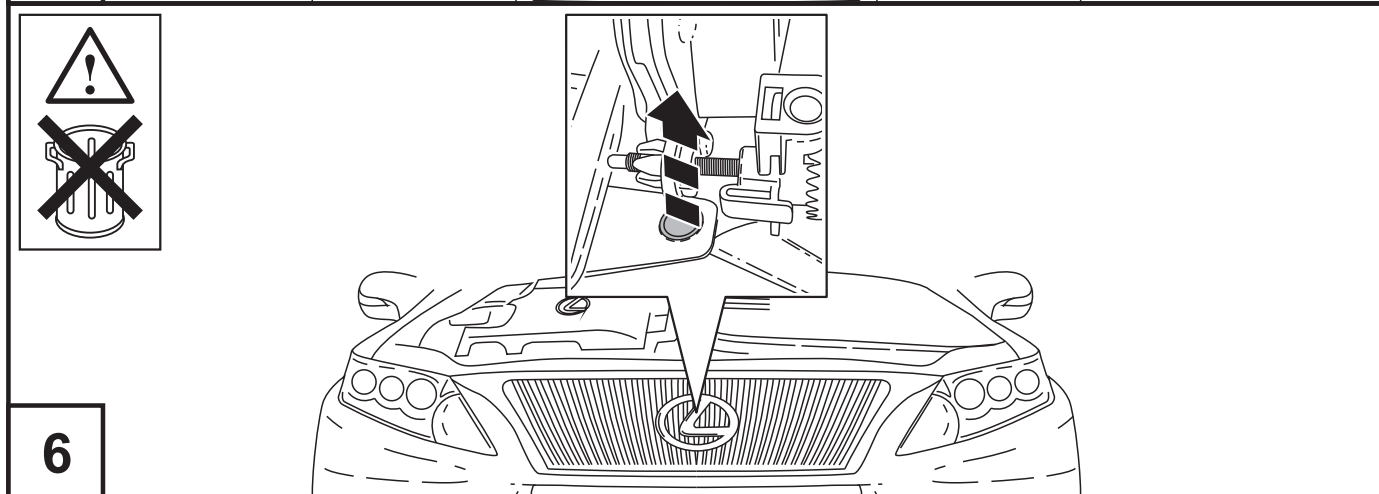
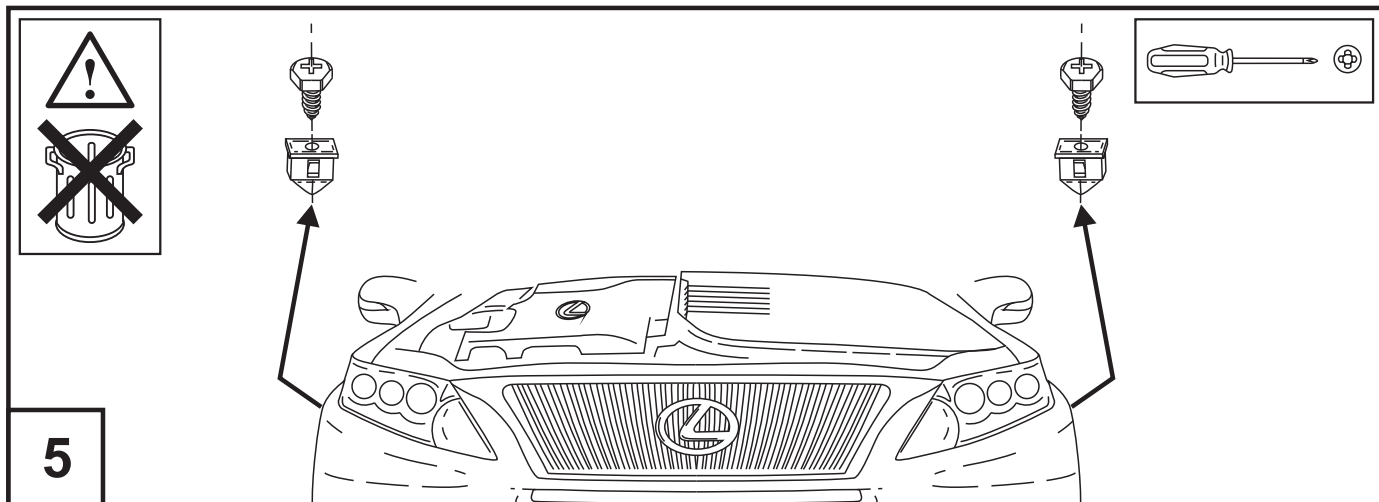

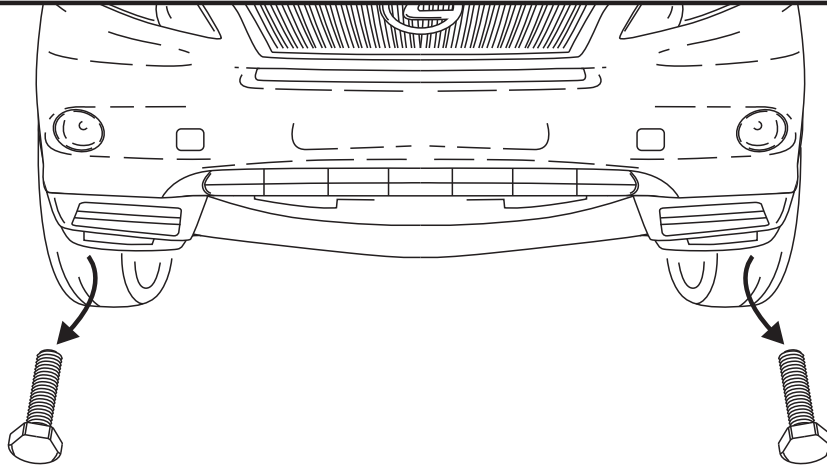

9

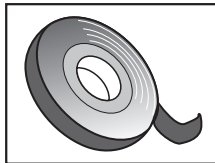
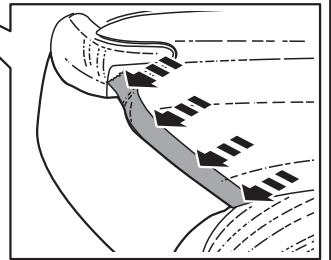
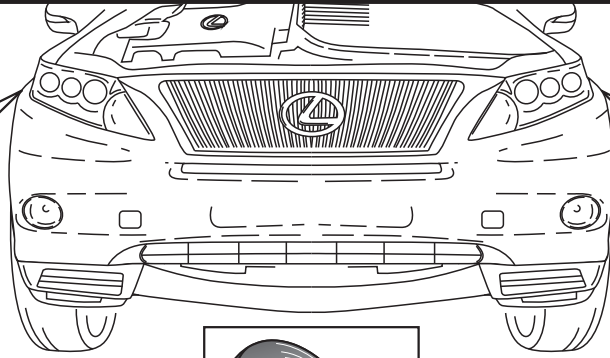
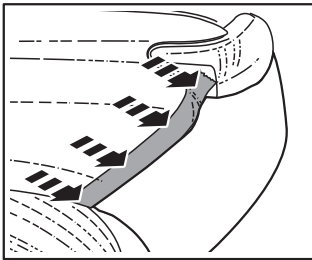

10

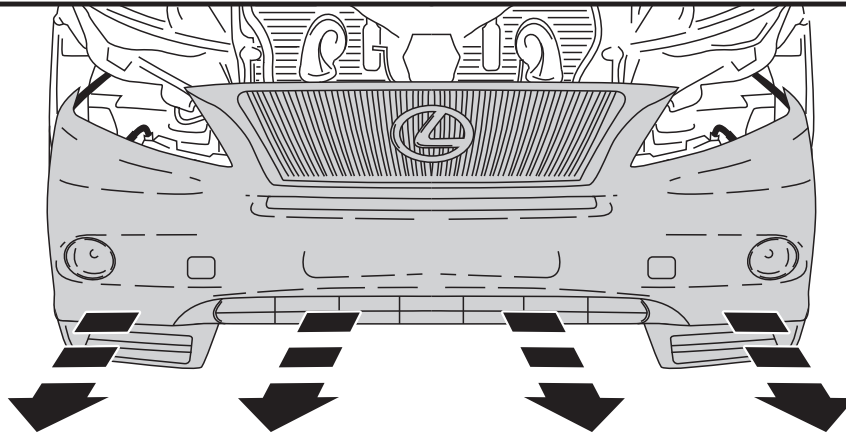
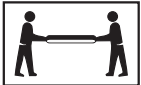

11

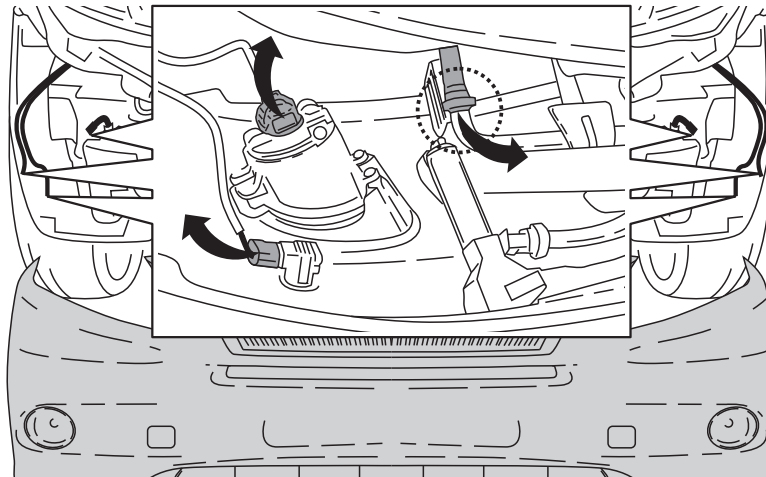
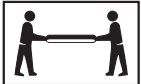

12

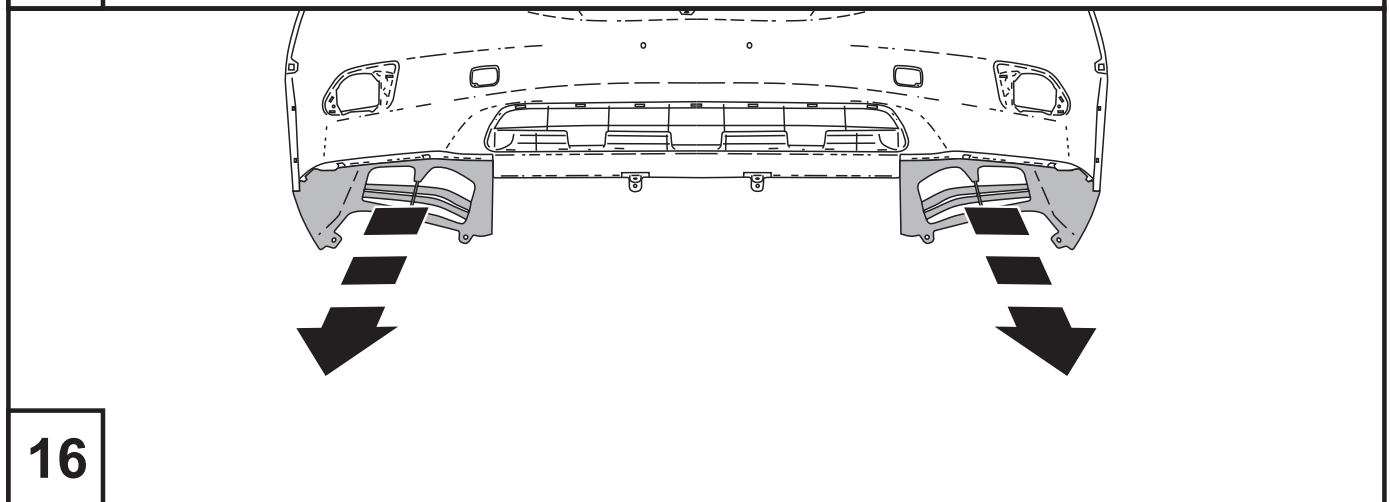
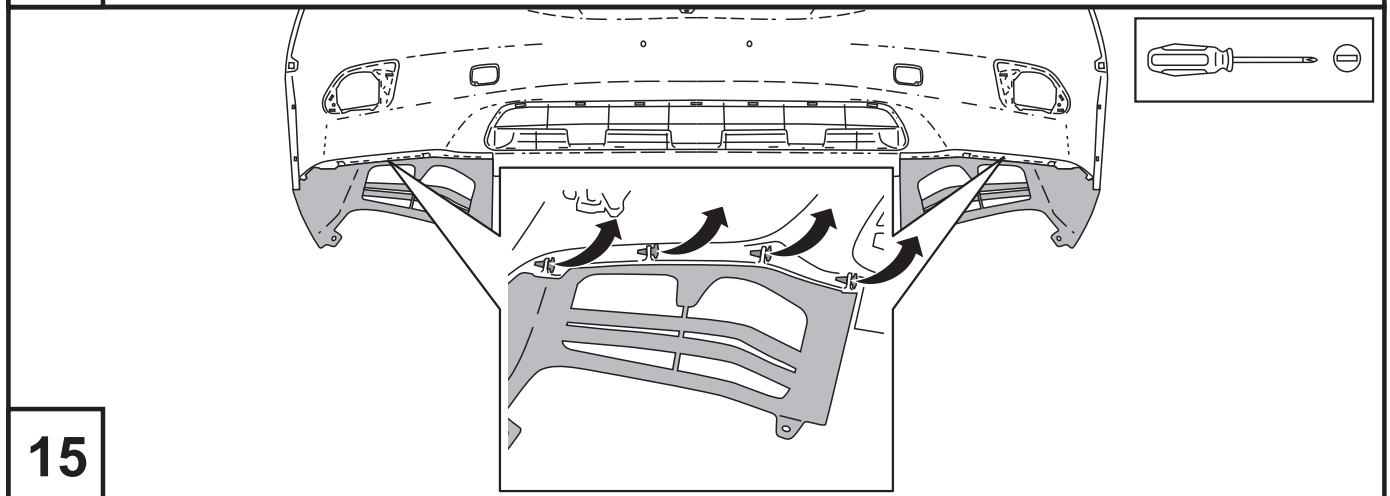
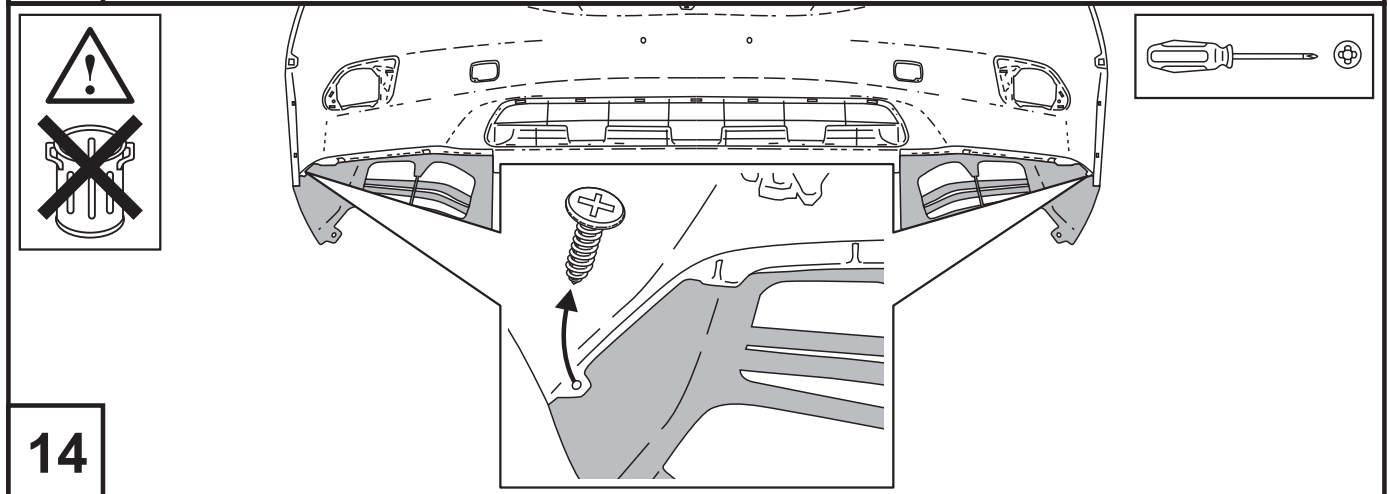
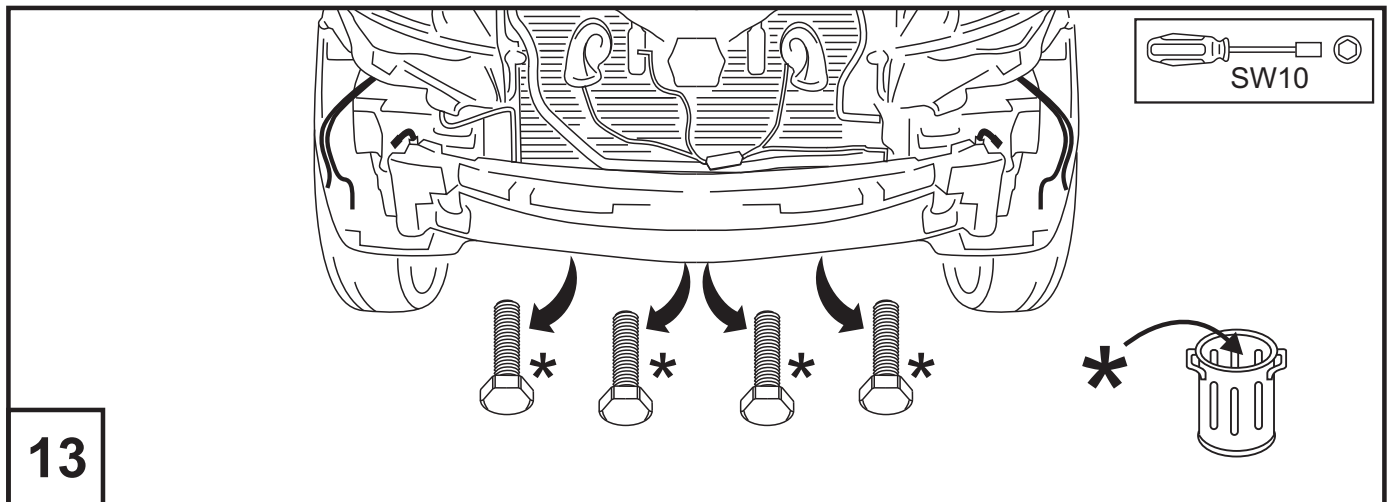

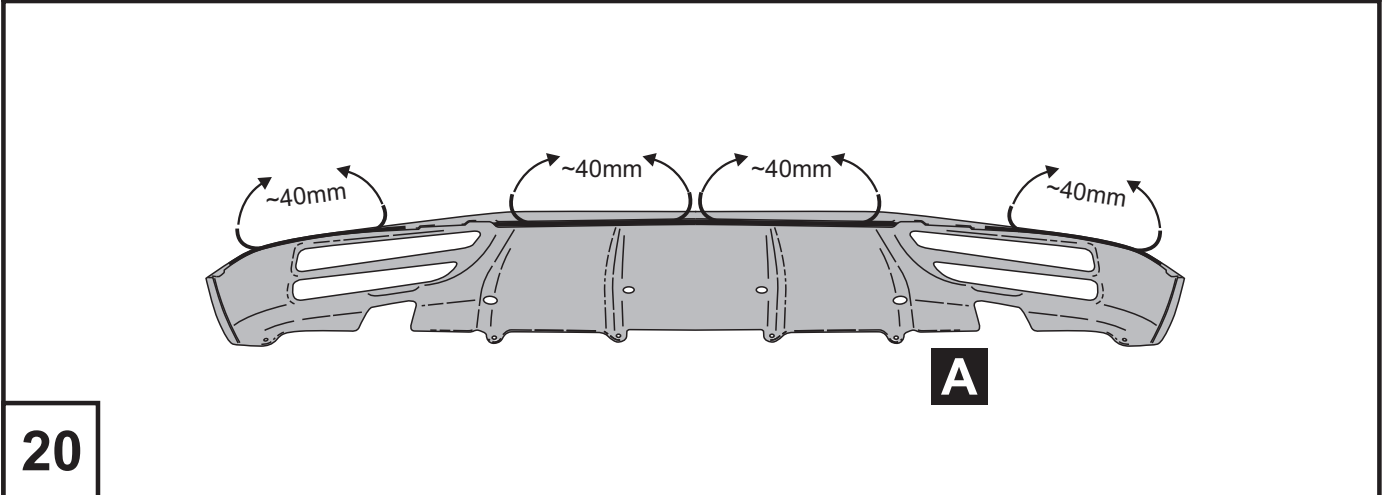
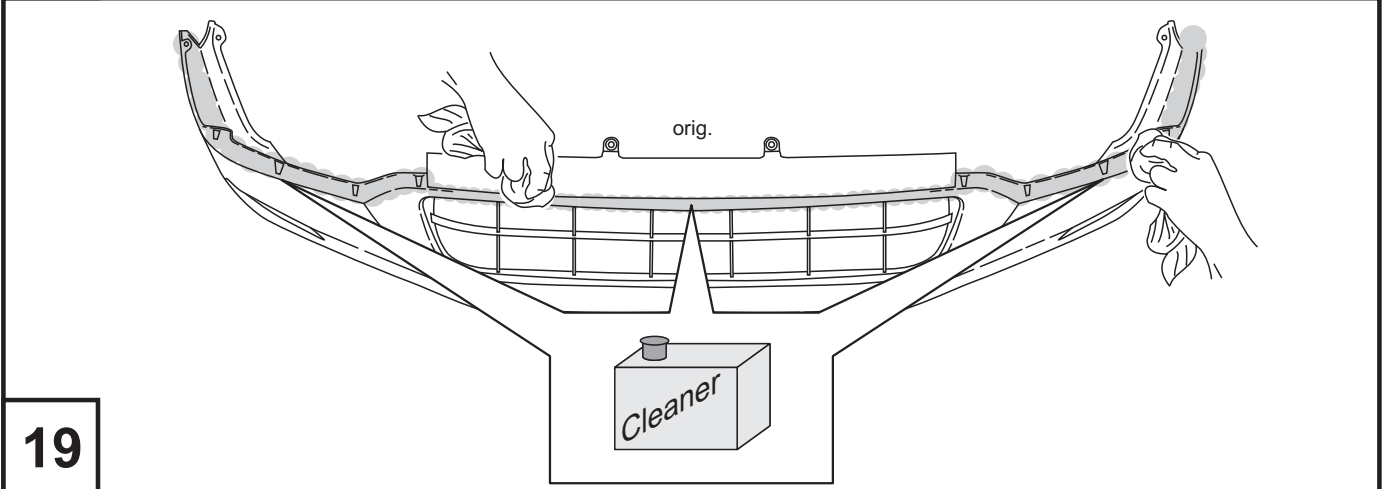
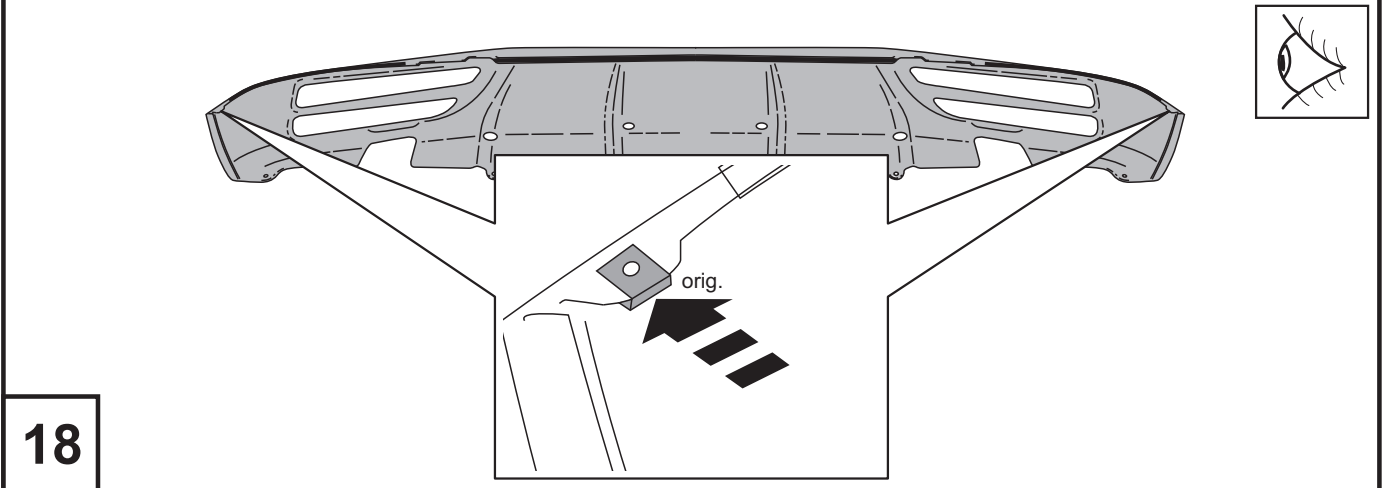
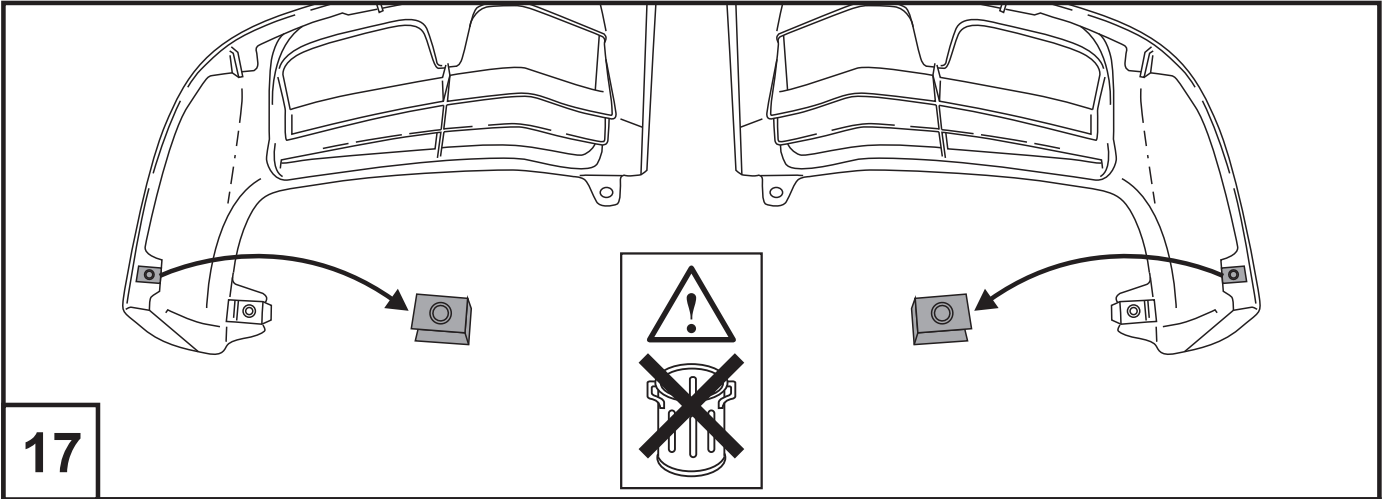

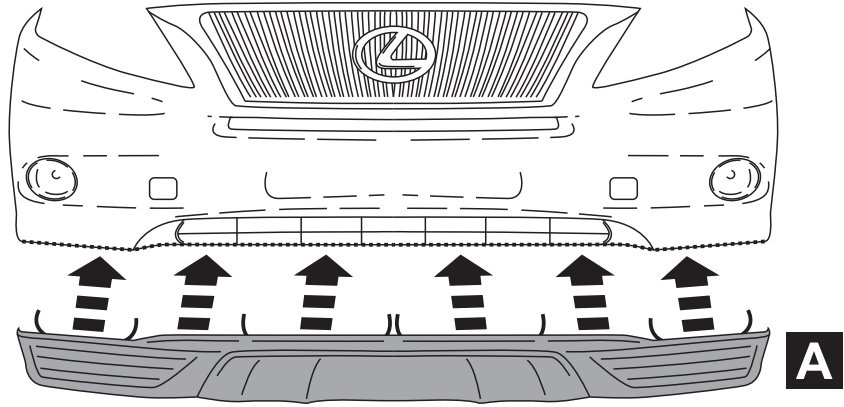
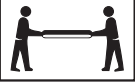

21

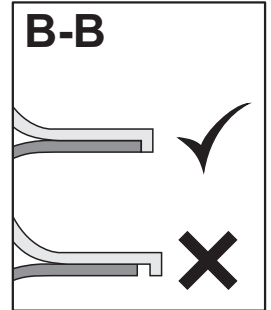
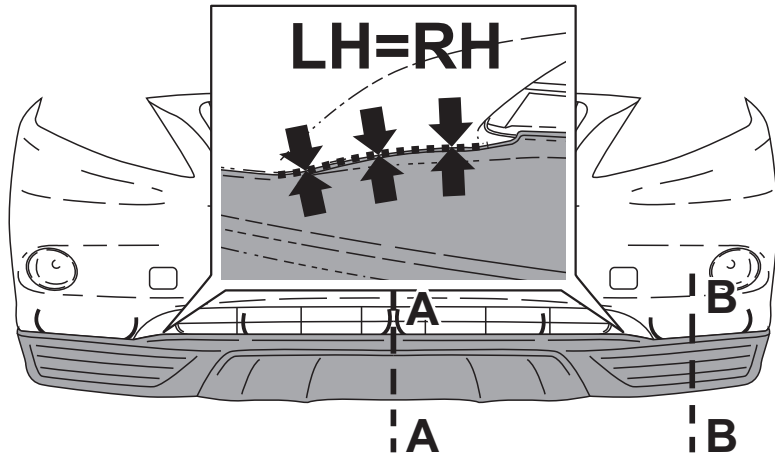
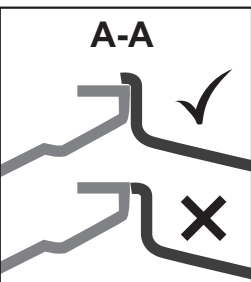
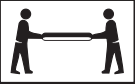

22

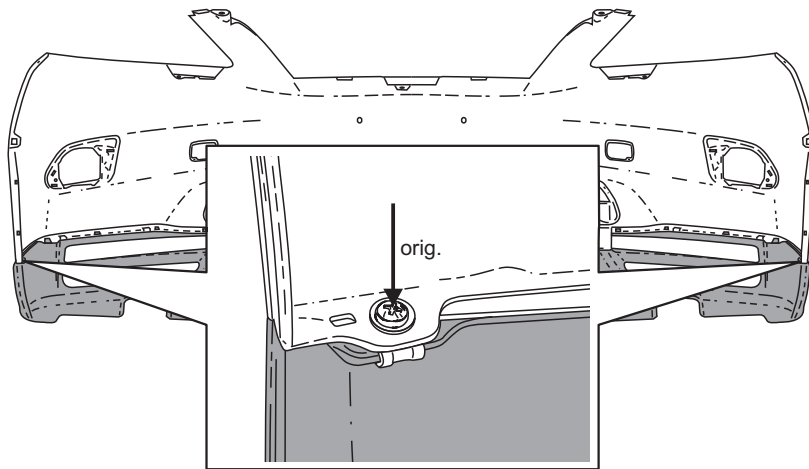
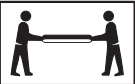
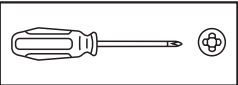

23

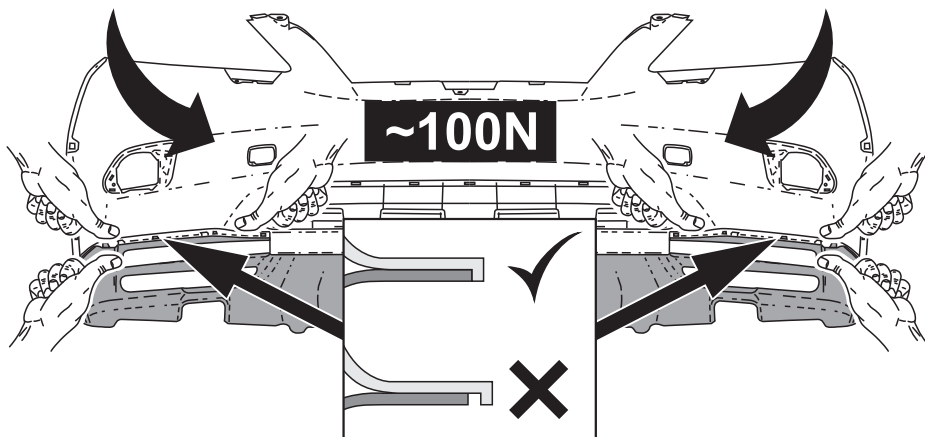
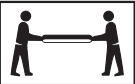

24

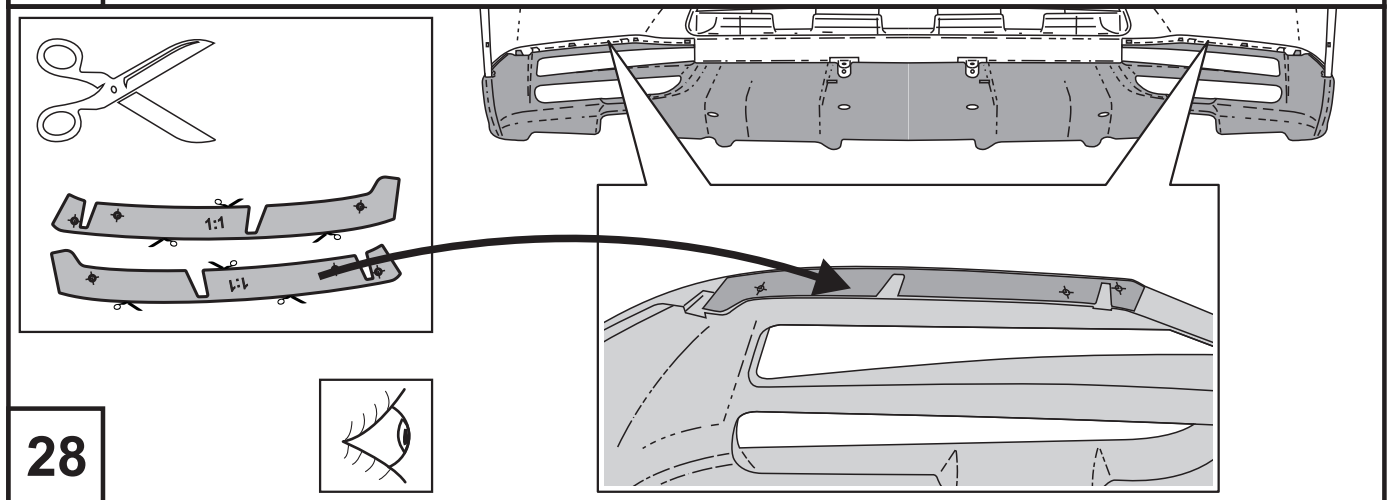
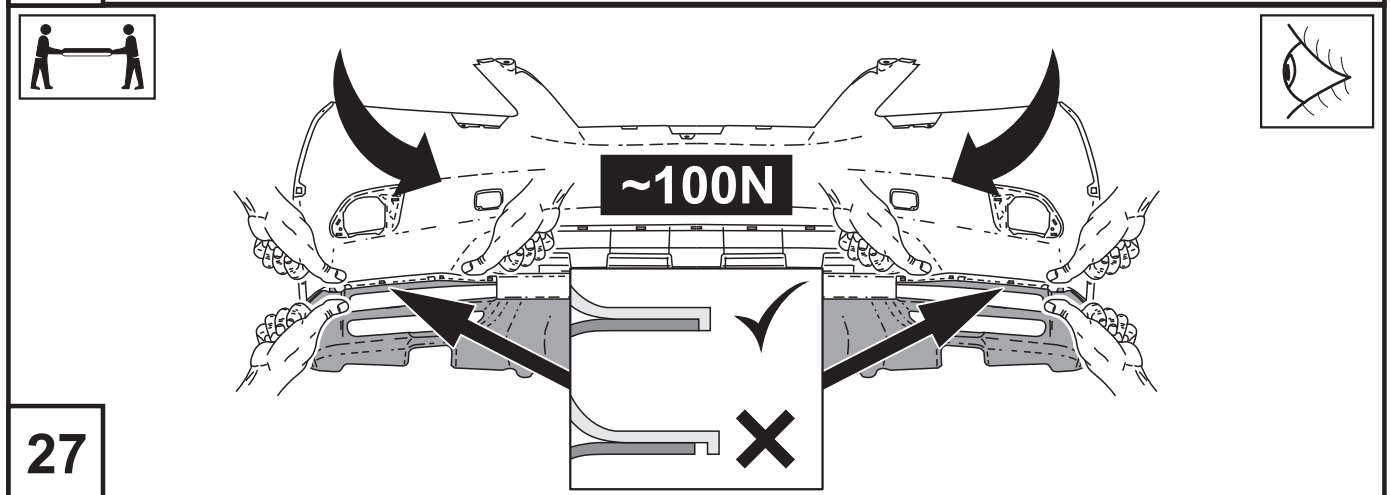
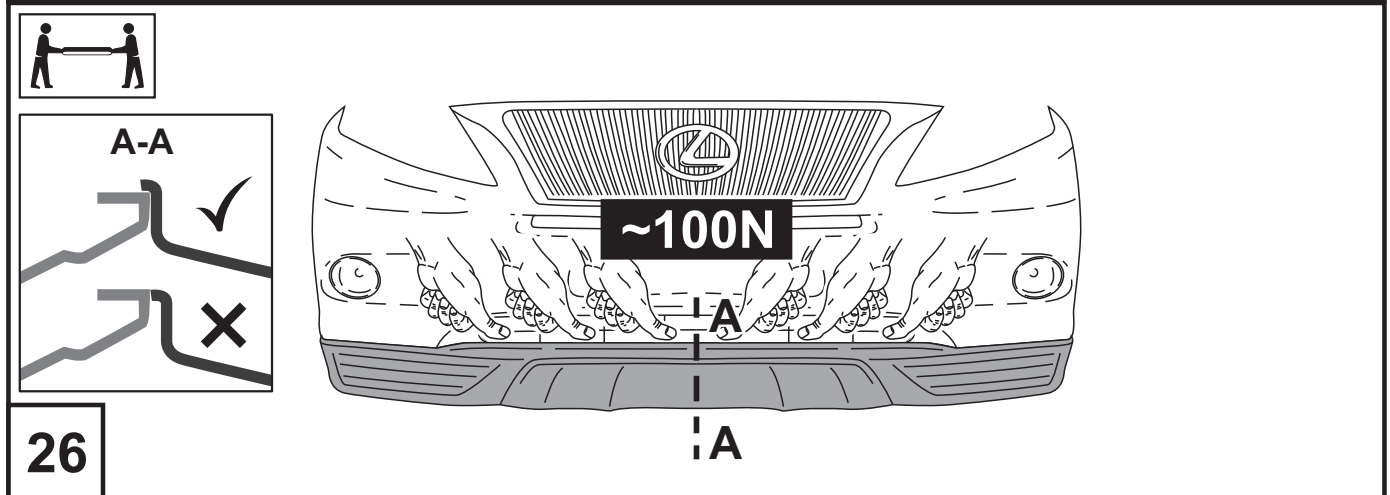
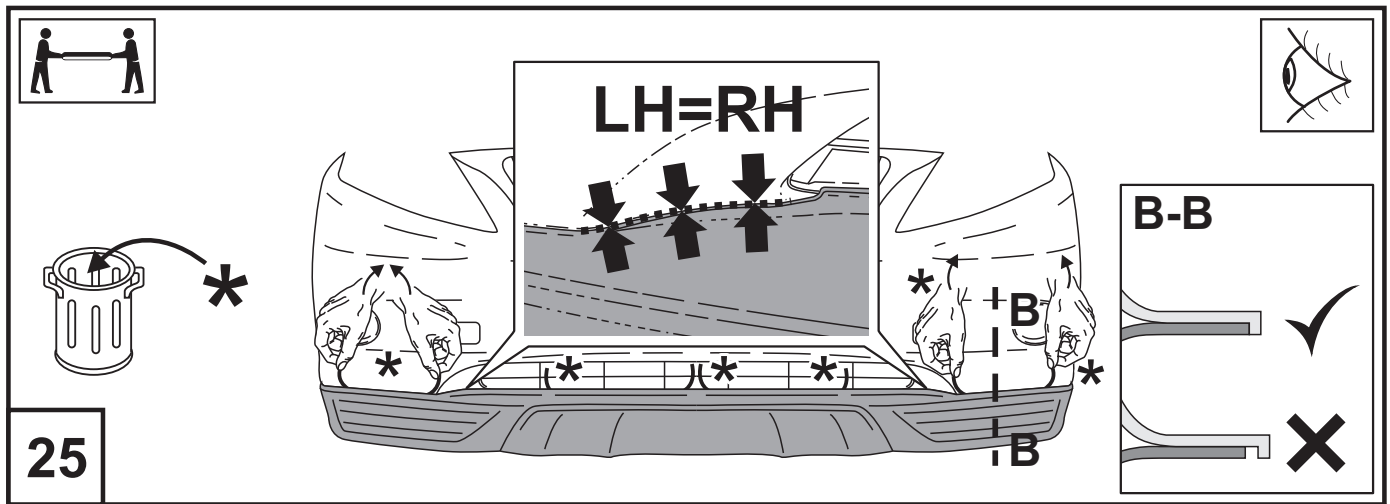

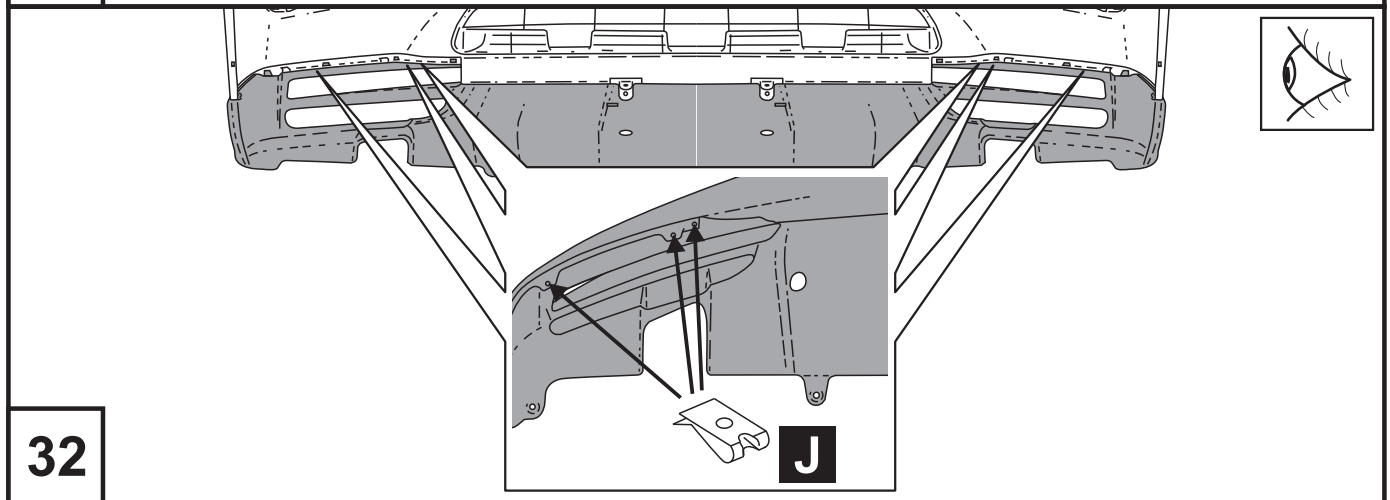
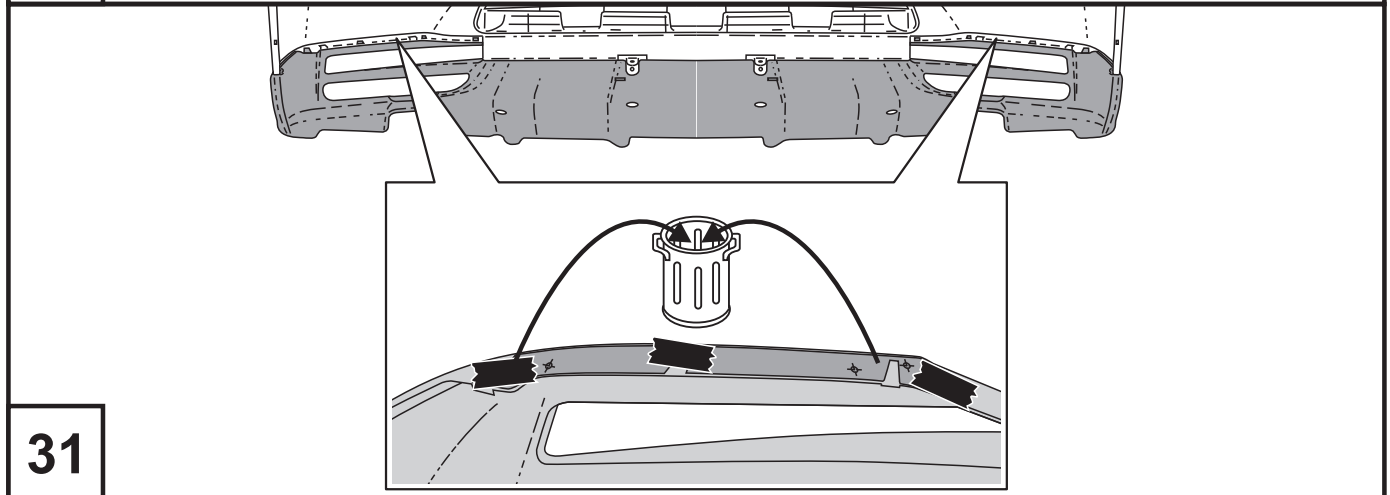
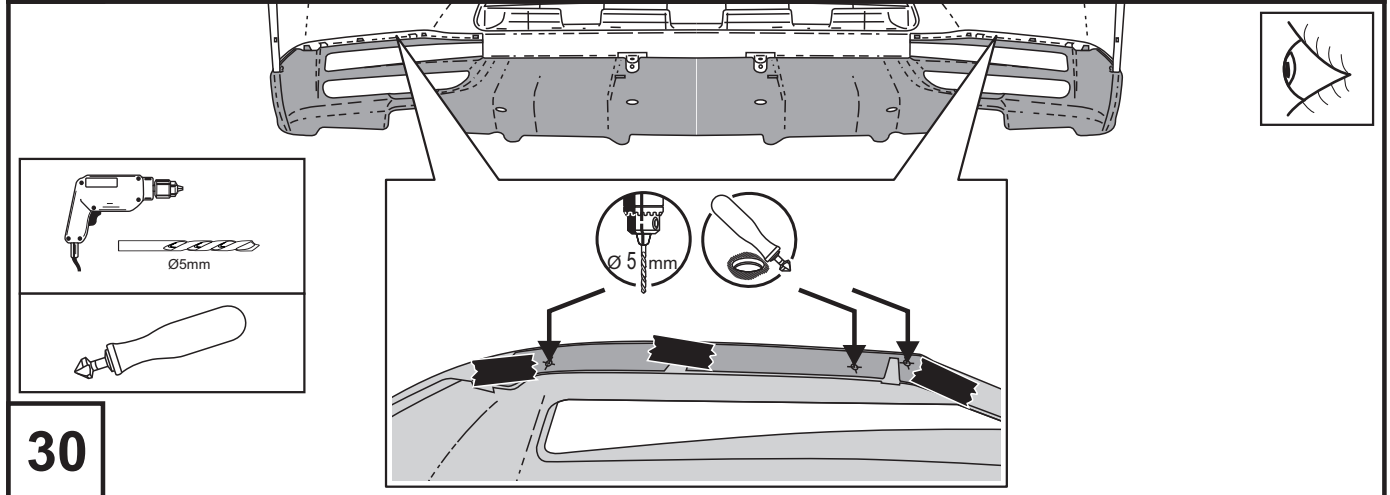
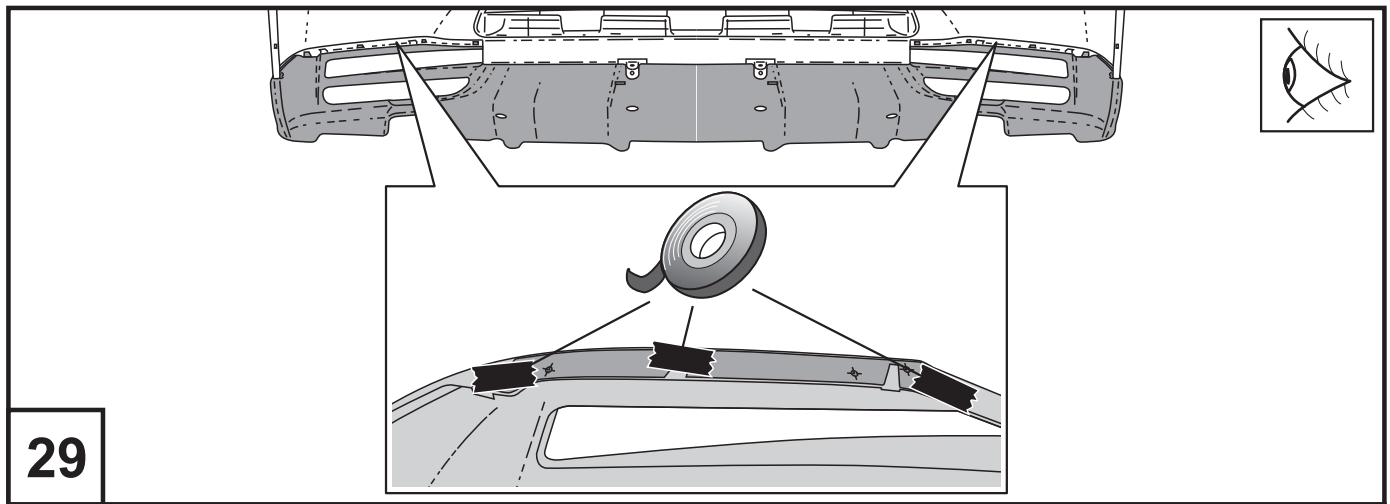

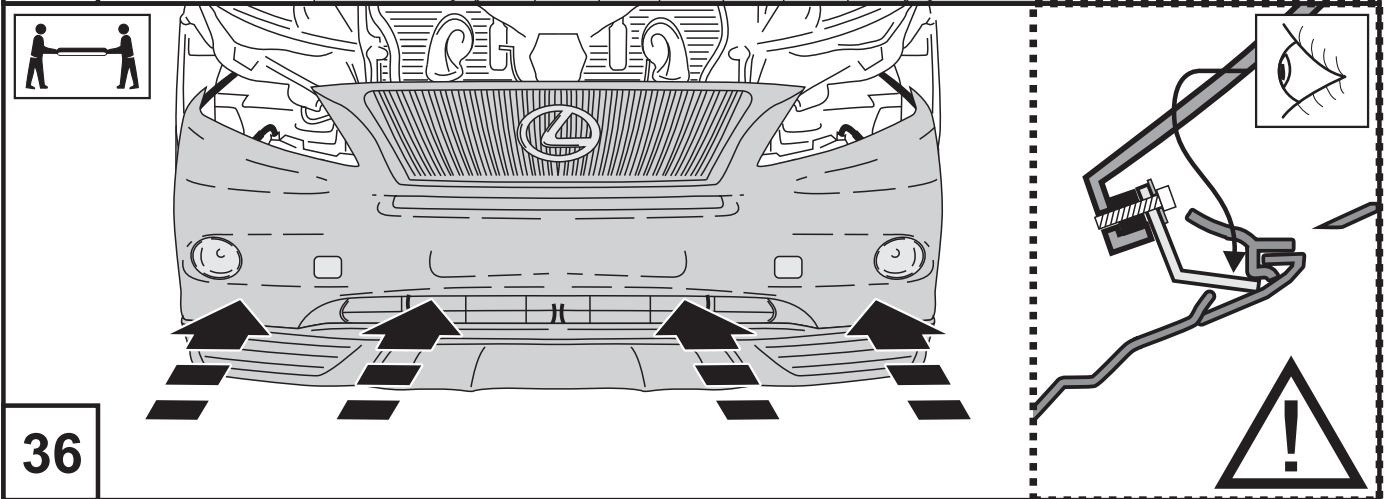
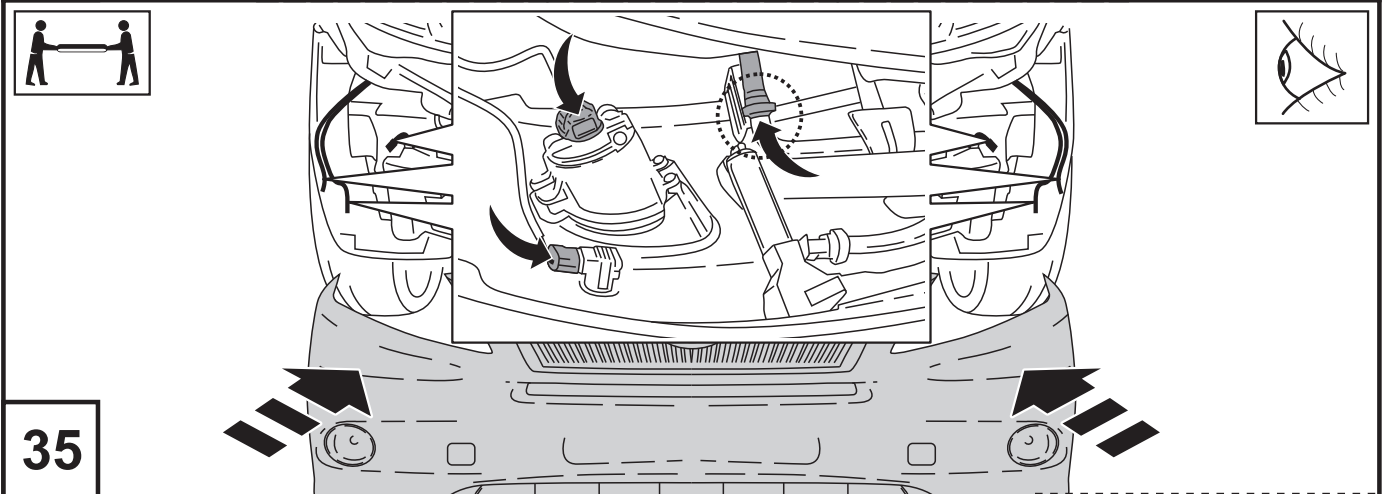
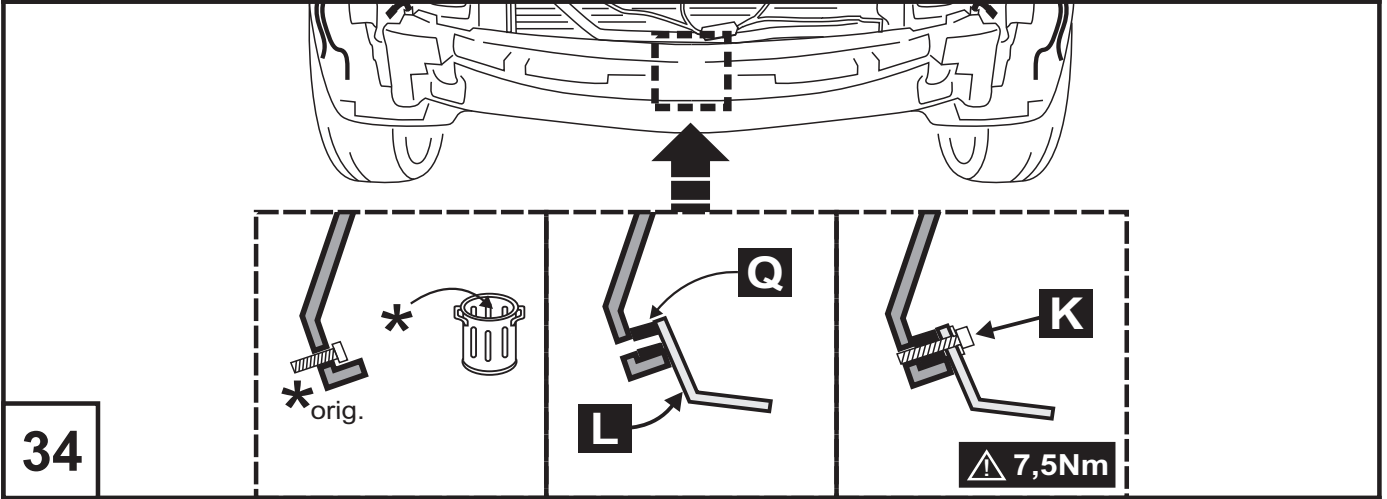
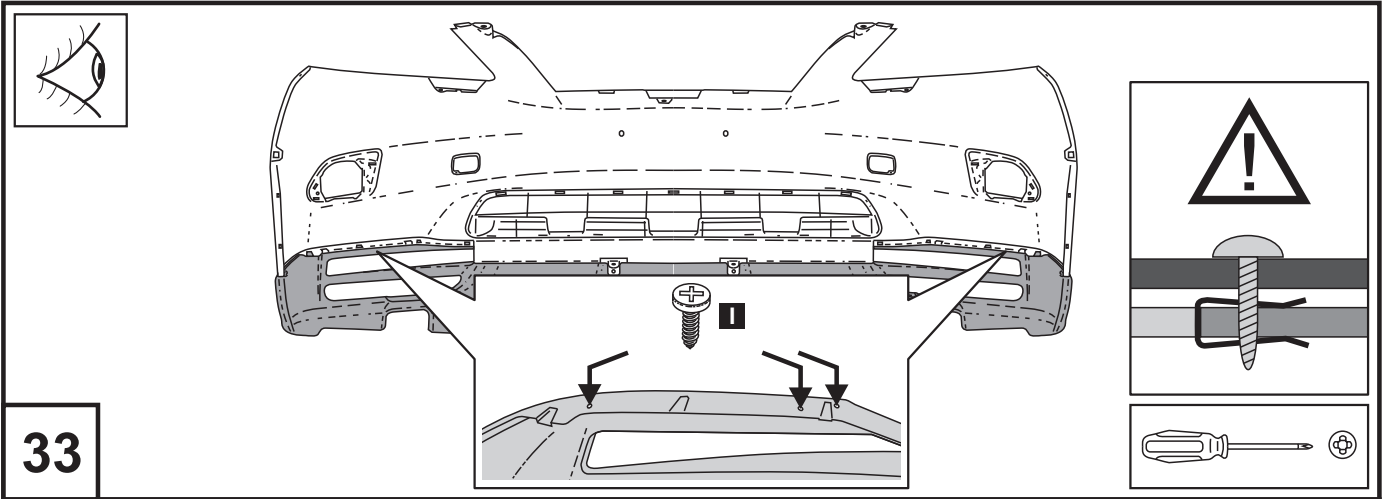

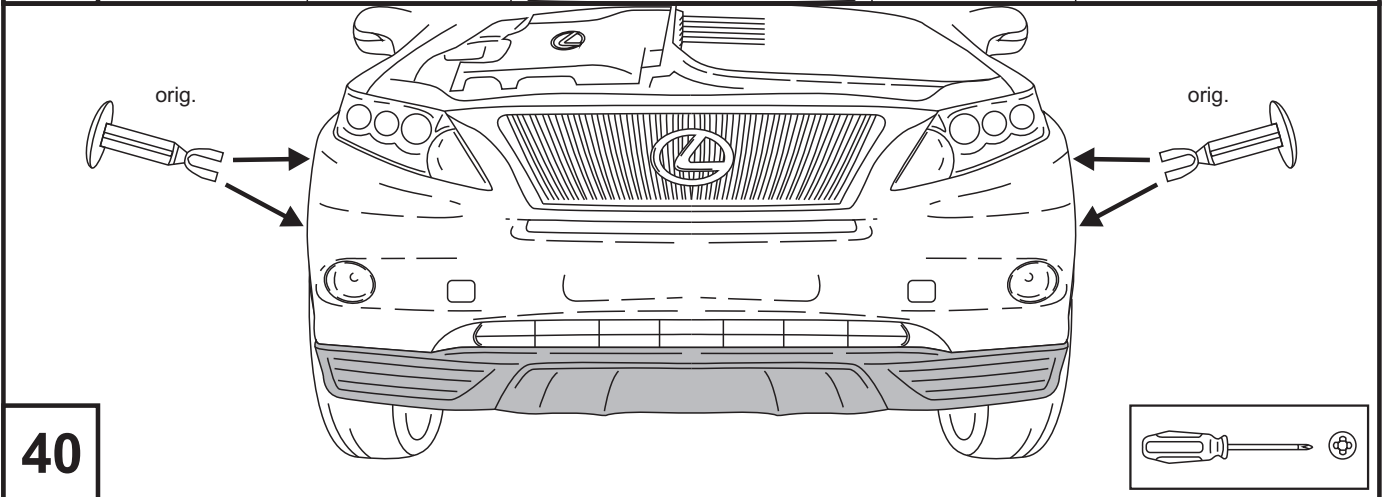
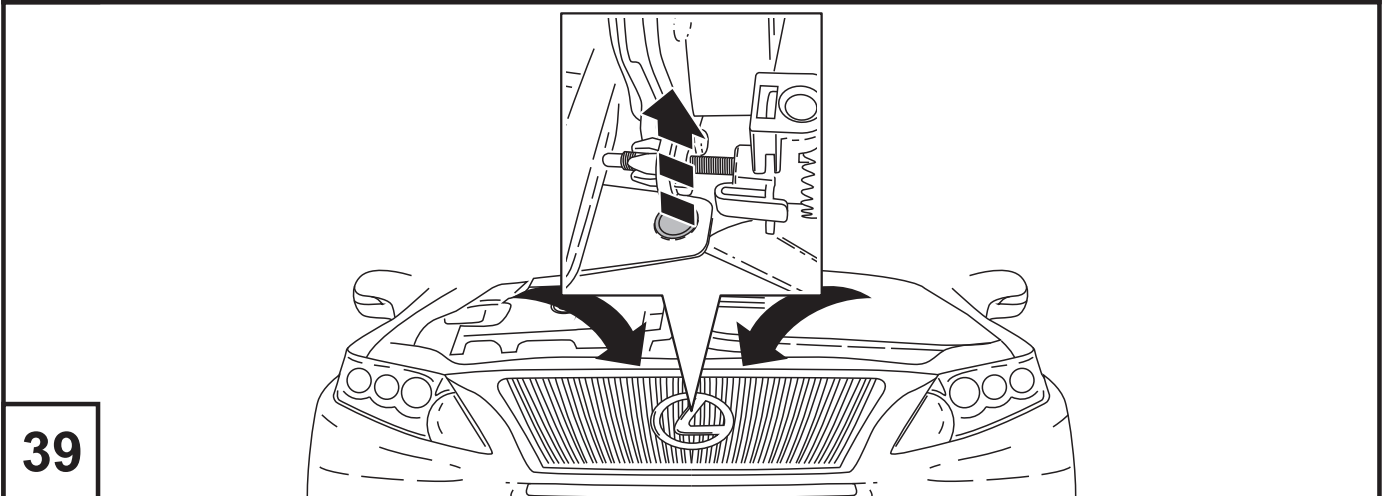
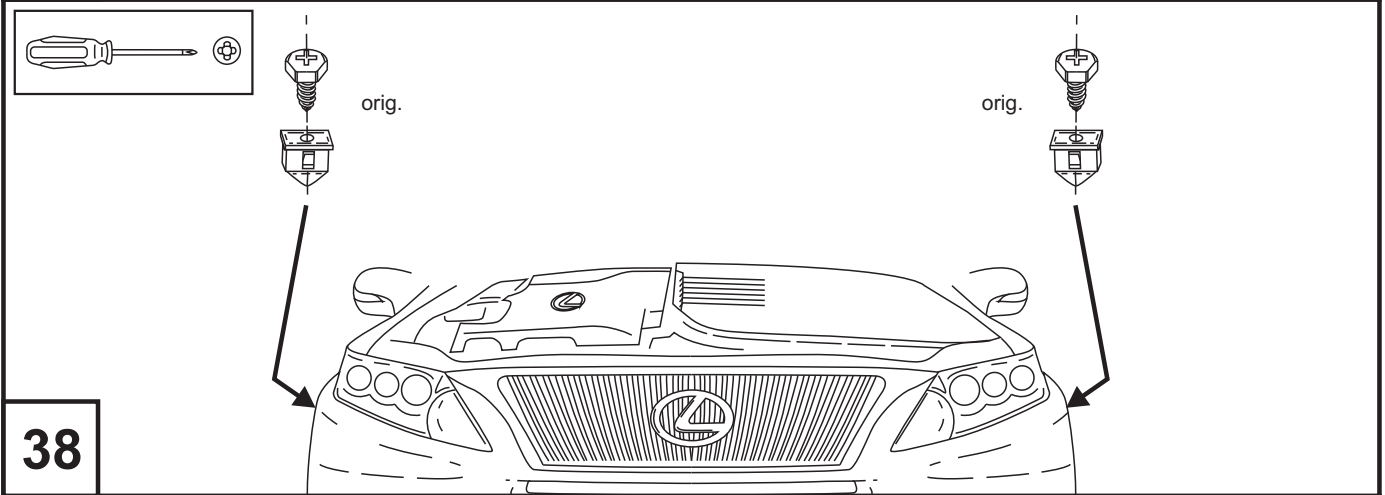
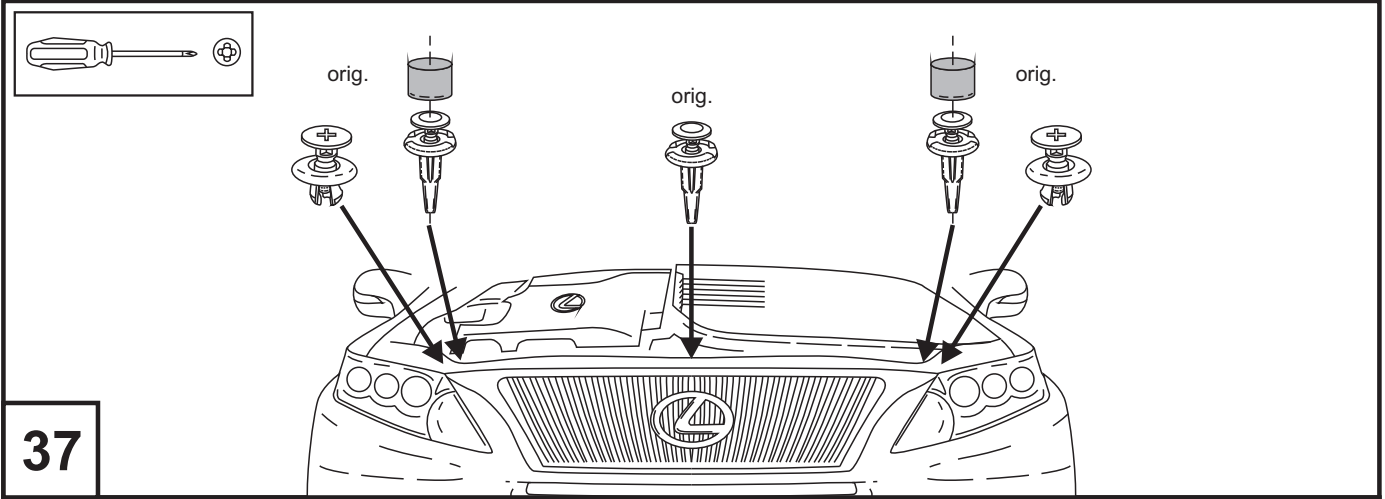

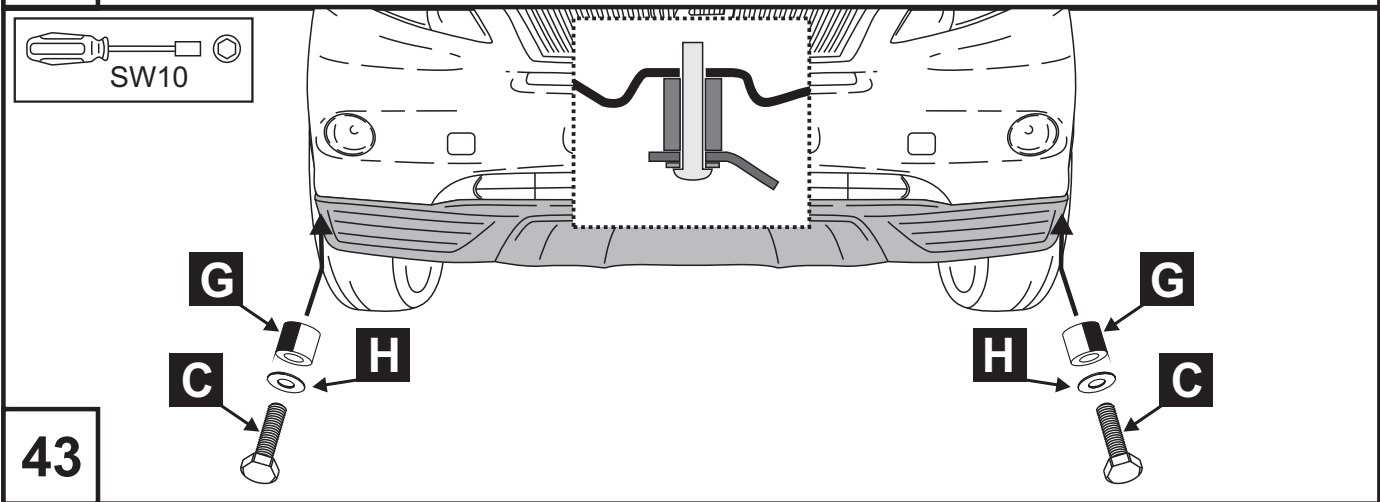
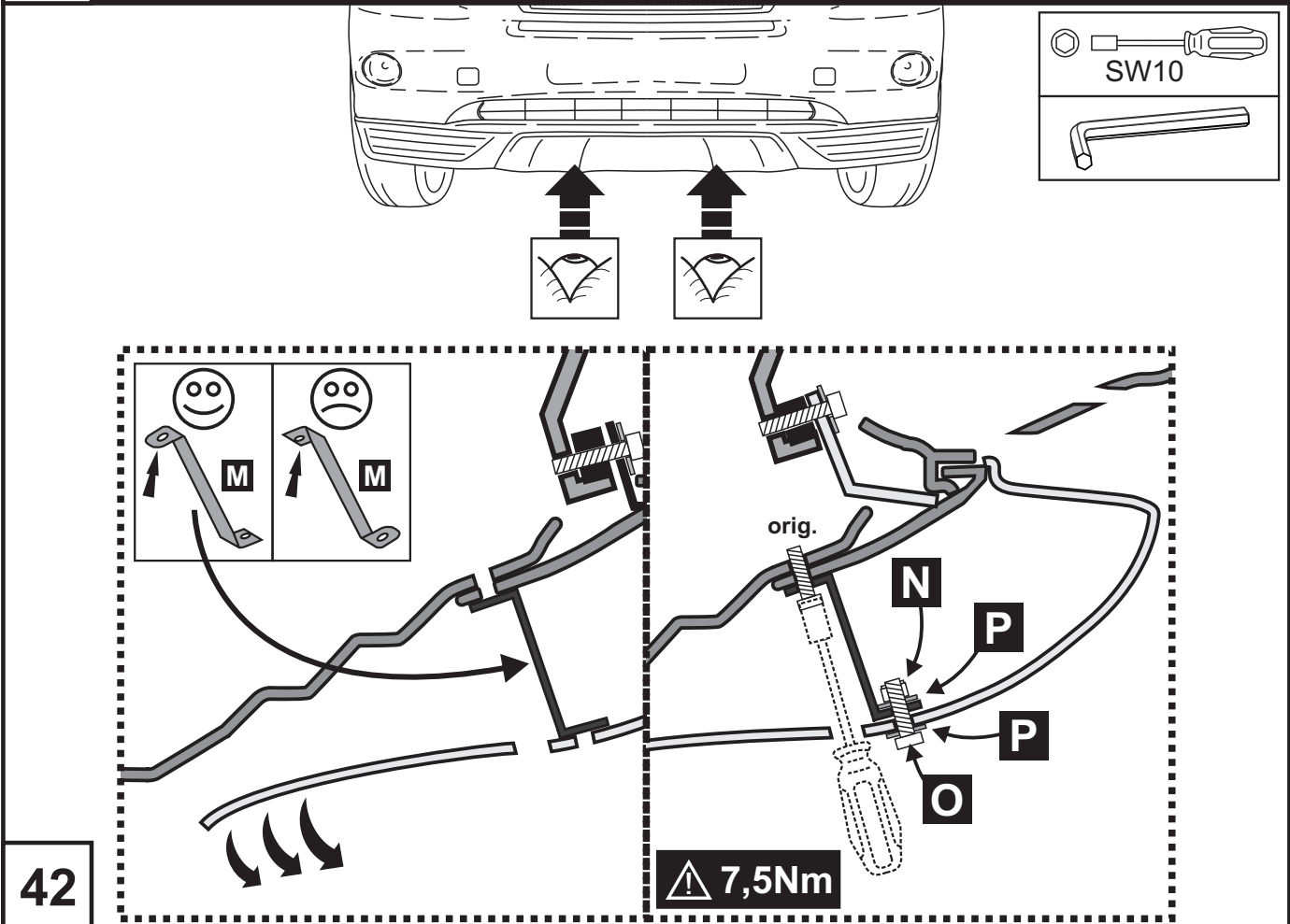
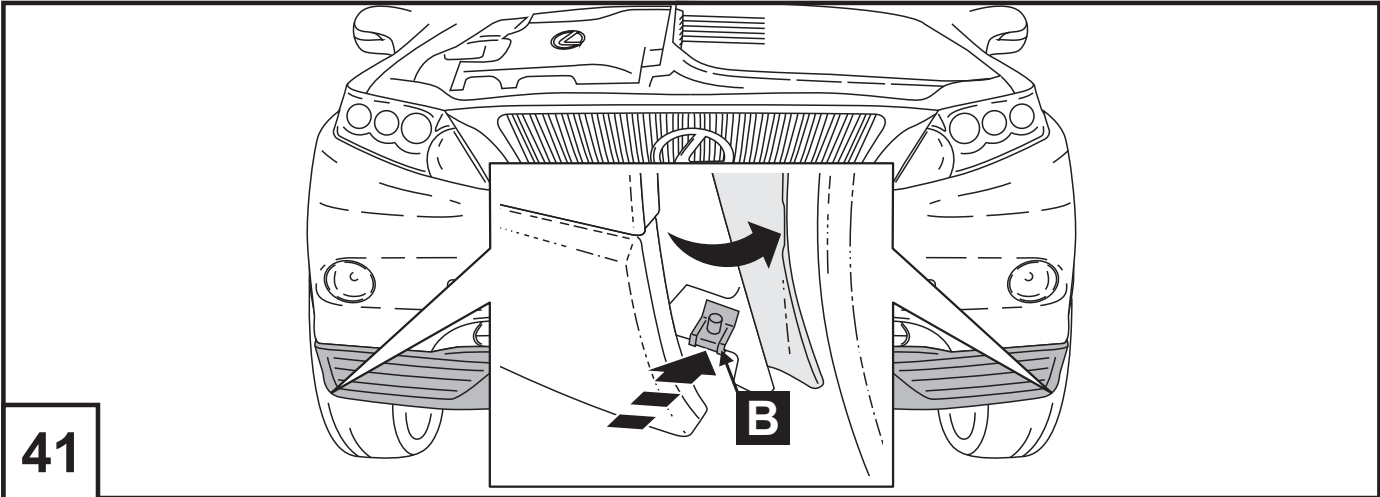

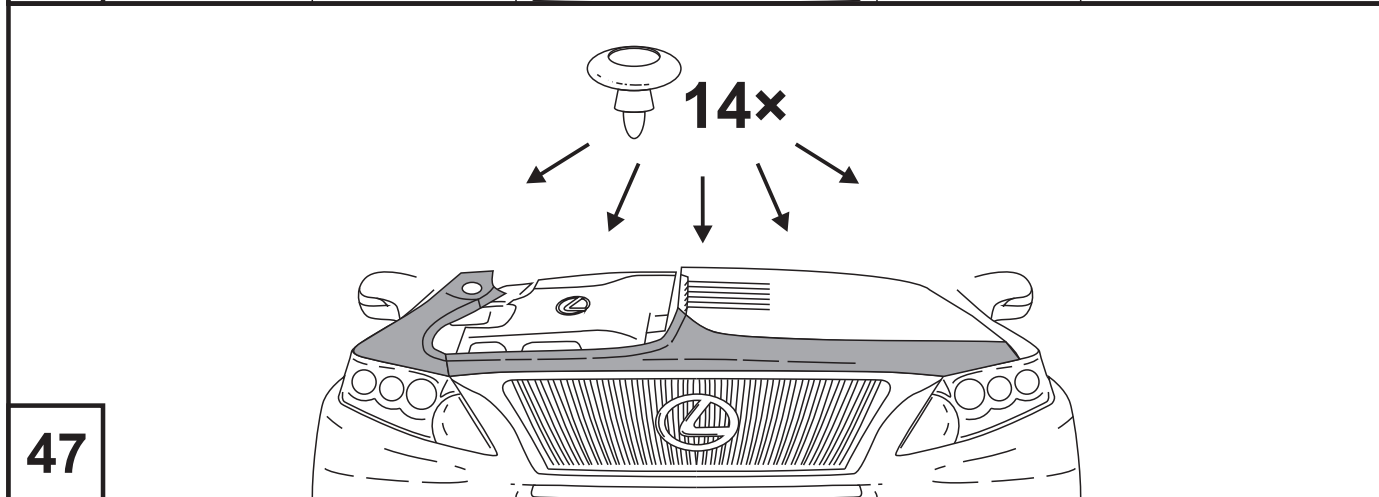
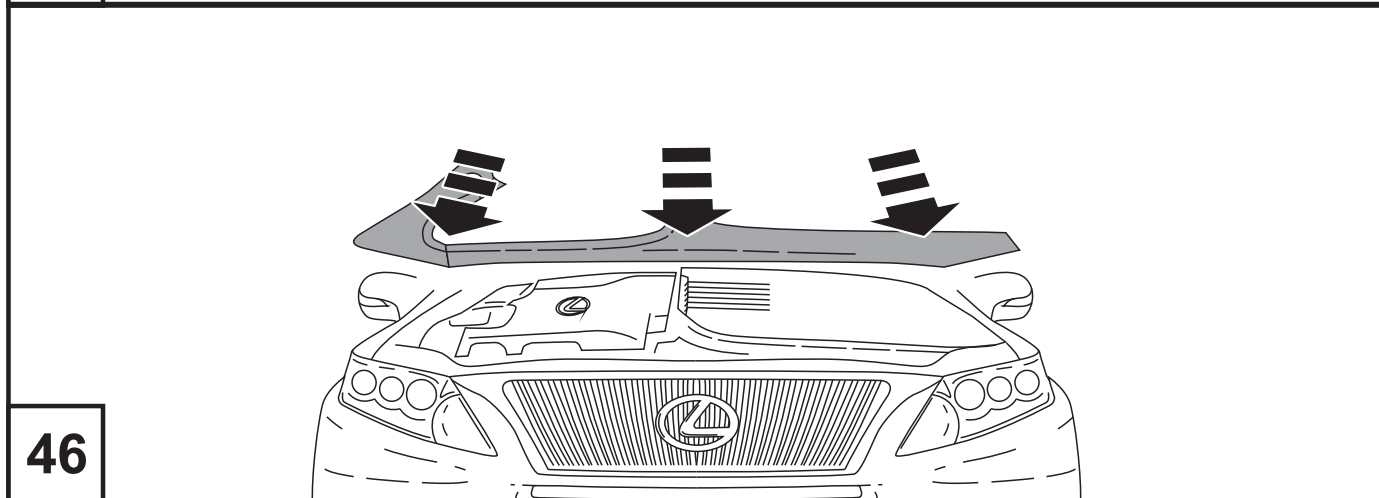
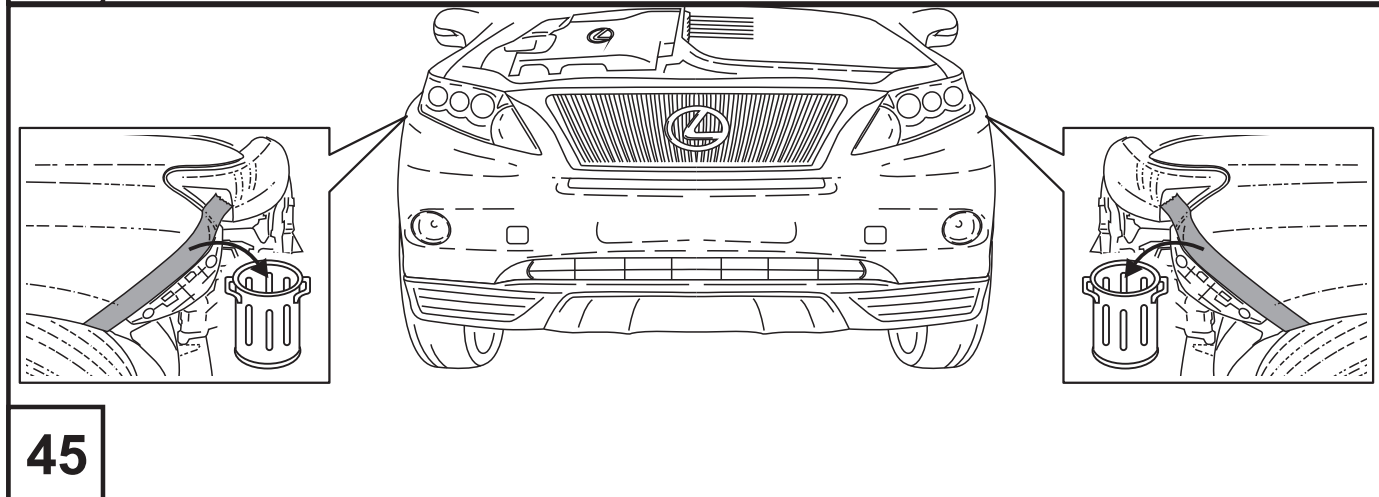
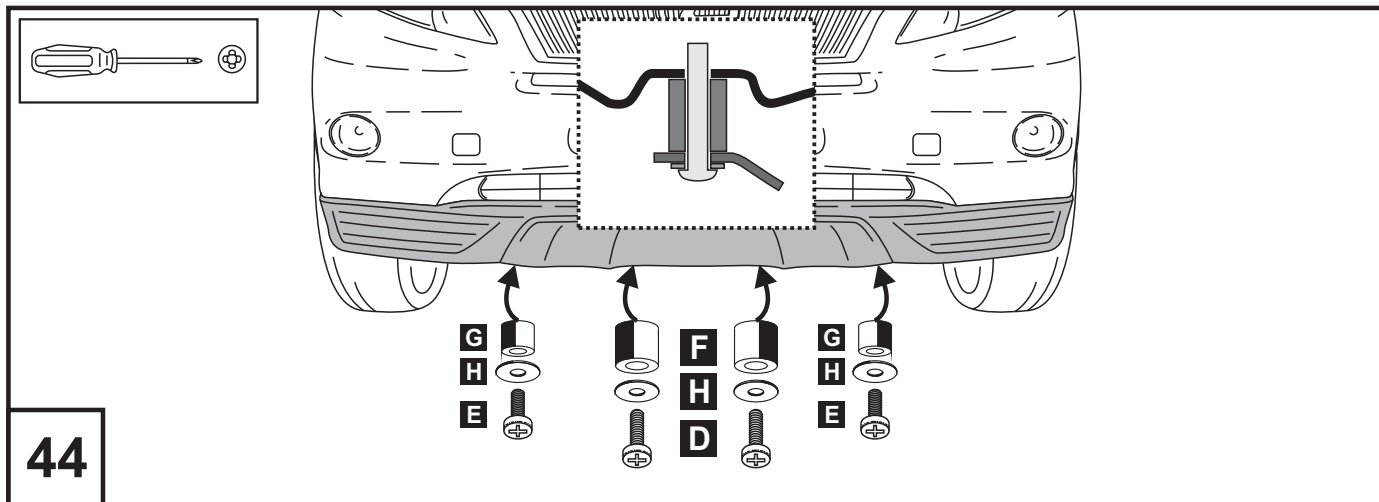

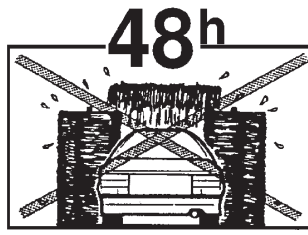
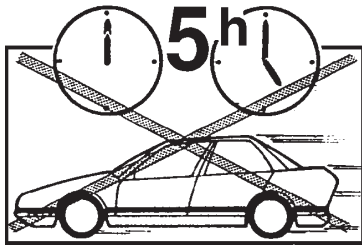

**ATTENTION
ACHTUNG
ATTENTION**



**ATTENCION
ATTENTIE
ATTENZIONE**



Nous attirons votre attention sur le fait que toute réclamation ou demande en dommage et intérêt ne pourrait être formulée que tant que le montage aura été fait suivant les instructions techniques prévues pour notre produit. Il est expressément prévu qu' on ne saurait se prévaloir d' un quelconque préjudice contractuel ou réhibitoire si le montage avait été fait en dépit des dites instructions ou dans un garage ne disposant pas des équipements adéquats.

Le type-nr. **PZ402-K0950-00**

est construit pour le véhicule indiqué ci-dessus et ne peut être monter que sur ce véhicule. Pour la fixation, utiliser exclusivement les éléments ci-joints.



Atención! Pretensiones de garantía respectivamente toda clase de reclamaciones a indemnización por daños y perjuicios pueden considerarse por nosotros solamente en caso de un montaje debidamente ejecutado en un taller especializado. Llamamos expresadamente su atención al hecho que un montaje no apropiado y no efectuado en un taller especializado tendrá por consecuencia la renuncia al ejercicio de toda clase, sobre todo originando del título de ley sobre la responsabilidad para productos defectuosos.

El tipo: **PZ402-K0950-00**

está construido para el vehículo arriba mencionado y puede montarse exclusivamente sobre este vehículo. Para su fijación se usarán únicamente las piezas de fijación adjuntas.



Achtung! Etwaige Gewährleistungsansprüche bzw. Schadenersatzansprüche aller Art können von uns nur bei einer ordnungsgemäßen und der Anleitung entsprechenden Montage in einer Fachwerkstätte berücksichtigt werden.

Wir weisen ausdrücklich darauf hin, daß eine unsachgemäße und nicht in einer Fachwerkstätte durchgeführte Montage einen Verzicht auf die Geltendmachung jeglicher Art insbesondere auch aus dem Titel des Produkthaftpflichtrechtes bewirkt.

Die Typ-Nr. **PZ402-K0950-00**

ist für das oben angeführte Fahrzeug konstruiert und darf nur auf diesem Fahrzeug montiert werden.

Für die Befestigung sind ausschließlich die beiliegenden Befestigungsteile zu verwenden.



Attentie! Een claim op garantie, resp. op schadeloosstelling, van welke aard ook, kan door ons slechts worden gehonoreerd indien ons produkt deskundig en overeenkomstig de voorschriften door een vakkundige werkplaats gemonteerd is. Wij wijzen er met nadruk op, dat ondeskundige en niet door een vakkundige werkplaats uitgevoerde montage tot gevolg heeft dat daardoor ieder recht op schadevergoeding, ook op wettelijke aansprakelijkheid inzake producten, vervalt.

Typ-nr. **PZ402-K0950-00**

is voor het boven genoemde voertuig geconstrueerd en mag alleen op dit voertuig gemonteerd worden.

Voor de bevestiging behoren uitsluitend de bijliggende bevestigingsdelen gebruikt te worden.



Important note! Guarantee claims/compensation claims of all kinds can only be entertained by us if assembly has been carried out properly and in accordance with instructions in a specialist workshop.

We would expressly point out that any improper assembly which is not carried out in a specialist workshop will result in the renunciation of the enforcement of compensation claims of any kind, in particular those arising by virtue of the product liability law.

The typ no.: **PZ402-K0950-00**

is constructed for the above vehicle and can only be mounted on said vehicle. For the purpose of fixing, please use the attached fixing parts only.



Attenzione! Qualsiasi diritto a garanzia o diritto al risarcimento del danno può essere preso in considerazione solo in caso di un montaggio eseguito in modo regolare, secondo le rispettive istruzioni, in un'officina specializzata. Si fa notare esplicitamente che, in caso di un montaggio non appropriato, fuori di un'officina specializzata, si rinuncia all'esercizio di qualsiasi diritto, soprattutto di quello derivante dal titolo della responsabilità civile del fabbricante o venditore del prodotto.

Il modell: **PZ402-K0950-00**

è stato costruito per il veicolo sopraindicato e può essere montato solo su questo veicolo. Per il fissaggio vanno usati esclusivamente gli elementi di fissaggio acclusi.



Atenção! Quaisquer reivindicações de garantia ou de indemnização apenas poderão ser consideradas por nós se a montagem foi devidamente efectuada numa oficina especializada. Chamamos expressamente a atenção para o facto de que uma montagem não efectuada devidamente e não numa oficina especializada resultará na renúncia do direito a quaisquer reivindicações, em especial á do direito sob a lei da responsabilidade de produtos.

Tipo N° **PZ402-K0950-00**

Foi construido para o veiculo acima referido e só poderá ser montado neste veiculo.

Para a fixação, utilizar apenas as peças de fixação juntas.

