



IQ

Rear Skirt

Installation instructions



Model year: 2008

Vehicle code: **J10*-BG***W













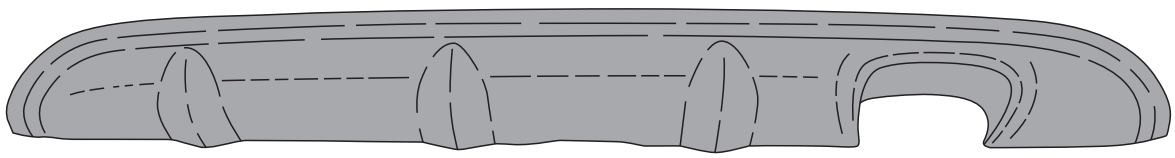
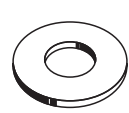

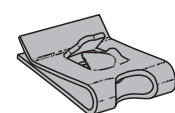

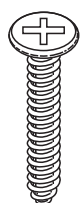
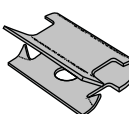
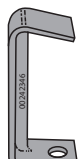

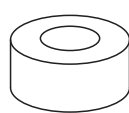
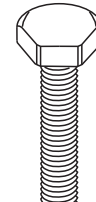
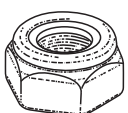
Weight: 0,8 kg

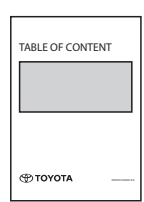
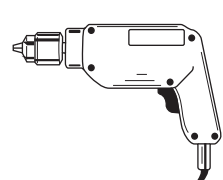
Part number: PZ402-I0640-AB

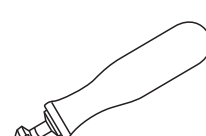
Manual reference number: AIM 001 408-3

Revision Record

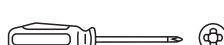
Rev. No.	Date	Page	Picture	Update	New	Deleted Steps
1	12/23/2008	3			drill machine	
1	12/23/2008	3			drill Ø3,8mm	
1	12/23/2008	3			deburrer	
1	12/23/2008	5			picture 13	
1	12/23/2008	5			picture 15	
1	12/23/2008	6			picture 22	
1	12/23/2008	6	23	Nm added		
2	03/25/2009	3		X		
2	03/25/2009	6	16	X		
2	03/25/2009	6	19	X		
2	03/25/2009	6	20	X		
2	03/25/2009	6	22	X		
3	07/07/2011	3,7	23	X		

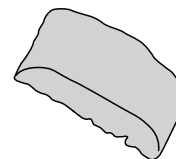
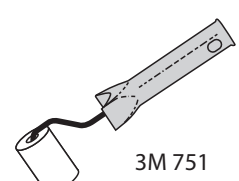
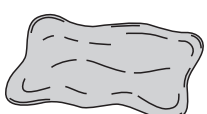
A  1x				
B  4x	C  2x	D  4x	E  4x	F  2x
G  4x	H  00242346 2x	I  00242345 2x	J  1x	
K  2x	L  2x	M  2x	N  4x	O  1x
				
 Ø3,5 mm				
		 SIKKENS M600 Spiess Hecker 7799 Panel degreaser PZ469-CL001-50		
 H ₂ O		 3M 751	 Spiess Hecker Sontora	

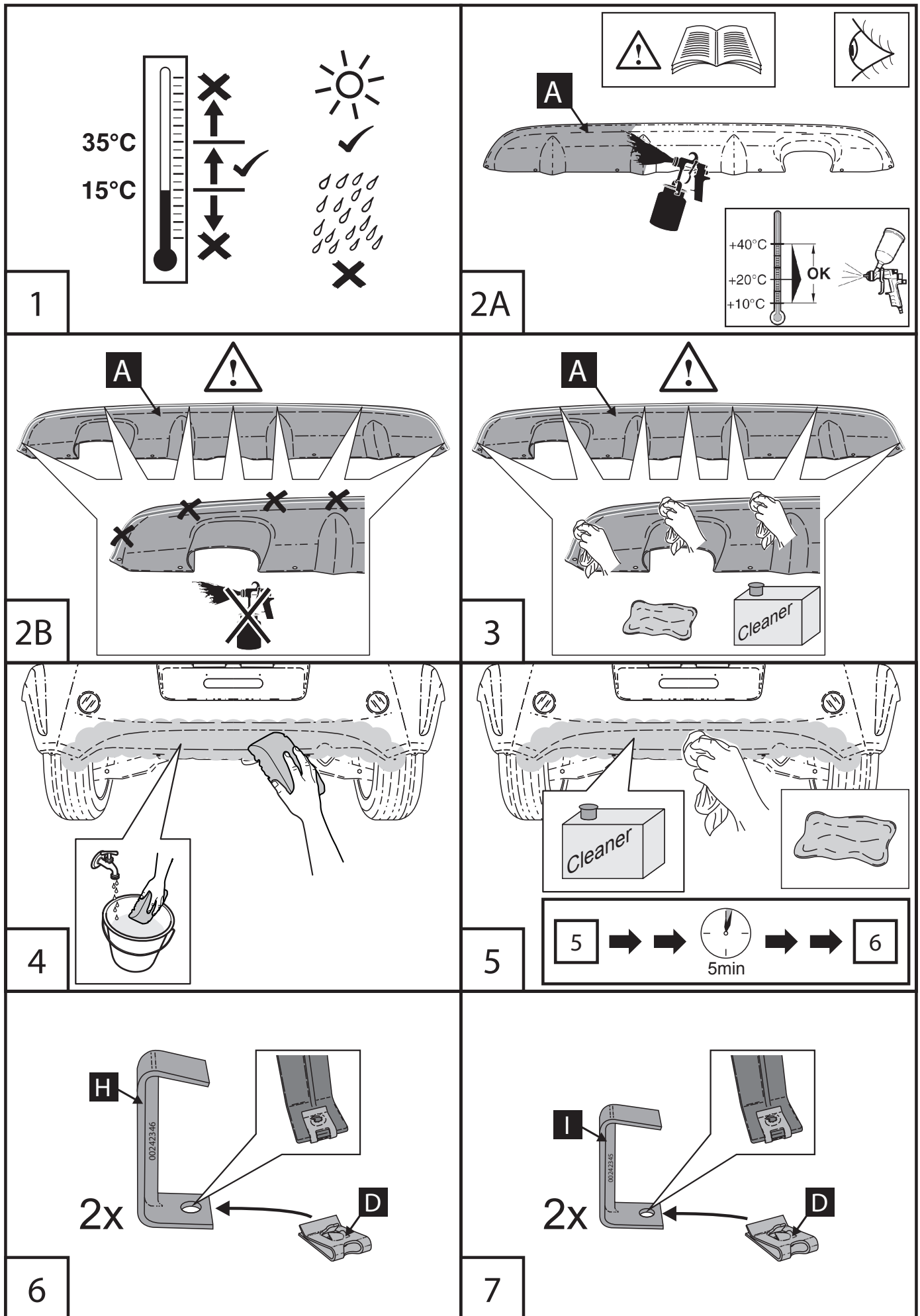

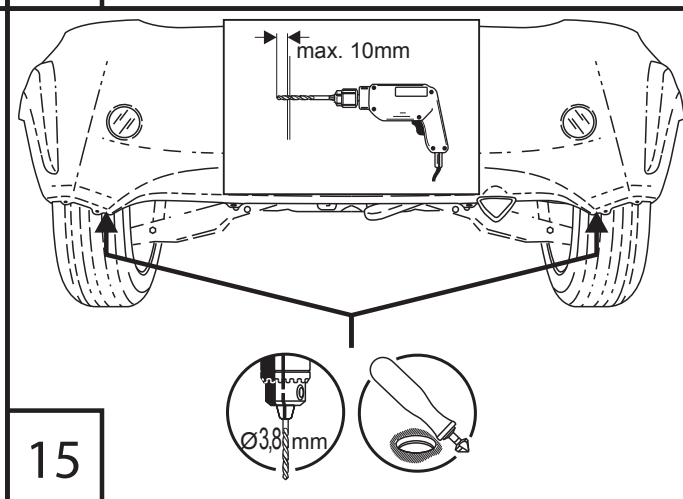
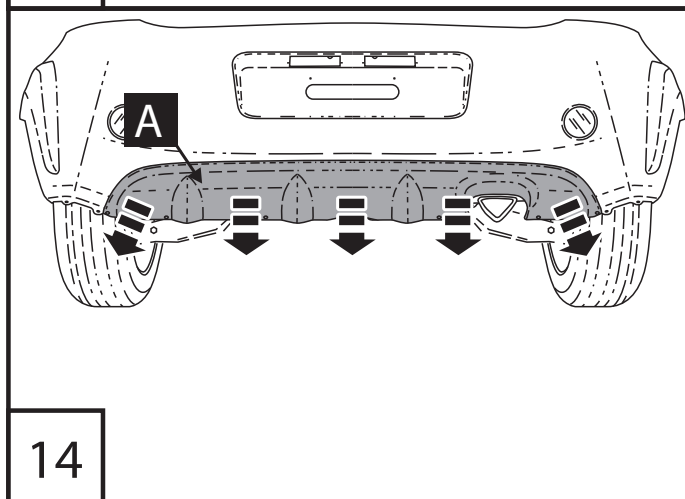
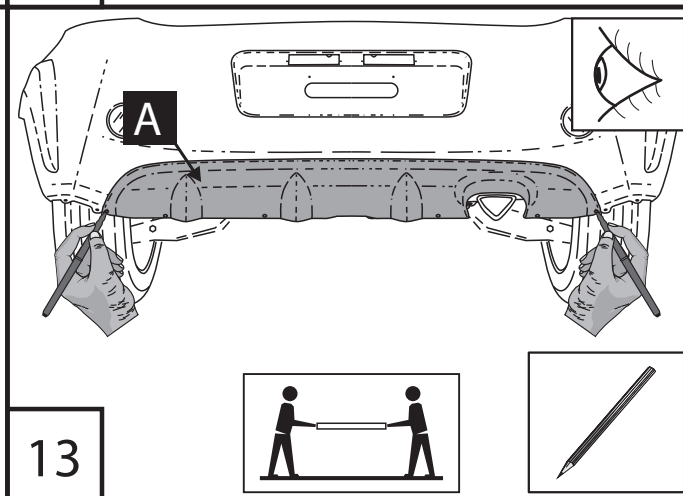
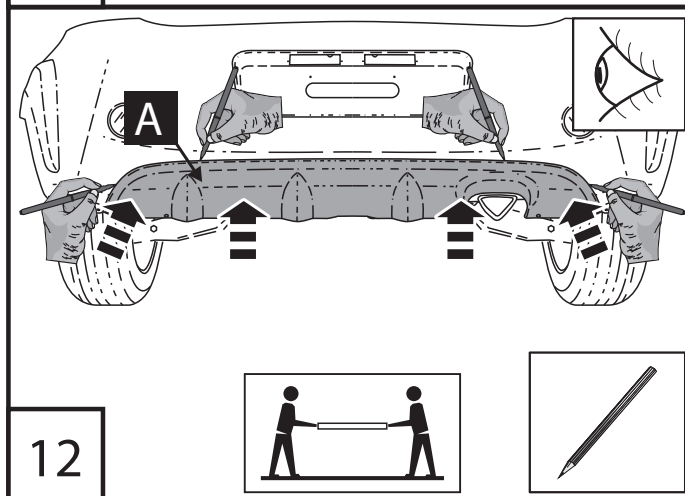
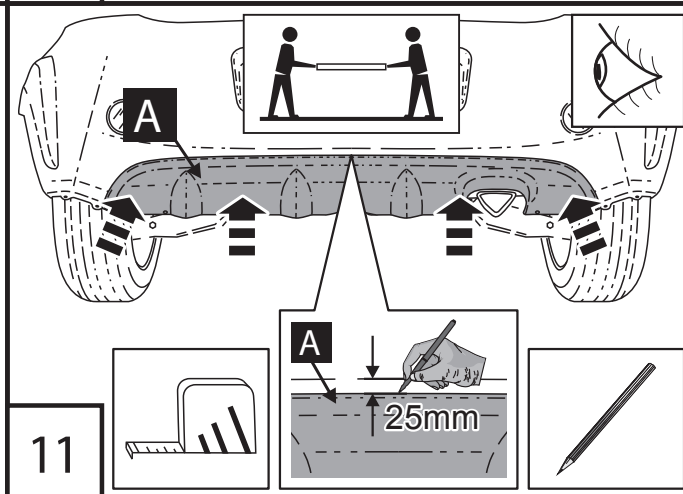
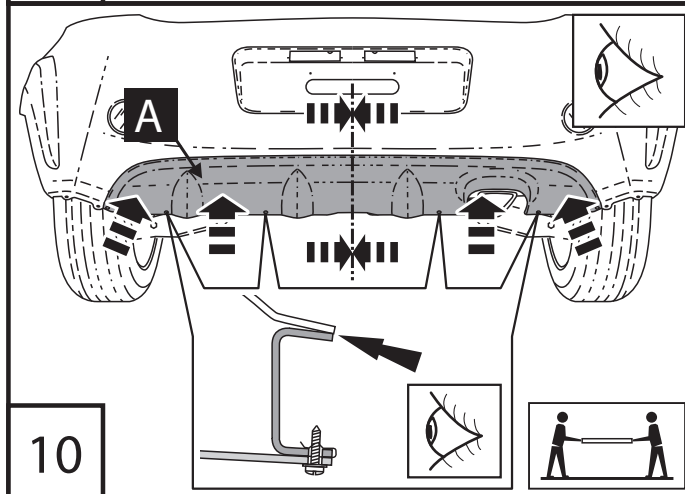
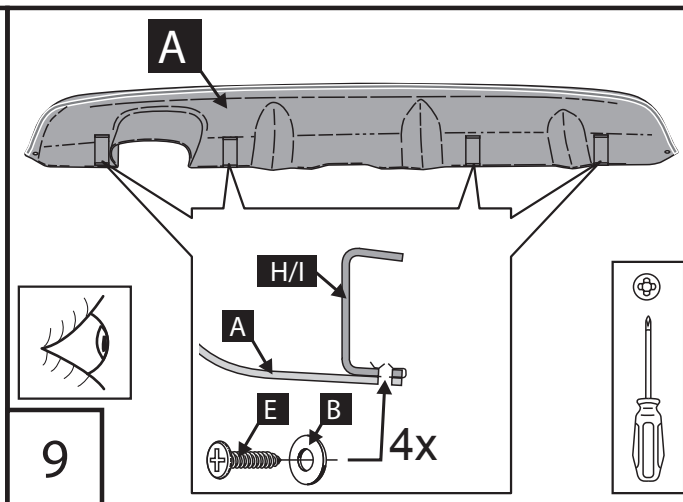
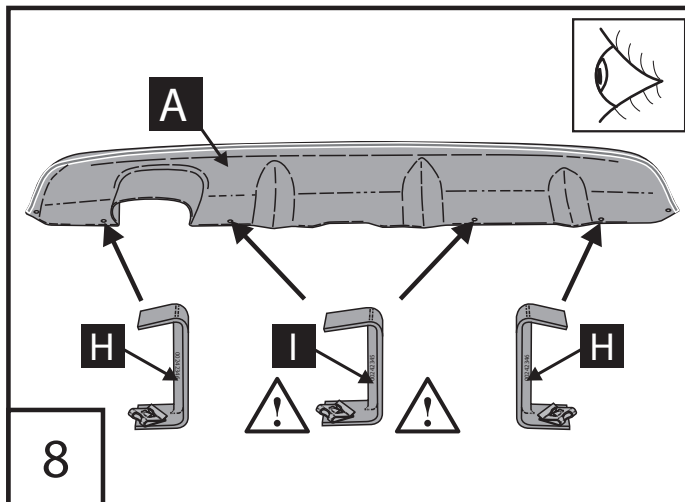

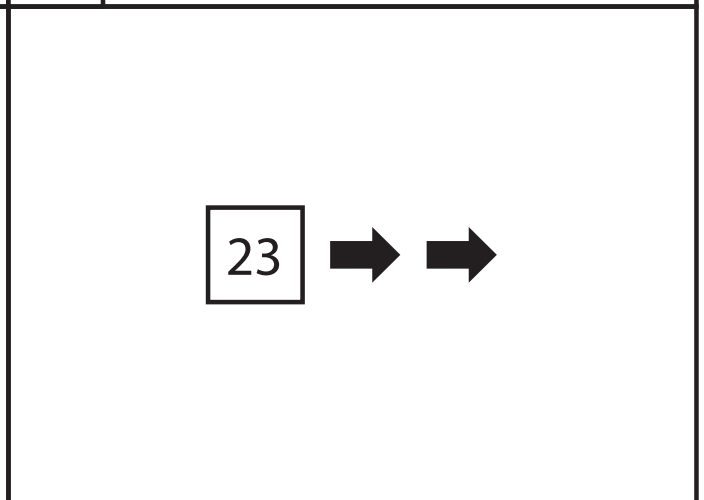
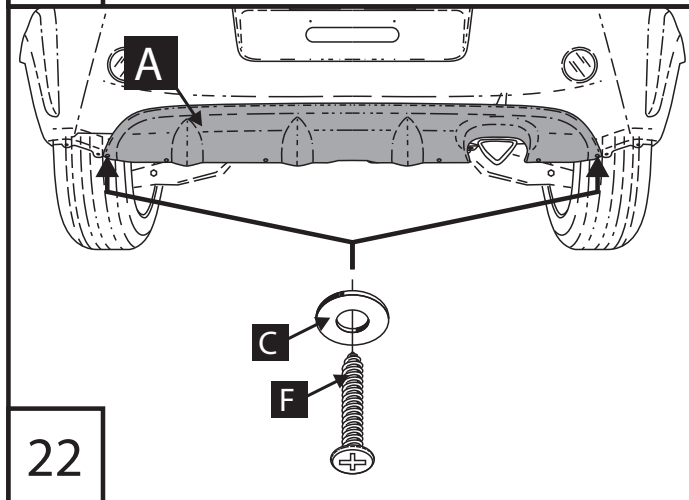
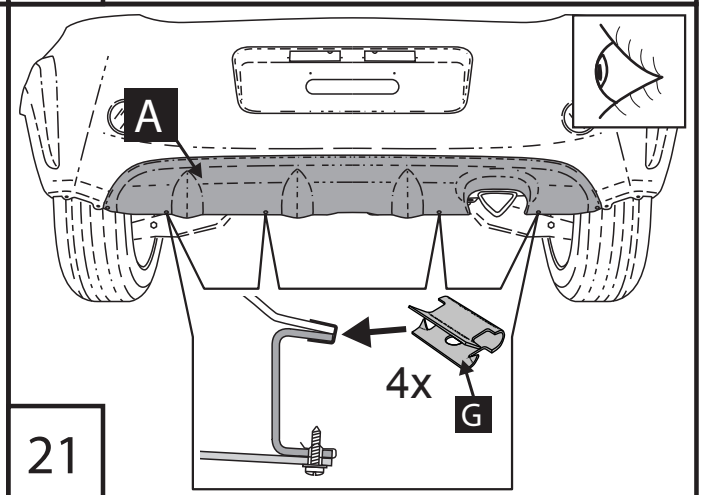
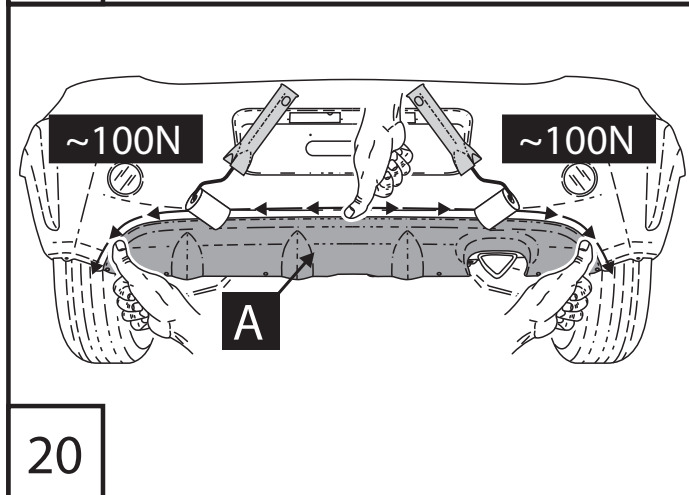
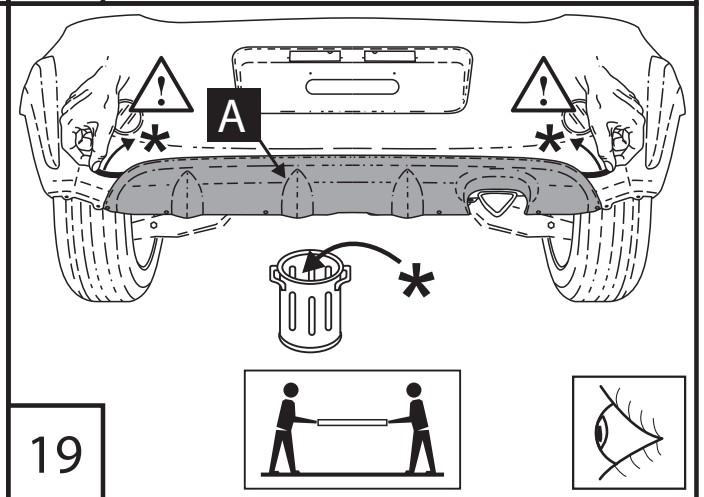
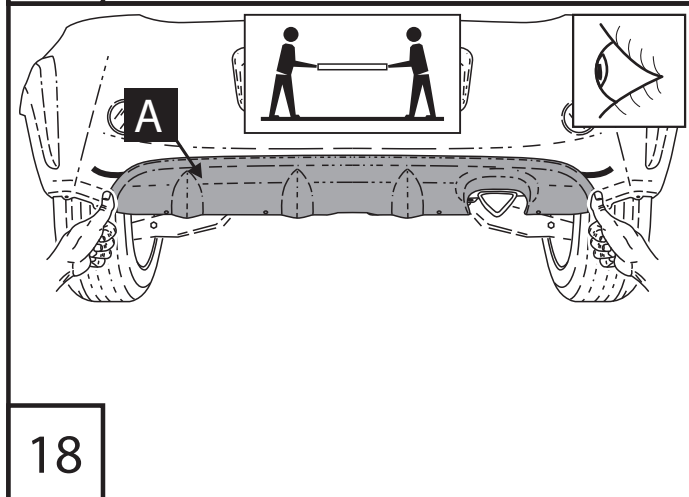
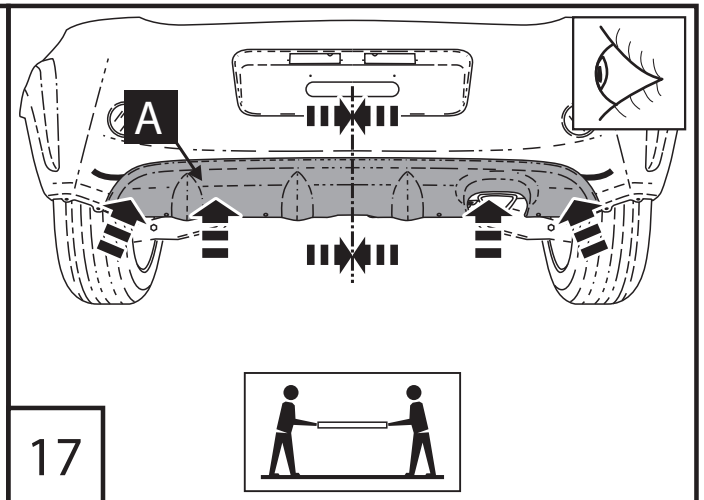
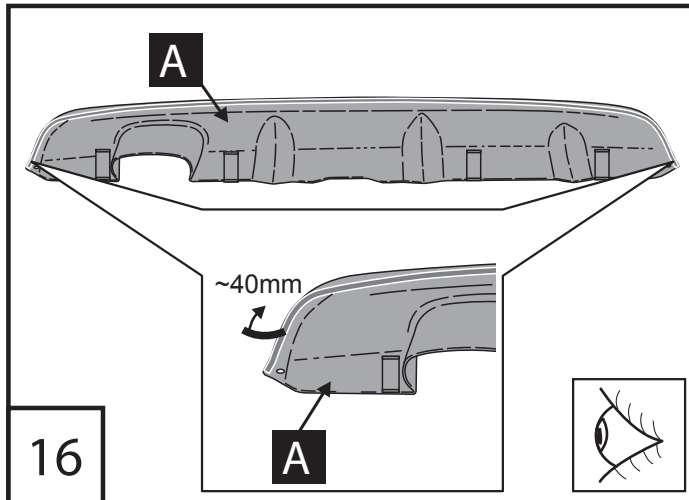

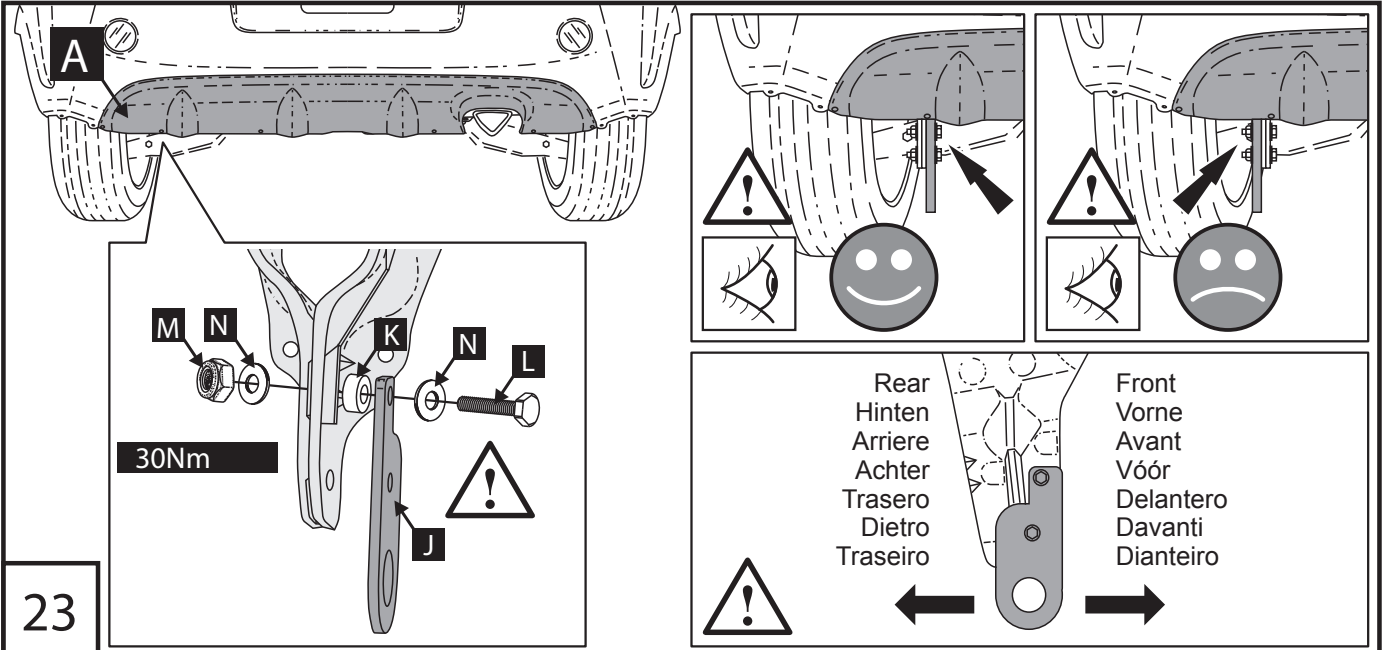

23

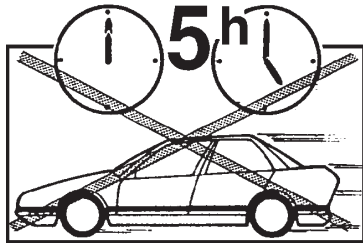

ATTENTION
ACHTUNG
ATTENTION



ATTENCION
ATTENTIE
ATTENZIONE



Nous attirons votre attention sur le fait que toute réclamation ou demande en dommage et intérêt ne pourrait être formulée que tant que le montage aura été fait suivant les instructions techniques prévues pour notre produit. Il est expressément prévu qu' on ne saurait se prévaloir d' un quelconque préjudice contractuel ou réhibitoire si le montage avait été fait en dépit des dites instructions ou dans un garage ne disposant pas des équipements adéquats.

Le type-nr. PZ402-I0640-AB est construit pour le véhicule indiqué ci-dessus et ne peut être monter que sur ce véhicule. Pour la fixation, utiliser exclusivement les éléments ci-joints.



Atención! Pretensiones de garantia respectivamente toda clase de reclamaciones a indemnización por danos y perjuicios pueden considerarse por nosotros solamente en caso de un montaje debidamente ejecutado en un taller especializado. Llamamos expresadamente su atención al hecho que un montaje no apropiado y no efectuado en un taller especializado tendrá por consecuencia la renuncia al ejercicio de toda clase, sobre todo originando del título de ley sobre la responsabilidad para productos defectuosos.

El tipo: PZ402-I0640-AB está construido para el vehículo arriba mencionado y puede montarse exclusivamente sobre este vehículo. Para su fijación se usarán únicamente las piezas de fijación adjuntas.



Achtung! Etwaige Gewährleistungsansprüche bzw. Schadenersatzansprüche aller Art können von uns nur bei einer ordnungsgemäßen und der Anleitung entsprechenden Montage in einer Fachwerkstätte berücksichtigt werden.

Wir weisen ausdrücklich darauf hin, daß eine unsachgemäße und nicht in einer Fachwerkstätte durchgeführte Montage einen Verzicht auf die Geltendmachung jeglicher Art insbesondere auch aus dem Titel des Produkthaftpflichtrechtes bewirkt.

Die Typ-Nr. PZ402-I0640-AB ist für das oben angeführte Fahrzeug konstruiert und darf nur auf diesem Fahrzeug montiert werden.

Für die Befestigung sind ausschließlich die beiliegenden Befestigungsteile zu verwenden.



Attentie! Een claim op garantie, resp. op schadeloosstelling, van welke aard ook, kan door ons slechts worden gehonoreerd indien ons produkt deskundig en overeenkomstig de voorschriften door een vakkundige werkplaats gemonteerd is. Wij wijzen er met nadruk op, dat ondeskundige en niet door een vakkundige werkplaats uitgevoerde montage tot gevolg heeft dat daardoor ieder recht op schadevergoeding, ook op wettelijke aansprakelijkheid inzake producten, vervalt.

Typ-nr. PZ402-I0640-AB is voor het boven genoemde voertuig geconstrueerd en mag alleen op dit voertuig gemonteerd worden.

Voor de bevestiging behoren uitsluitend de bijliggende bevestigingsdelen gebruikt te worden.



Important note! Guarantee claims/compensation claims of all kinds can only be entertained by us if assembly has been carried out properly and in accordance with instructions in a specialist workshop.

We would expressly point out that any improper assembly which is not carried out in a specialist workshop will result in the renunciation of the enforcement of compensation claims of any kind, in particular those arising by virtue of the product liability law.

The typ no.: PZ402-I0640-AB

is constructed for the above vehicle and can only be mounted on said vehicle. For the purpose of fixing, please use the attached fixing parts only.



Attenzione! Qualsiasi diritto a garanzia o diritto al risarcimento del danno può essere preso in considerazione solo in caso di un montaggio eseguito in modo regolare, secondo le rispettive istruzioni, in un'officina specializzata. Si fa notare esplicitamente che, in caso di un montaggio non appropriato, fuori di un'officina specializzata, si rinuncia all'esercizio di qualsiasi diritto, soprattutto di quello derivante dal titolo della responsabilità civile del fabbricante o venditore del prodotto.

Il modell: PZ402-I0640-AB

è stato costruito per il veicolo sopraindicato e può essere montato solo su questo veicolo. Per il fissaggio vanno usati esclusivamente gli elementi di fissaggio acclusi.



Atenção! Quaisquer reivindicações de garantia ou de indemnização apenas poderão ser consideradas por nós se a montagem foi devidamente efectuada numa oficina especializada. Chamamos expressamente a atenção para o facto de que uma montagem não efectuada devidamente e não numa oficina especializada resultará na renúncia do direito a quaisquer reivindicações, em especial á do direito sob a lei da responsabilidade de produtos.

Tipo N° PZ402-I0640-AB

Foi construido para o veiculo acima referido e só poderá ser montado neste veiculo.

Para a fixação, utilizar apenas as peças de fixação juntas.



Painting instructions for primed parts



Grind the primed component smoothly (P800-P1000).
Avoid grinding through the primer.

Check faulty spots, repair them and grind repaired places smoothly (P800-P1000).
Re-prime ground-through spots using a suitable plastic primer.

Thoroughly clean using a silicone remover.

It is important to ensure adequate component support during the process of painting (distortion risk)!
Paint buildup and application technique according to the paint manufacturer; the elasticity-imparting additives specified by the paint manufacturer are particularly important.
The material designation is visible in the interior of the component (>.....<, z.B. >PUR-MF15<).

No stoving of the paint (maximum 40°C)!



Lackieranleitung für grundierete Teile



Grundiertes Bauteil anschleifen (P800-P1000).
Durchschleifen der Grundierung vermeiden.

Auf Fehlerstellen prüfen und ausbessern sowie Reparaturstellen anschleifen (P800-P1000).
Durchschleifstellen mit geeigneter Kunststoffgrundierung nachgrundieren.

Gründlich mit Silikonentferner reinigen.

Auf ausreichende Bauteilunterstützung während des Lackierprozesses ist zu achten (Verzugsgefahr)!
Lackaufbau und Applikationstechnik nach Lackhersteller, auf die vom Lackhersteller vorgegebenen Elastikzusätze ist besonders zu achten.
Die Materialbezeichnung ist auf der Bauteilinnenseite (>.....<, z.B. >PUR-MF15<) ersichtlich.

Kein Einbrennlackieren (max. 40°C)!



Instruction de vernissage pour pièces apprêtées



Poncer le composant apprêté (P800-P1000).
Eviter une usure de la couche d'apprêt.

Contrôler les emplacements défectueux et retoucher, poncer les emplacements de réparation (P800-P1000).
Retoucher les emplacements usés par le ponçage avec un apprêt acrylique approprié.

Bien nettoyer avec un produit anti-silicones.

Veiller à bien soutenir le composant pendant le laquage (risque de déformation)!
Respecter les instructions du fabricant de laque pour la composition et l'application de celle-ci, y compris les additifs plastifiants prescrits.
Le code de matériau figure sur le côté intérieur du composant (>.....<, p. ex. >PUR-MF15<).

Pas de laquage avec cuisson (max. 40°C) !



Introduzione verniciatura per parti impregnate



Rettificare l'elemento dotato di mano di fondo (P800-P1000).
Evitare che la mano di fondo sia asportata.

Controllare l'eventuale presenza di punti difettosi e riparare, rettificare i punti di riparazione (P800-P1000).
Riapplicare un'adeguata mano di fondo in materiale sintetico sui punti in cui la mano di fondo è stata asportata.

Pulire accuratamente con prodotto per eliminare il silicone.

Occorre assicurare un sufficiente supporto dell'elemento durante il processo di verniciatura (pericolo di distorsione)!
Struttura della vernice e tecnica di applicazione secondo il produttore della vernice, occorre osservare particolarmente gli additivi elastici prescritti dal produttore della vernice.
La designazione del materiale è riportata sul lato interno dell'elemento (>.....<, p.es. >PUR-MF15<).

Nessuna verniciatura a fuoco (max. 40°C)!

NL**Lakinstructie voor onderdelen in grondverf**

Gegroundverfd component licht schuren (P800-P1000).
Doorschuren van de grondlaag vermijden.

Op onvolkomenheden controleren en herstellen alsook de gerepareerde plekken licht schuren (P800-P1000).
Doorgesuurde plekken met een geschikte kunststofgrondlaag nagronden.

Met siliconenverwijderaar grondig reinigen.

Let tijdens het lakken op een toereikende ondersteuning van de componenten (ivm vervorming)!
Lakproces en applicatietechniek volgens de voorschriften van de lakfabrikant. Bijzondere aandacht is vereist voor de voorgeschreven toevoegingen t.b.v. de elasticiteit
De materiaalbenaming bevindt zich aan de binnenkant van de component (>.....<, b.v. >PUR-MF15<)

Niet moffellakken (max. 40°C)!

E**Instrucciones de Pintura para piezas con la primera capa**

Lijar ligeramente la pieza imprimada (P800-P1000).
Al lijar, no atravesar la imprimación.

Examinar con respecto a partes defectuosas y retocar, así como lijar ligeramente las partes a reparar (P800-P1000).
Reimprimir las partes atravesadas con una imprimación sintética adecuada.

Limpiar minuciosamente con quitasilicona.

Tener cuidado de apoyar suficientemente la pieza durante el proceso de lacado (¡peligro de deformación!).
Estructura de la laca y técnica de aplicación según el fabricante de lacas. Tener cuidado especial de los aditivos elásticos prescritos por el fabricante de lacas.
La designación del material puede verse en la parte interior de la pieza (>.....<, p. ej. >PUR-MF15<).

¡No lacado al fuego (max. 40°C)!

P**Instruções de Pintura para peças com a primeira demão**

Lixar o componente com primeira demão (P800-P1000).
Evitar o lixamento completo da primeira demão.

Verificar pontos de falha e retocar, assim como lixar os pontos de reparação (P800-P1000).
Passar uma primeira demão nos pontos que foram lixados por completo com pintura de fundo de material plástico.

Limpar a fundo com removedor de silicone.

Prestar atenção para um suporte suficiente do componente durante o processo de pintura (perigo de estiramento)!
Estruturação do verniz e técnica de aplicação conforme o fabricante do verniz, observar especialmente os aditivos elásticos prescritos pelo fabricante do verniz.
A designação do material se encontra no lado interno do componente (>.....<, p. ex. >PUR-MF15<).

Não é verniz que tenha de sofrer cozimento (máx. 40°C)!