

32

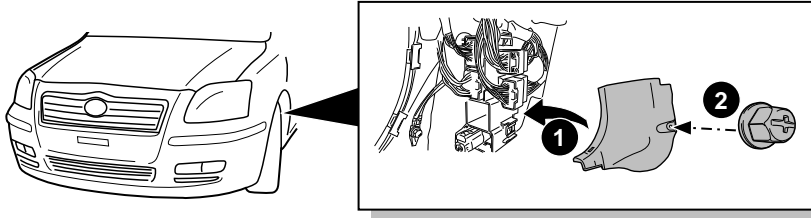

33

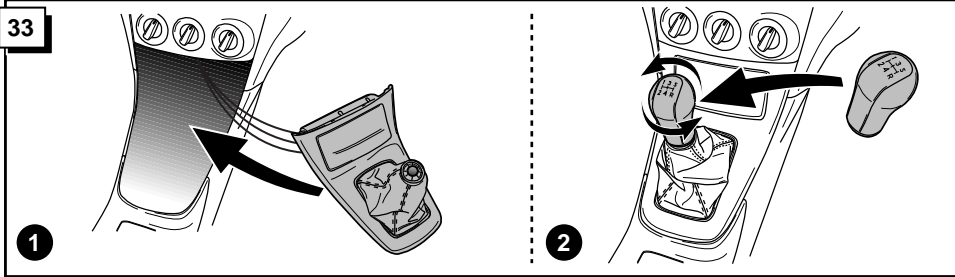

34

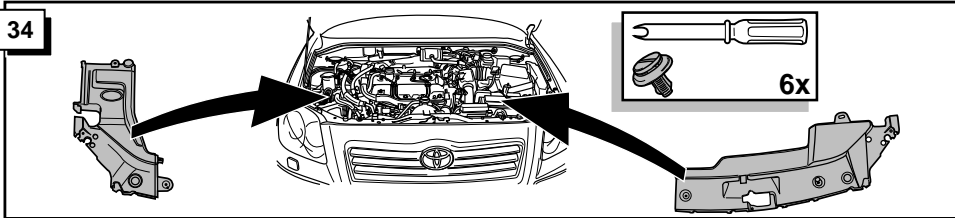

35

LHD

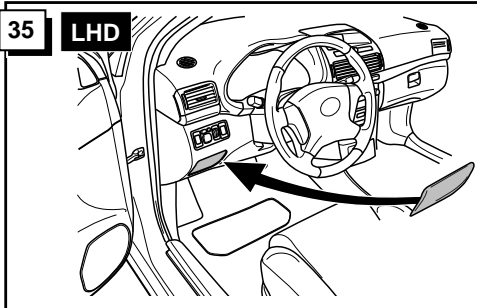

36

RHD

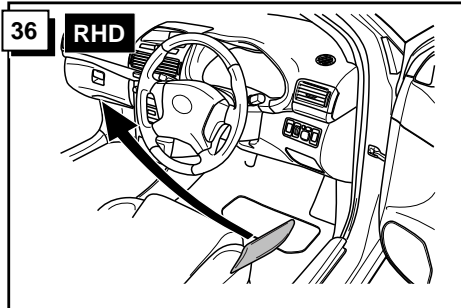

37

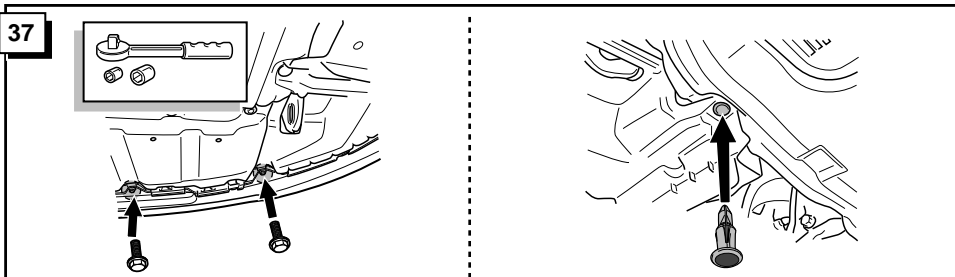

Vehicle  
**Avensis**

Application  
**2003-**

PARTNUMBER :

**PZ417-T0513-00**

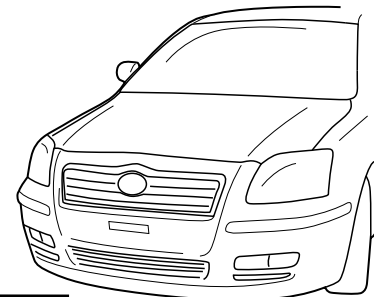

**Front foglamp kit**  
**Nebelscheinwerfer**  
**Mistlampenset**  
**Feux antibrouillard**

**KIT CONTENT - STÜCKLISTE - KIT INHOUD - CONTENU**

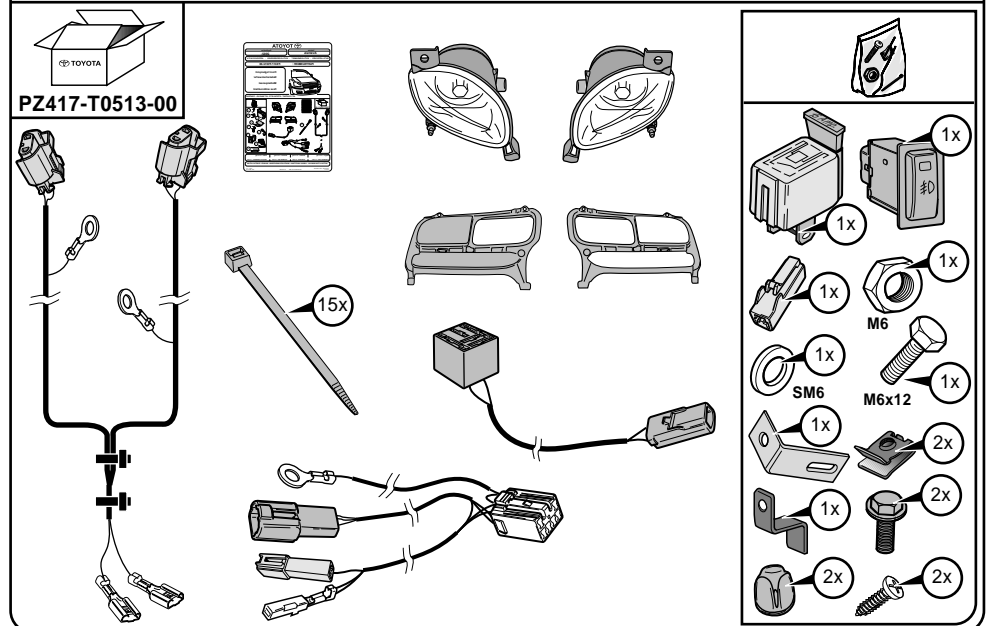

Weight : 2,24 kg

Gewicht : 2,24 kg

Gewicht : 2,24 kg

Poids : 2,24 kg

Installation time : 50 min.

Anbauzeit : 50 min.

Installatie tijd : 50 min.

Temps d' installation : 50 min.

**INSTALLATION MANUAL - ANBAU ANLEITUNG - MONTAGE HANDLEIDING - MANUEL D'INSTALLATION**

**PARTNAME :** Front foglamp set / Nebelscheinwerfer  
Mistlampenset / Feux antibrouillard

**PARTNUMBER :** PZ417-T0513-00

**APPLICATION - ANWENDUNG - APPLICATIE - APPLICATION**

**Avensis 2003-: \*DT25\*\*-A\*\*E\*W**

| VEHICLE OPTION - FAHRZEUG OPTION - VOERTUIG OPTIE - OPTION VEHICULE                         |   |
|---|---|
| Not applicable<br>Nicht zutreffend<br>Niet van toepassing<br>Non applicable                 | Not applicable<br>Nicht zutreffend<br>Niet van toepassing<br>Non applicable |
| ACCESSORY - ZUBEHÖR - ACCESSOIRE- ACCESSOIRE  |   |
| Not applicable<br>Nicht zutreffend<br>Niet van toepassing<br>Non applicable                 | Not applicable<br>Nicht zutreffend<br>Niet van toepassing<br>Non applicable |
| SAFETY PRECAUTION - SICHERHEITSMÄßNAHME - VEILIGHEIDSVORSCHRIFTEN - PRECAUTIONS DE SECURITE |   |
| Not applicable<br>Nicht zutreffend<br>Niet van toepassing<br>Non applicable                 |   |

**TOOLS - WERKZEUGE - WERKTUIGEN - OUTILS**

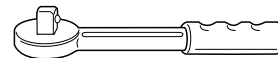
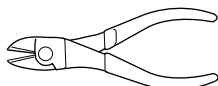
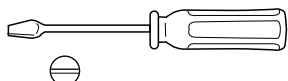
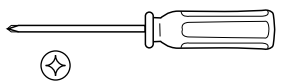

10mm



12mm

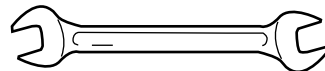

10mm

12mm



**26**

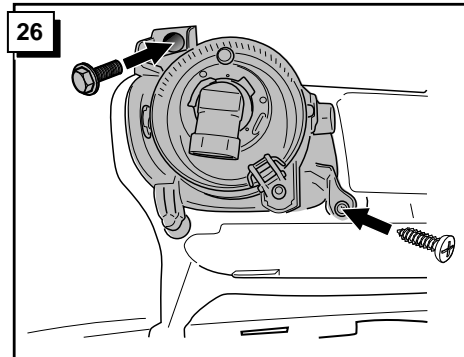

**27**

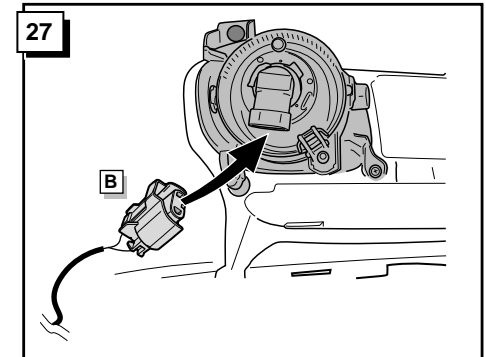

**28**

- \*\* Repeat fig. 18 up to 27 for the right foglamp.
- \*\* Fig. 18 bis 27 für den rechter Nebelscheinwerfer wiederholen.
- \*\* Herhaal fig. 18 t/m 27 voor de rechter mistlamp.
- \*\* Répétez les fig. 18 à 27 pour le feu de brouillard a droite

**29**

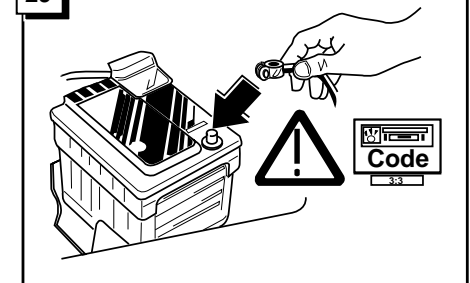

**30**

**! CHECK FUNCTIONS !  
FUNKTIONEN KONTROLLIEREN !  
CONTROLEER FUNCTIES !  
CONTRÔLER LES FONCTIONS !**

**31**

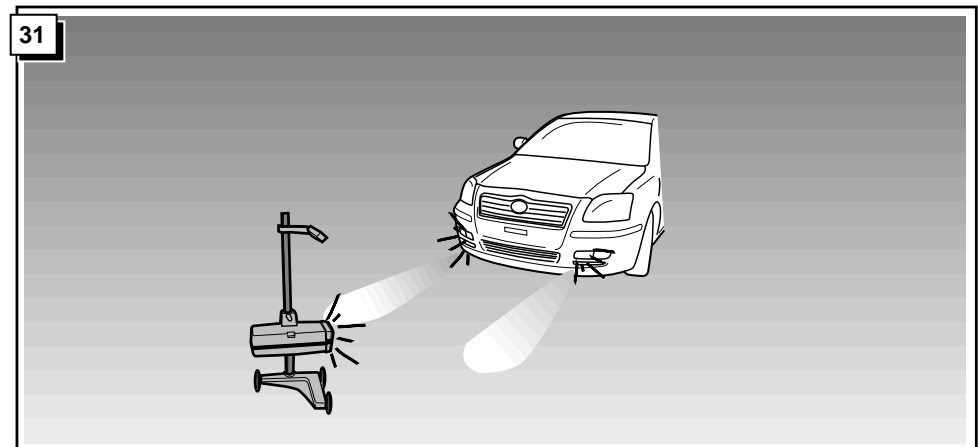

19

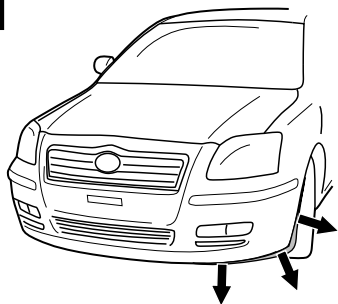

20

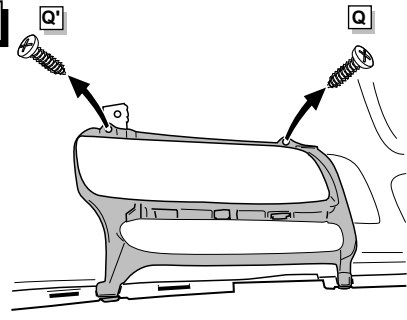

21

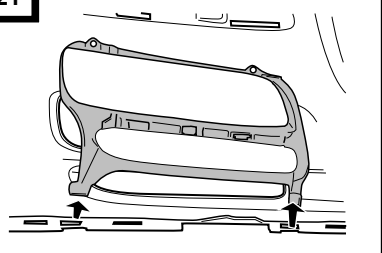

22

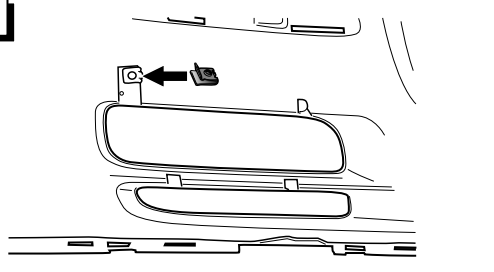

23

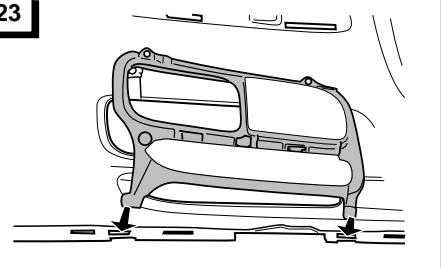

24

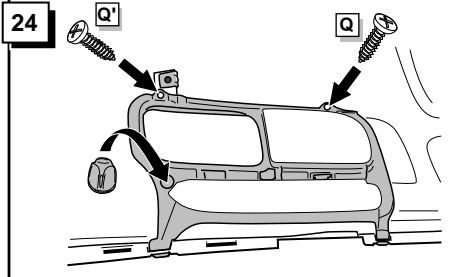

25

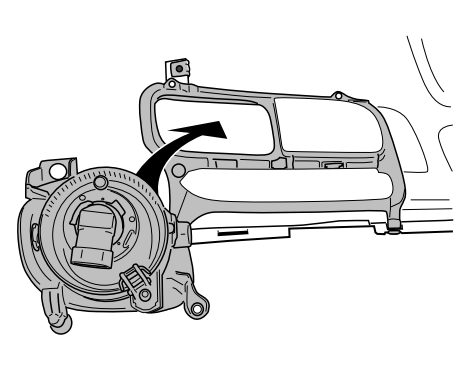
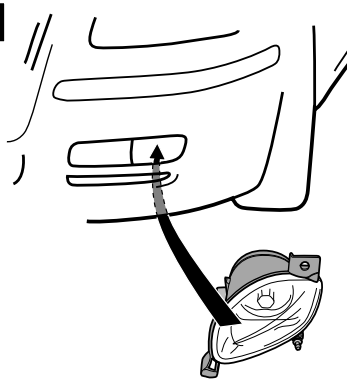

\*Number of installation steps : 37

\*Zahl der Einbauschritte: 37

\*Aantal installatie stappen: 37

\*Nombre des démarches d'installation: 37

CRITICAL OPERATIONS - SICHERHEITSMABNAHME - KRITIEKE HANDELINGEN - OPERATIONS DÉLICATE

Picture:

Abbildung:

Figuur:

Illustration:

#### ATTENTION - LET OP - ACHTUNG - ATTENTION

- The use of front foglamps in traffic situations is subject to the local regulations.
- Die Benutzung der Nebelscheinwerfers richtet sich nach den örtlichen Bestimmungen.
- Het gebruik van mistlampen is onderhevig aan plaatselijke verkeersregels.
- L'utilisation des feux antibrouillard est soumise a des réglementations locales

\* Modifications of spanner jaw size for hexagonal bolts and nuts according to ISO 272 (1990). Please check the respective widths and only use the correct tools.

\* Umstellung der Schlüsselweiten von Sechskantschrauben und Muttern nach ISO 272 (1990). Bitte prüfen Sie die jeweilige Schlüsselweite und verwenden Sie nur das hierzu passende Werkzeug.

\* Omzetting van de sleutelwijdten voor zes-kantschroeven en moeren volgens ISO 272 (1990). Controleert U a.u.b. elke sleutelwijdte en gebruik alleen het hiervoor bestemde gereedschap.

\* Modification de la taille des clefs pour les boulons et écroux hexagonaux conformément a ISO 272 (1990). Veuillez contrôler la largeur respective des clefs et n' employez qu' un outillage approprié.

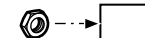

unscrew  
losdrehen  
losdraaien  
desserrer



tighten  
festdrehen  
vastdraaien  
serrer

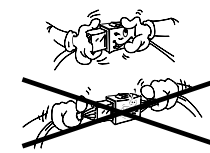
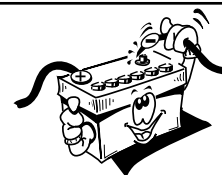

1

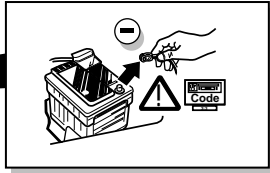
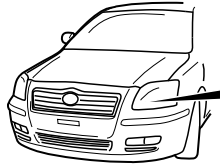

INFO

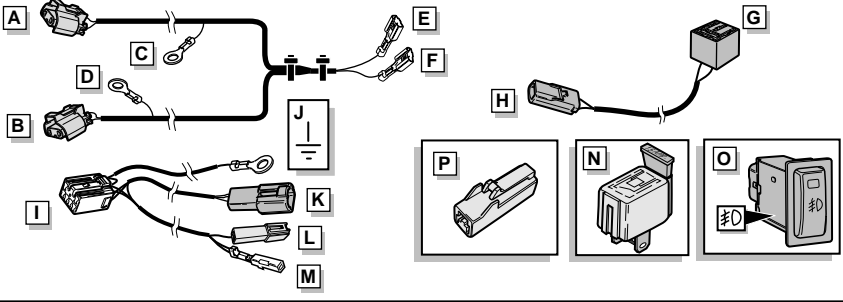

ROUTING LHD

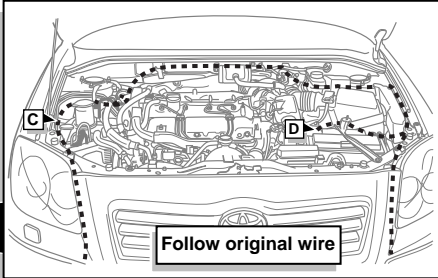
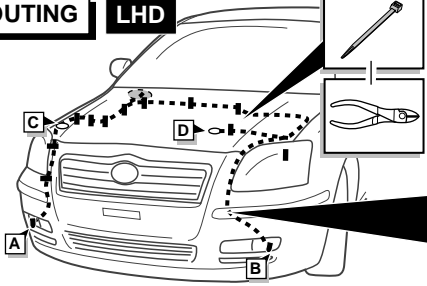

Follow original wire

ROUTING RHD

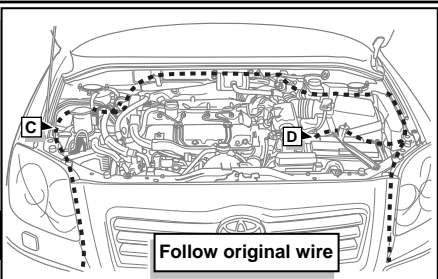
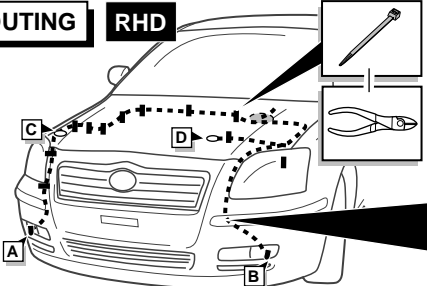

Follow original wire

2

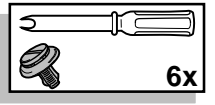
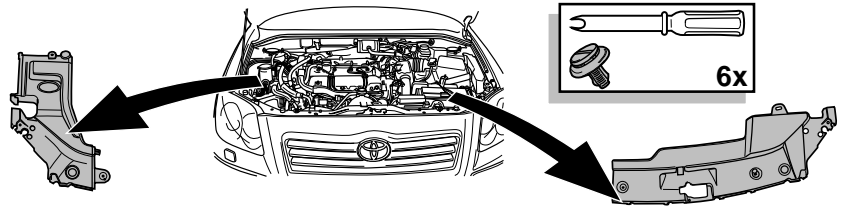

ROUTING RHD

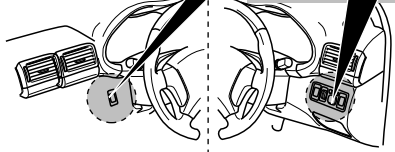
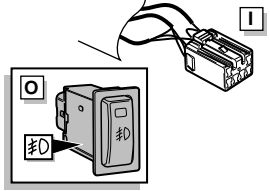

Check for free positions  
Suchen Sie die verfügbaren positionen  
Zoek vrije posities  
Cherchez les positions disponibles

15

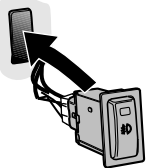
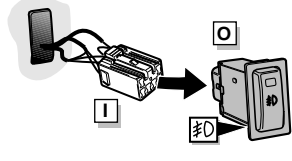
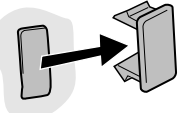

16

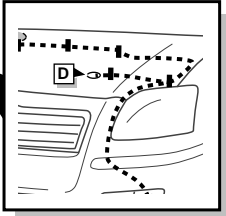
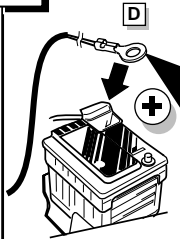

17

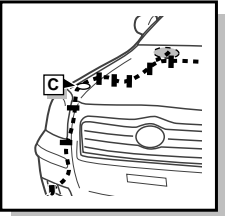
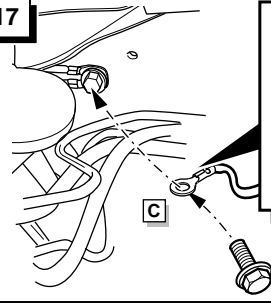

18

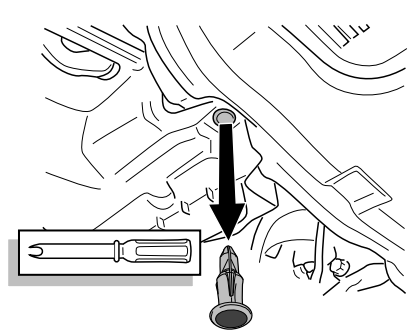
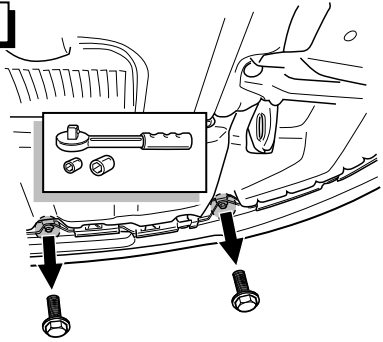

11

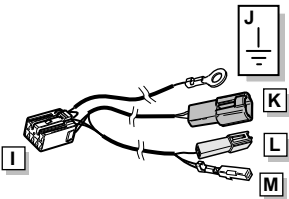

12

LHD

RHD

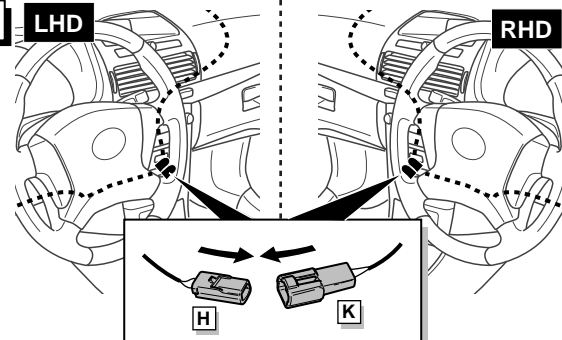

13

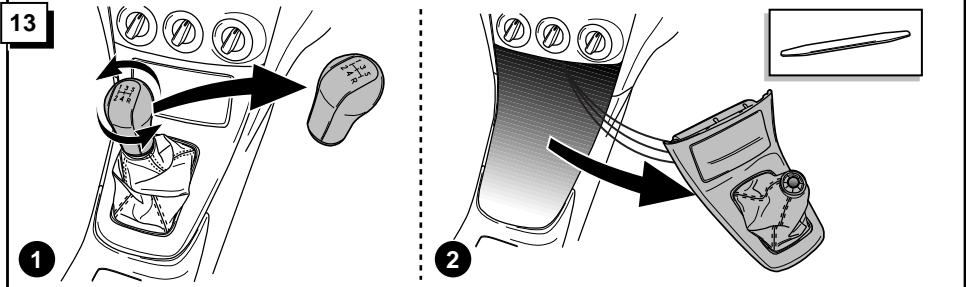

14

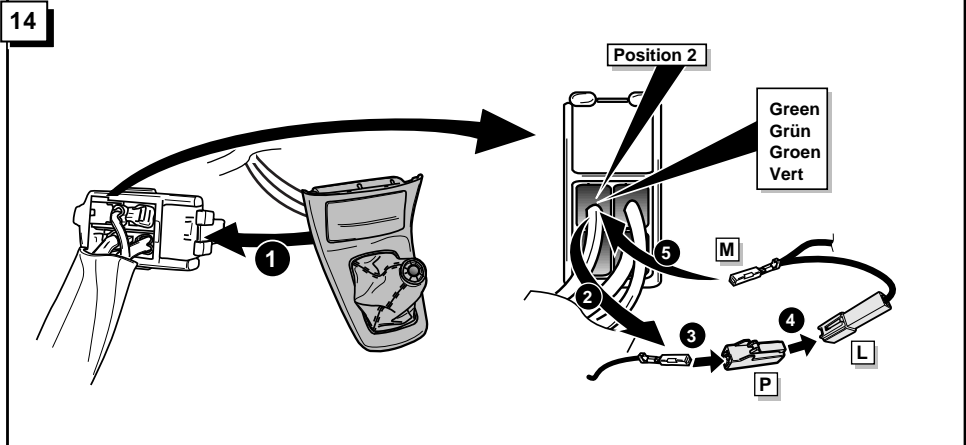

ROUTING LHD

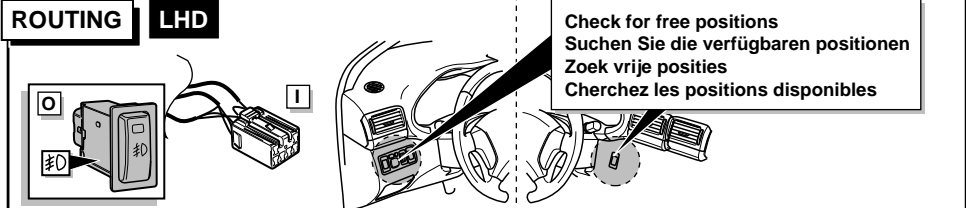

Check for free positions  
Suchen Sie die verfügbaren positionen  
Zoek vrije posities  
Cherchez les positions disponibles

3

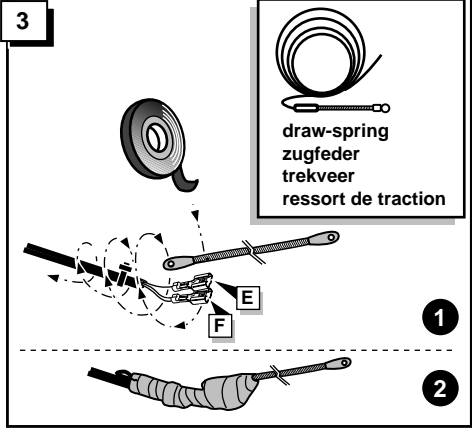

4

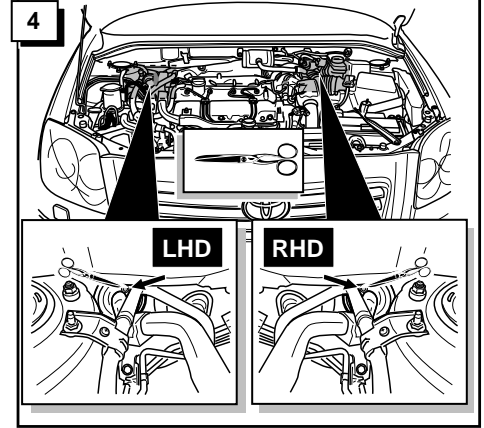

ROUTING LHD

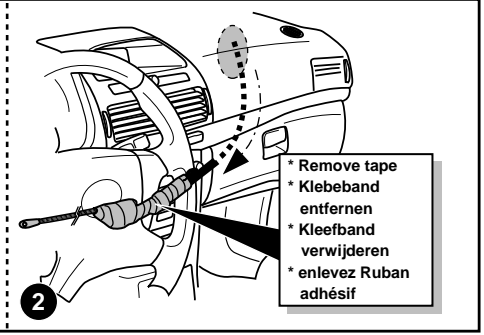
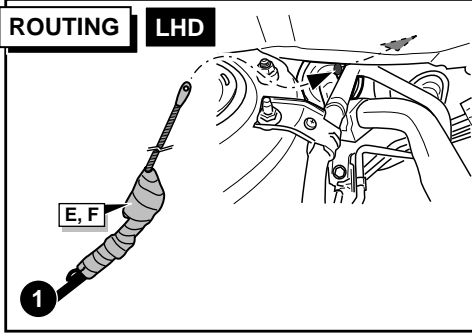

\* Remove tape  
\* Klebeband entfernen  
\* Kleefband verwijderen  
\* enlevez Ruban adhésif

ROUTING RHD

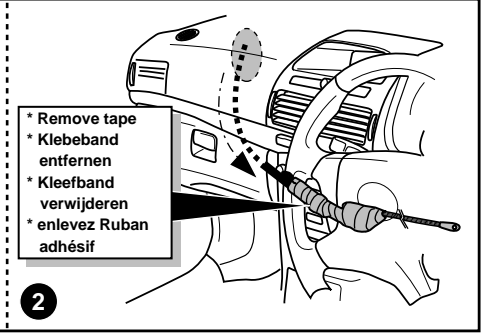
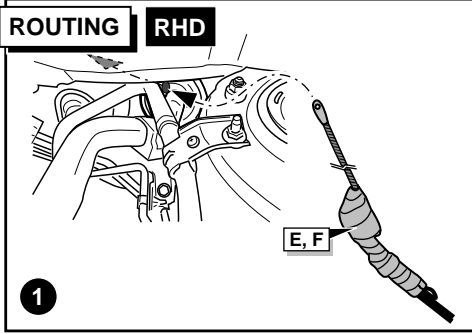

\* Remove tape  
\* Klebeband entfernen  
\* Kleefband verwijderen  
\* enlevez Ruban adhésif

5

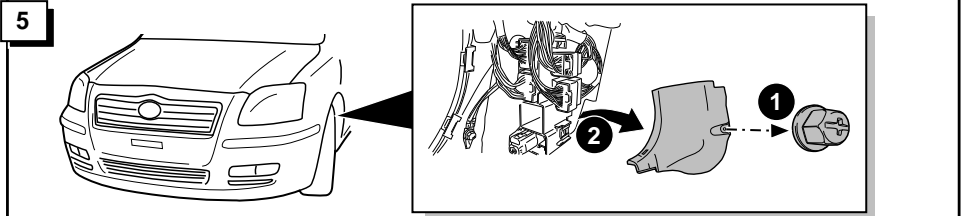

**ROUTING LHD**

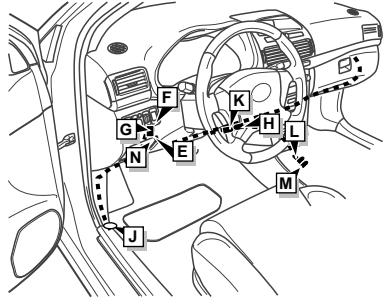

**RHD**

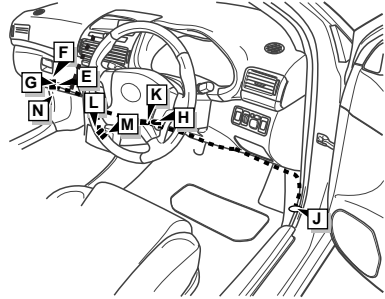

**6 LHD**

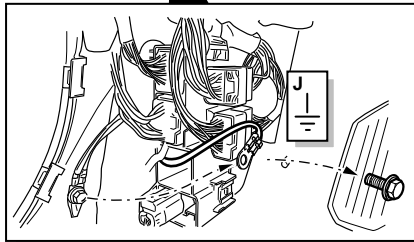
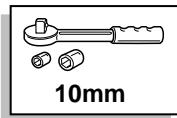
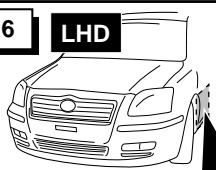

**RHD**

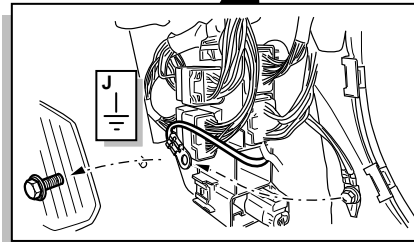
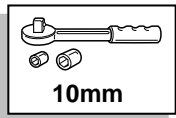
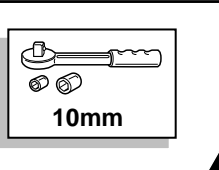

**7**

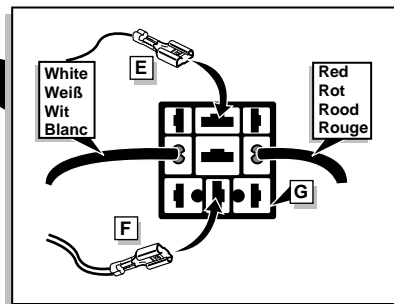
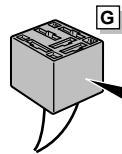

**8 LHD**

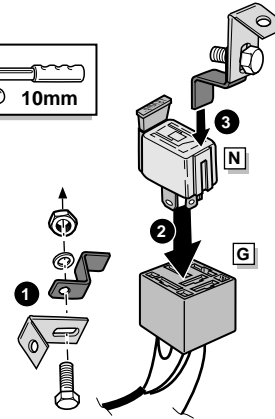
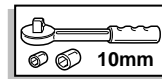
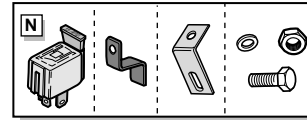

**RHD**

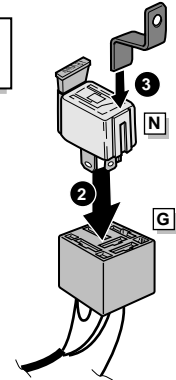
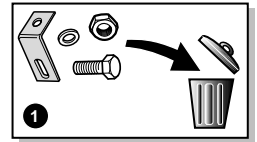
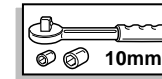
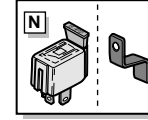

**9 LHD**

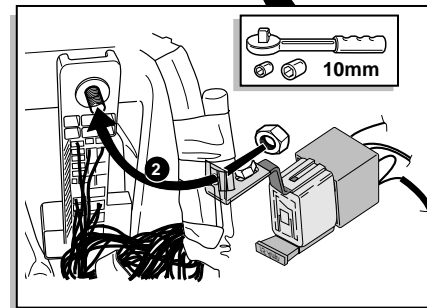
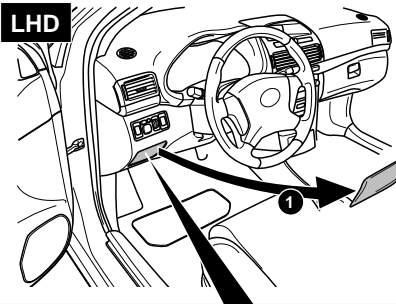

**10 RHD**

