

# BARRACUDA BICYCLE HOLDER

MONTAGEANLEITUNG - INSTRUCTIONS DE MONTAGE - FITTING INSTRUCTIONS

ASENNUSOHJEET - MONTERINGSANVISNING - MONTAGEVOORSCHRIFT

INSTRUCCIONES DE MONTAJE - INSTRUZIONI DI MONTAGGIO

Part number PZ4AF-99647-00

Part number PZ4AF-99647-01

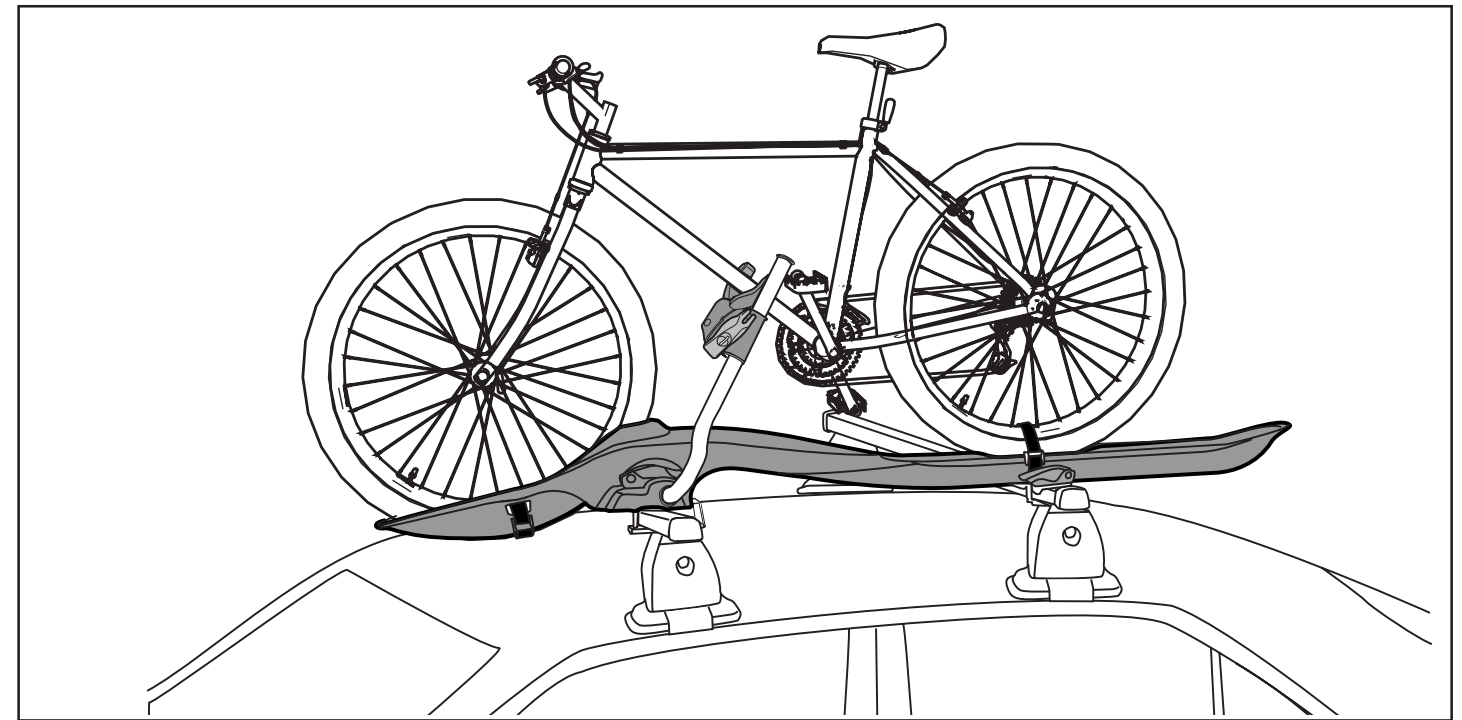

AIM No: 001 349 - 0

According to DIN 75302

0811 151068-2

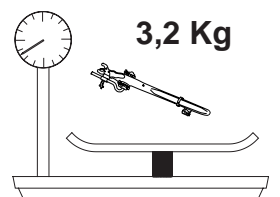

Inhalt  
 Contents  
 Innehåll  
 Content  
 Inhoud  
 Sisältö  
 Contenido

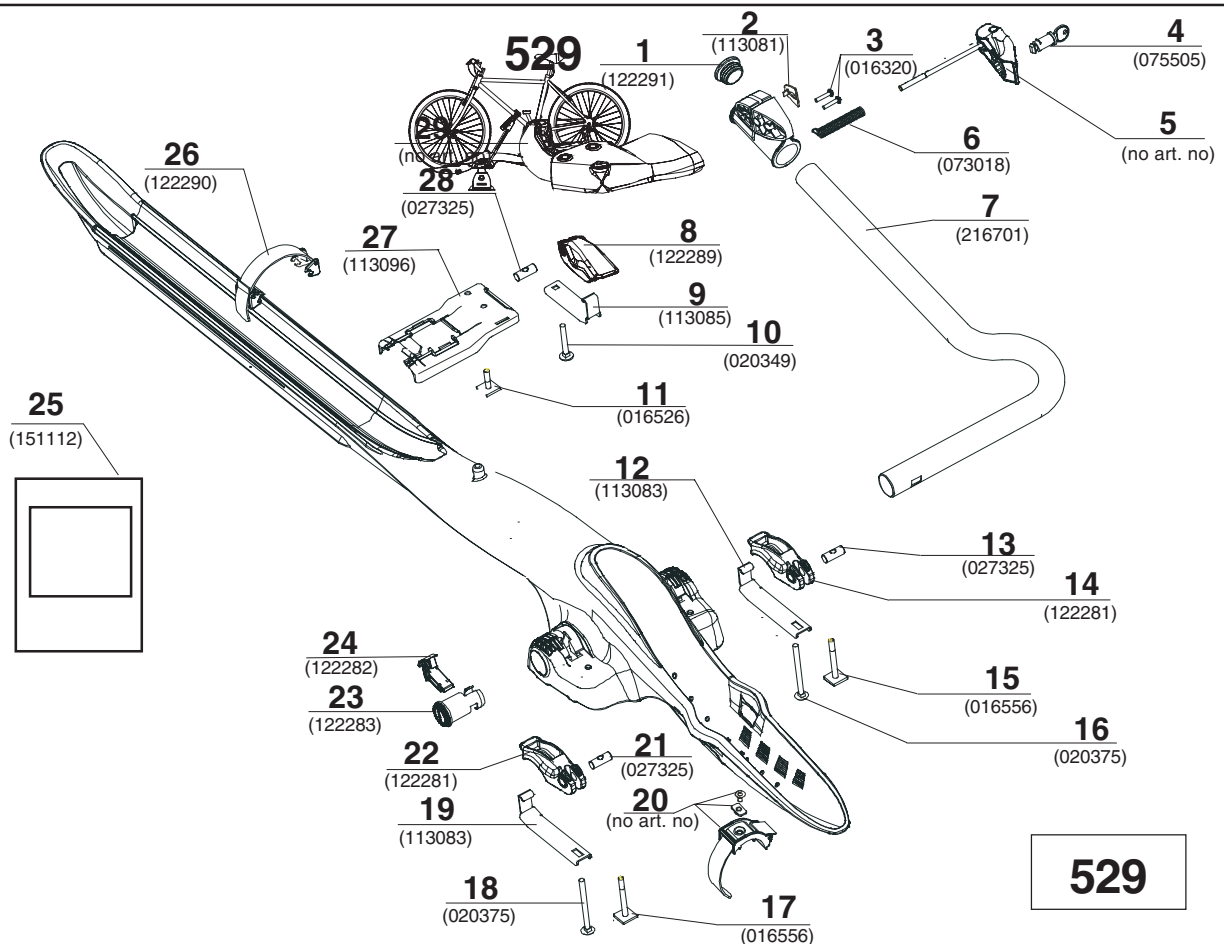
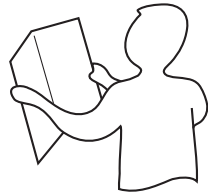
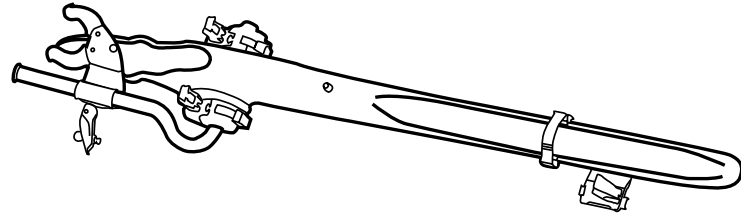
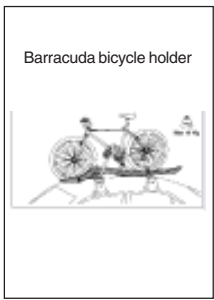
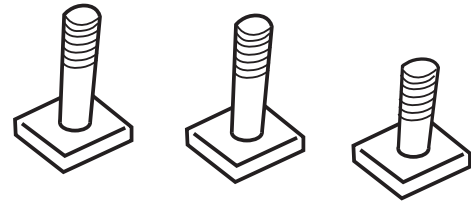
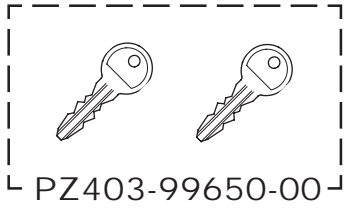



Important  
Wichtig

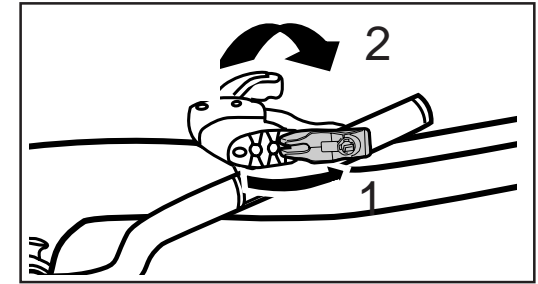

1

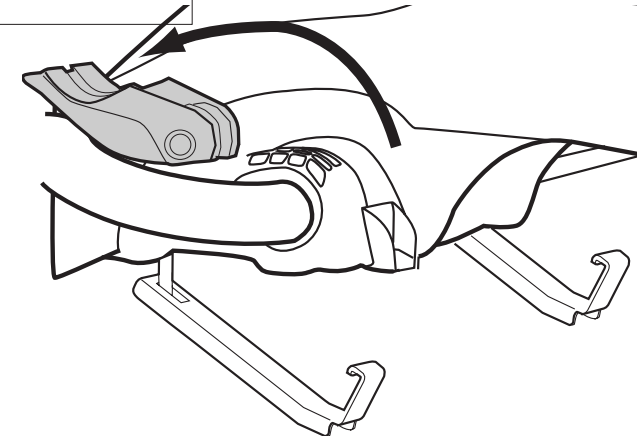
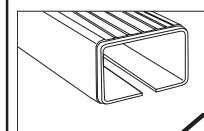
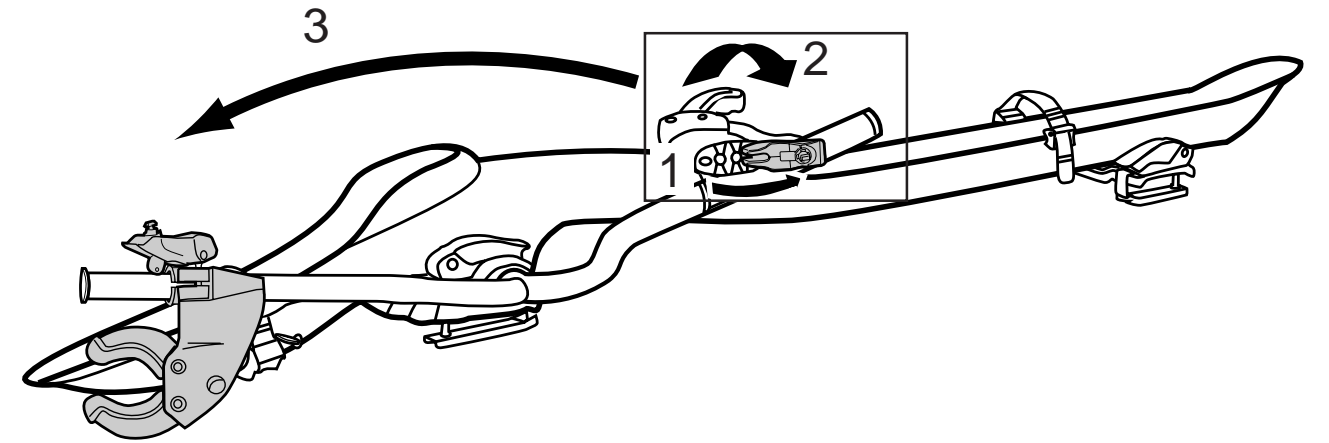

x3

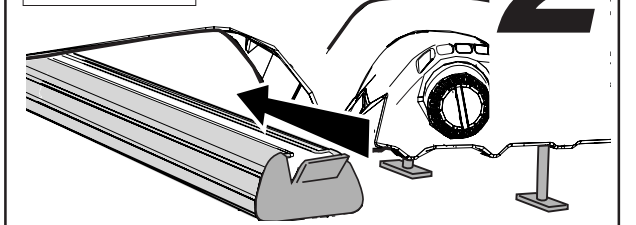
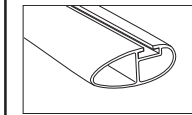

2

Standard

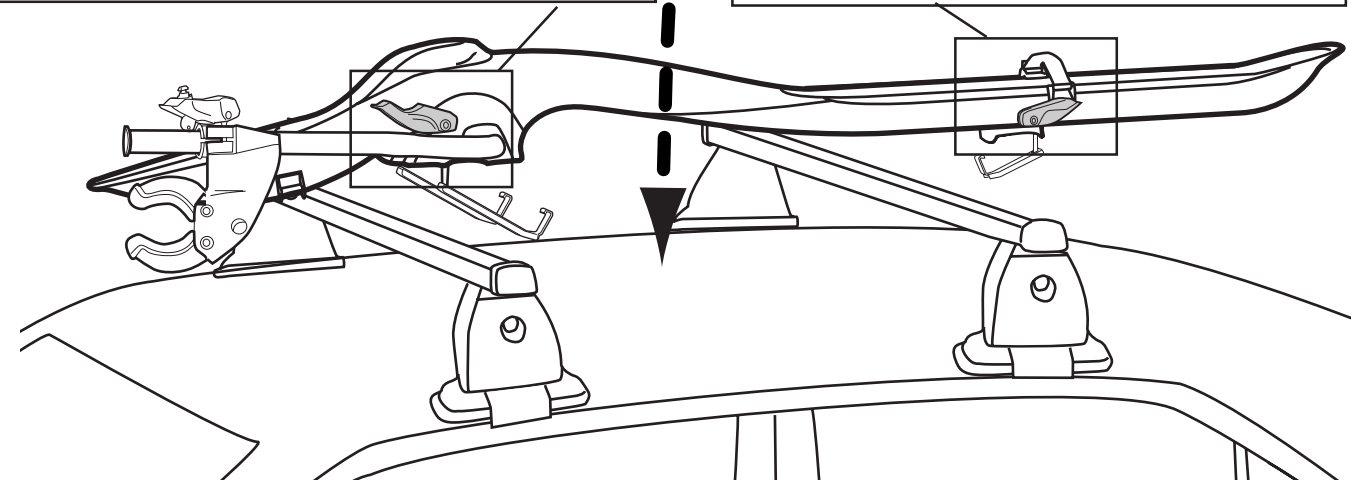
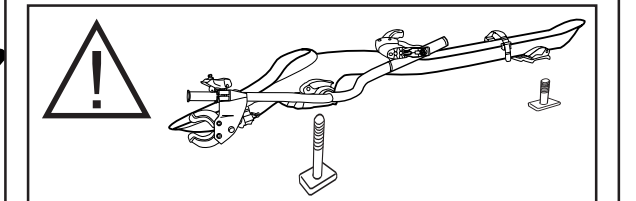
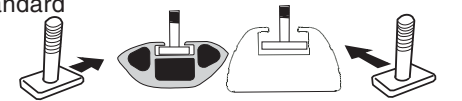

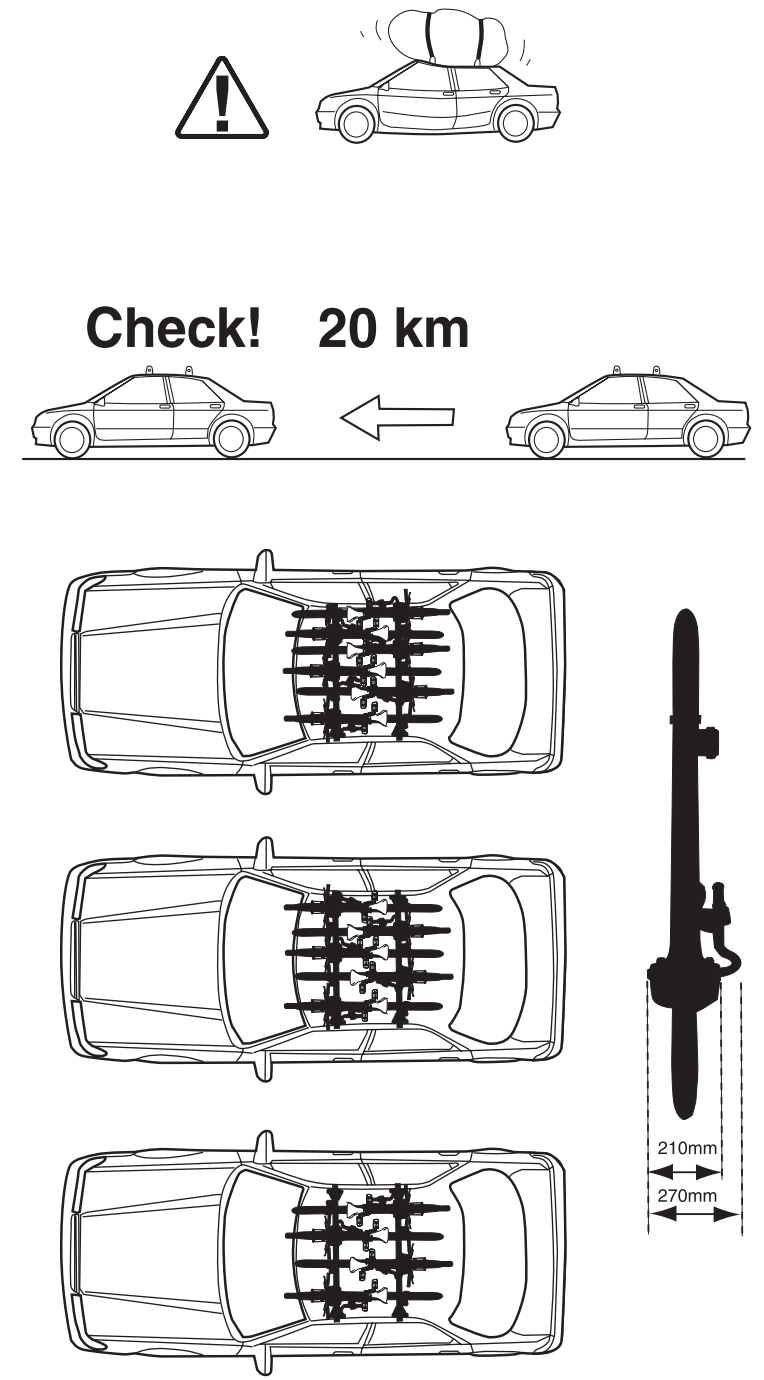
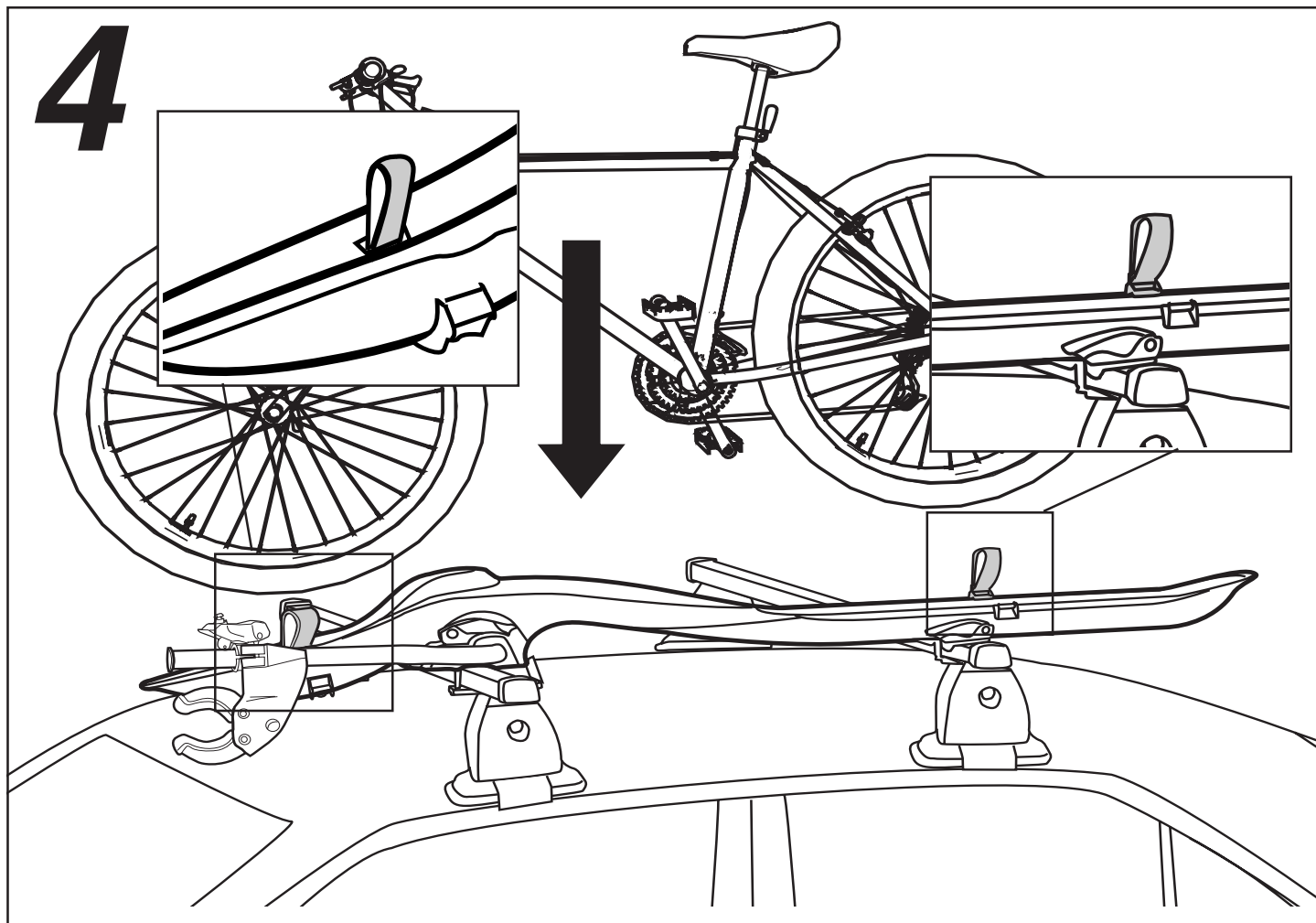
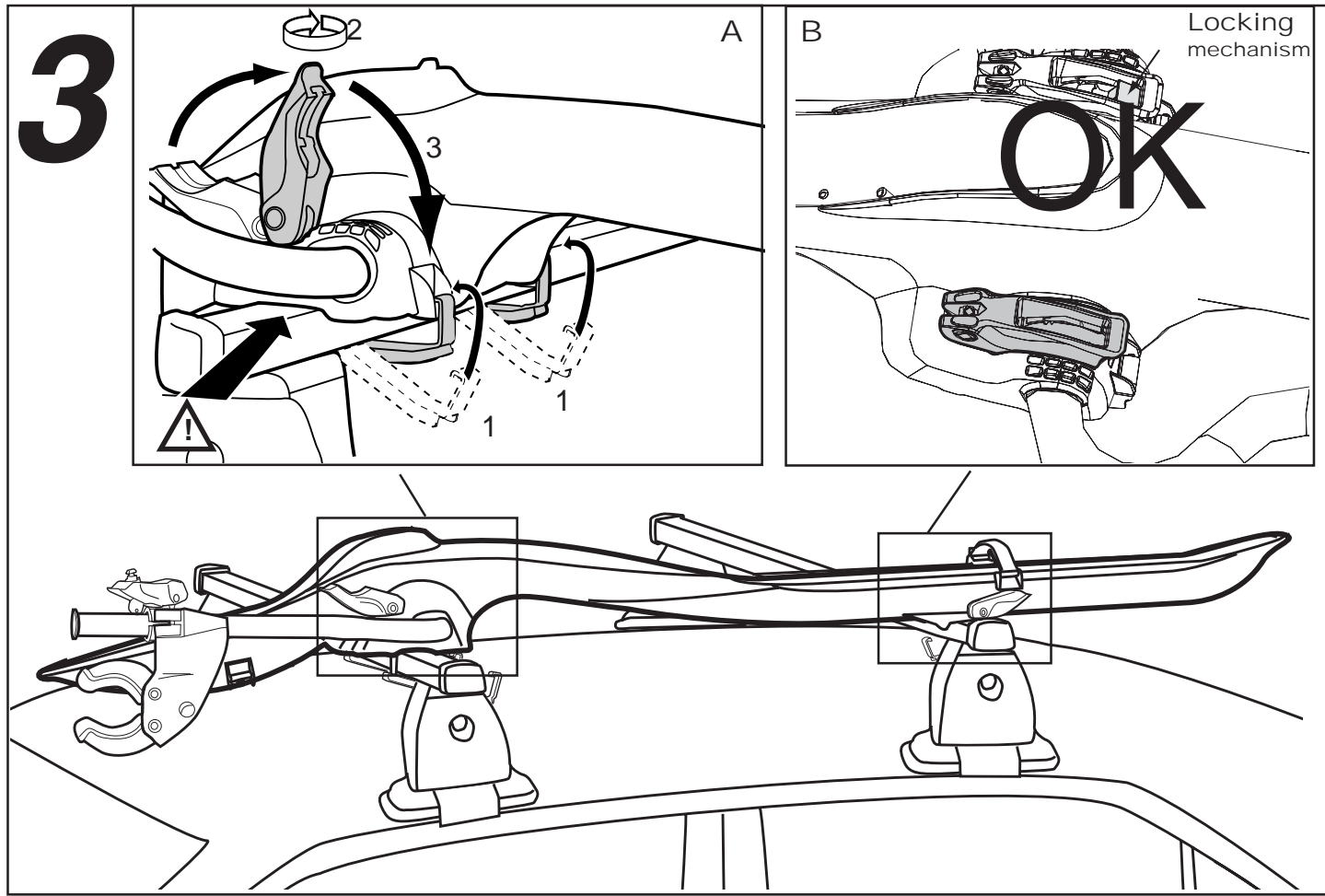

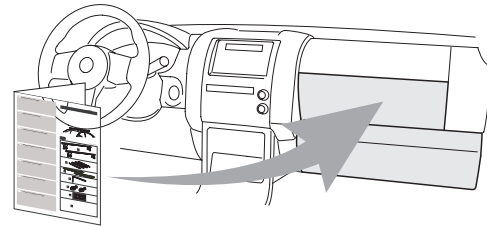
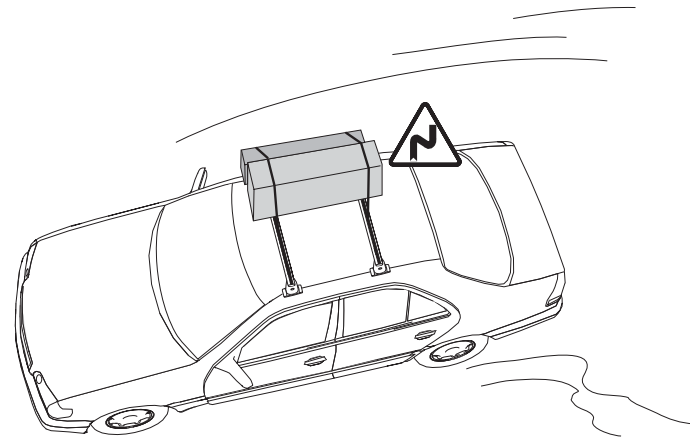
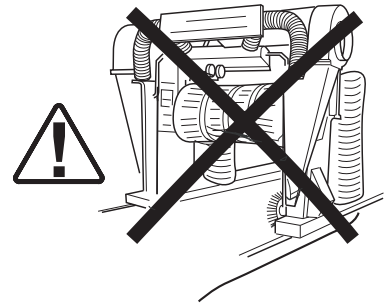
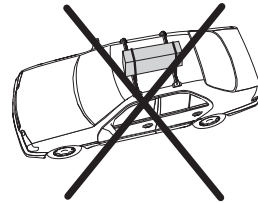
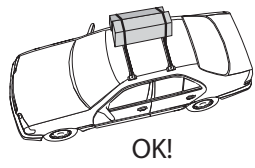
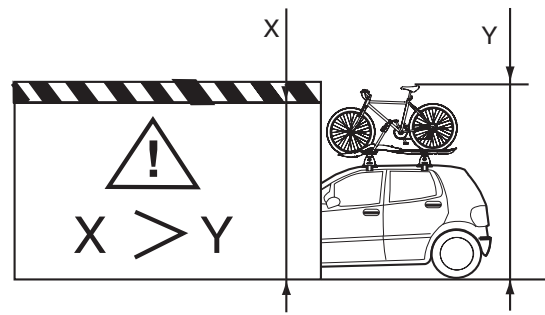
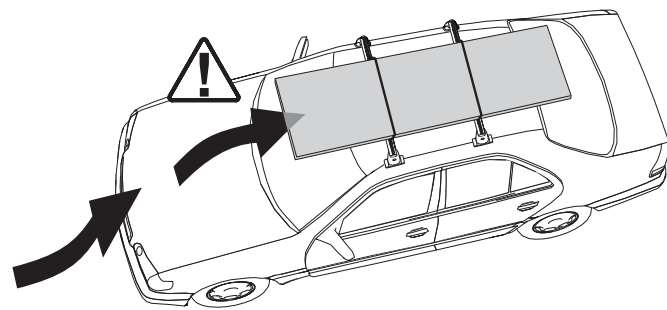

Check !

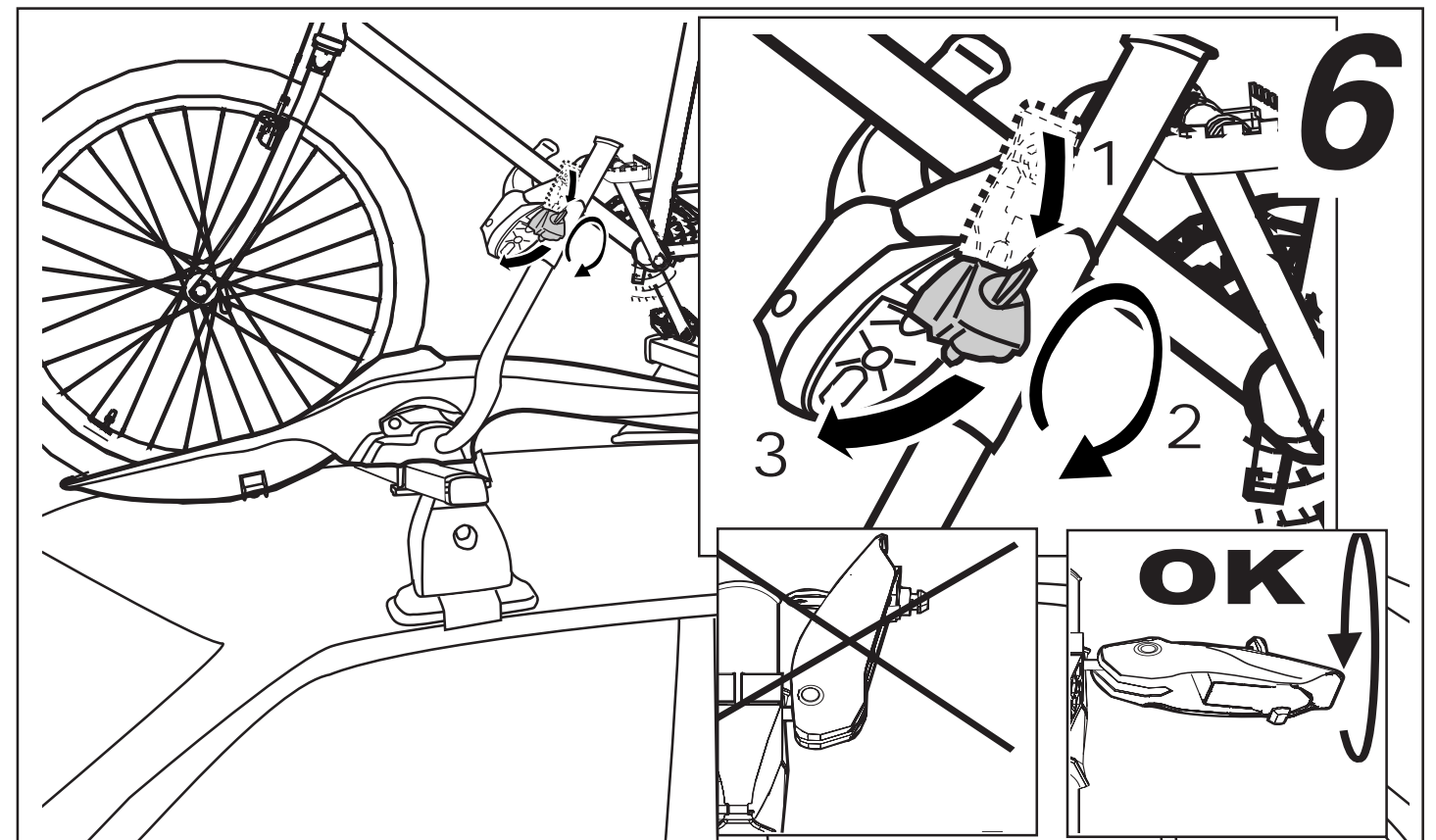
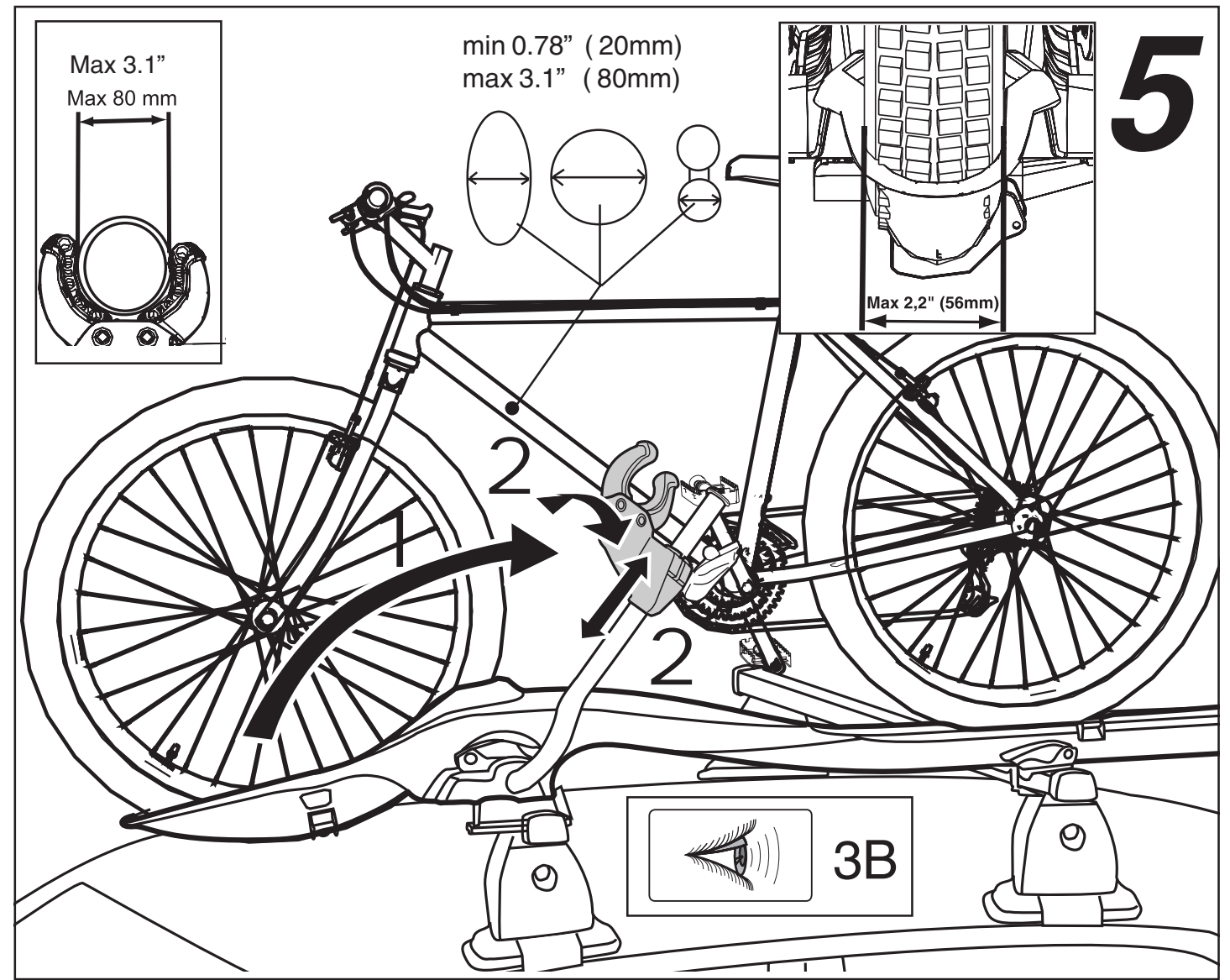
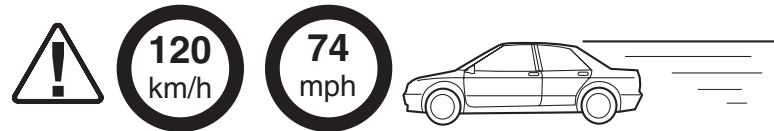

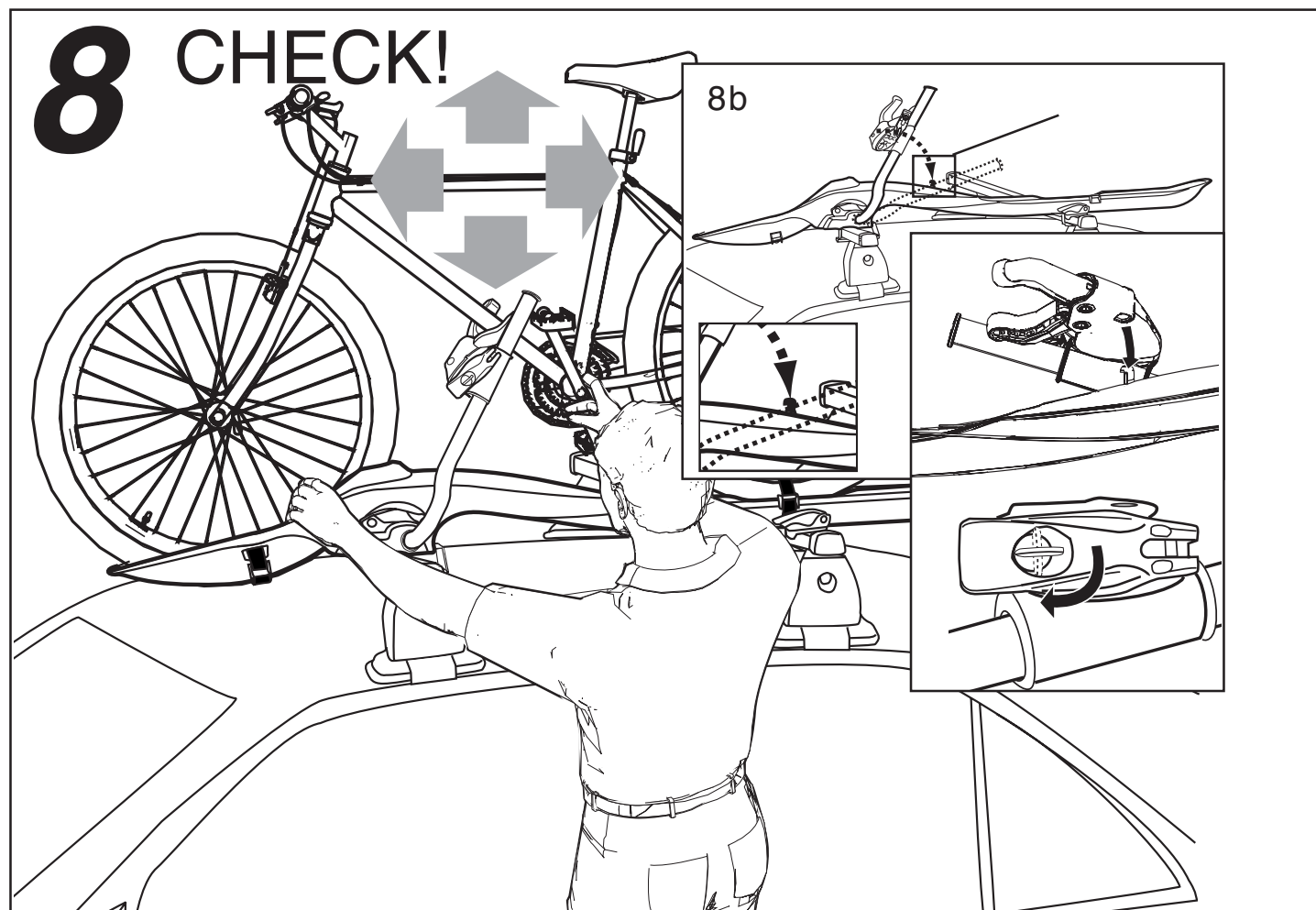
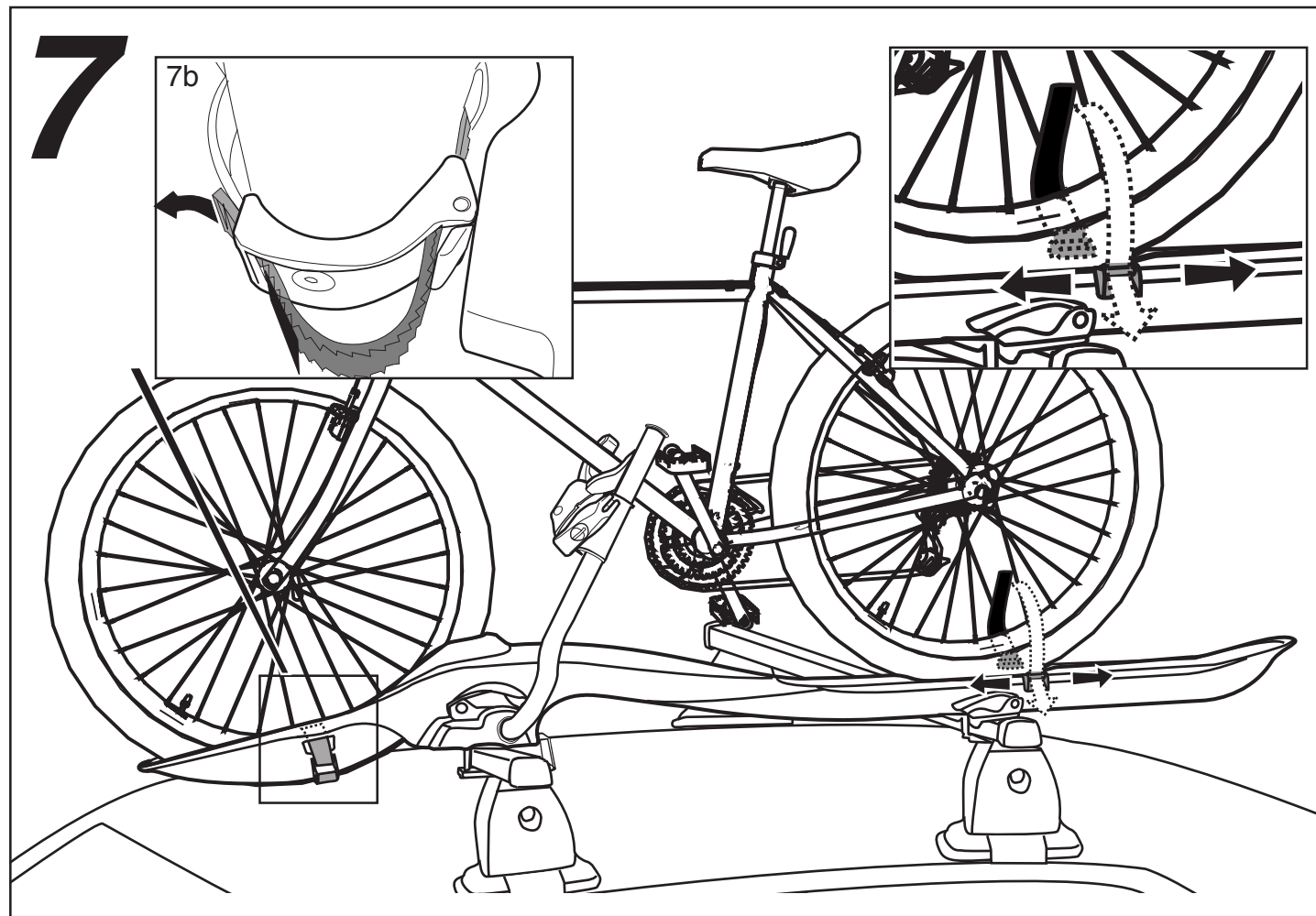

- EST Palun järgige kohalikke liikluseeskirju. Kütusekulu ja CO2 heitmete vähendamiseks palun eemaldage lastikandur, kui te seda ei kasuta. Tootja ei vastuta valesti paigaldatud lisatarvikute poolt tekitatud kahjude eest.
- LV Lūdzu, ievērojiet vietējos satiksmes noteikumus. Lai samazinātu degvielas patēriņu un CO2 izmešu līmeni, lūdzu, noņemiet bagāžas turētāju, kad tas netiek izmantots. Ražotājs neuzņemas atbildību par bojājumiem, kas radušies nepareizi uzstādītu piederumu dēļ.
- LT Laikykites vietas eismo taisyklių. Kad sumažintumėte degalų sąnaudas ir išmetamo CO2 kiekį, nuimkite bagažinę, kai ja nesinaudojate. Gamintojas neatsako už žalą ar nuostolius, patirtus dėl netinkamai pritvirtintų priedų.
- PL Należy stosować się do lokalnych przepisów ruchu drogowego. Jeżeli bagażnik nie jest wykorzystywany, w celu zmniejszenia zużycia paliwa i emisji CO2 należy go zdemontować. Producent nie ponosi odpowiedzialności za uszkodzenia spowodowane niewłaściwym montażem akcesoriów.
- CZ Řiďte se prosím místní vyhláškou o silničním provozu. Snížení spotřeby paliva a emisí CO2 dosáhnete odpojením přívesu. Výrobce neodpovídá za škody způsobené nesprávným použitím příslušenství.
- SK Riadte sa miestnou vyhláškou o cestnej premávke. Zníženie spotreby paliva a emisií CO2 dosiahnete odpojením privesu. Výrobca nezodpovedá za škody spôsobené nesprávnym použitím príslušenstva.
- SI Upošteвайте lokalne prometne predpise. Kadar ne uporabljate prtljavnika, ga odstranite. Tako boste zmanjšali porabo goriva in emisije CO2. Proizvajalec ne odgovarja za škodo, ki nastane zaradi nepravilno pritrdjene dodatne opreme.
- HR Pridržavajte se lokalnih prometnih propisa. Da biste smanjili potrošnju goriva i emisiju CO2, uklonite nosač kada ga ne koristite. Proizvođač se neće smatrati odgovornim za štetu uzrovanu nepravilno montiranom dodatnom opremom.
- RS Pridržavajte se lokalnih saobraćajnih propisa. Radi smanjenja potrošnje goriva i emisije CO2, skinite nosač kada nije u upotrebi. Proizvođač nije odgovoran za oštećenja nastala nepravilnom montažom pribora.
- HU Kérjük, kövesse a helyi közlekedési szabályokat. Az üzemanyag-fogyasztás és a széndioxid-kibocsátás csökkentése érdekében távolítsa el az utánfutót, ha nem használja. A gyártó nem vonható felelősségre a nem megfelelően felszerelt tartozékok által okozott károkért.
- BG Моля, спазвайте местния правилник за движение по пътищата. С цел намаляване разхода на гориво и емисиите на въглероден диоксид, моля, отстранявайте ремаркето, когато то не се използва. Производителят не носи отговорност за щети, причинени от неправилно монтирани допълнителни елементи.
- GR Ακολουθήστε τους τοπικούς κανόνες κυκλοφορίας. Για να μειώσετε την κατανάλωση καυσίμων και την εκπομπή CO2, αφαιρέστε τη βάση μεταφοράς φορτίου όταν δεν την χρησιμοποιείτε. Ο κατασκευαστής δεν φέρει ευθύνη για ζημιές που τυχόν προκληθούν λόγω λανθασμένης τοποθέτησης εξαρτημάτων.
- TR Lütfen yerel trafik kurallarına uyun. Yakıt tüketimi ve CO2 emisyon azaltımı için, lütfen kullanılmadığı zamanlarda yük taşıyıcısını çıkartın. Üretici, yanlış takılmış aksesuarların neden olacağı zarardan sorumlu tutulamaz.
- RU Следуйте правилам дорожного движения, действующим в вашем регионе. Чтобы уменьшить потребление топлива и выброс диоксида углерода в атмосферу, следует убирать багажник, когда он не используется. Производитель не несет ответственность за ущерб, причиненный вследствие неверно установленных аксессуаров.

IL אגא הקפד על חוקי התנועה המקומיים. להפחית צריכת הדלק ופליטת CO<sub>2</sub>, אגא הסר את נושא המטען כאשר אינו בשימוש. היצרן אינו אחראי לנזק שייגרם כתוצאה משימוש באביזרים שלא הותקנו והותאמו כנדרש.

- GB Please follow local traffic regulations.  
For fuel consumption and CO2 emission reduction, please remove load carrier when not in use.  
The manufacturer can not be held responsible for damage caused by incorrectly fitted accessories.
- D Beachten Sie die örtlichen Verkehrsvorschriften.  
Wenn der Träger nicht verwendet wird, sollte er entfernt werden, um den Kraftstoffverbrauch und CO2-Ausstoß zu verringern.  
Der Hersteller kann nicht für Schäden haftbar gemacht werden, die auf eine unsachgemäße Montage des Zubehörs zurückzuführen sind.
- F Respecter les règles de circulation en vigueur au niveau local.  
Afin de limiter la consommation de carburant et les émissions de CO2, retirer les barres de toit lorsque celles-ci ne sont pas utilisées.  
Le fabricant ne peut être tenu pour responsable des dommages résultant d'une erreur de montage des accessoires.
- NL Volg de ter plaatse geldende verkeersregels.  
Om het brandstofverbruik en de CO2-emissie te verlagen, moet de allesdrager worden verwijderd als deze niet wordt gebruikt.  
De fabrikant kan niet aansprakelijk worden gesteld voor schade die door onjuist gemonteerde accessoires is veroorzaakt.
- I Rispettare sempre il codice della strada.  
Per ridurre il consumo di carburante e le emissioni di CO2, smontare sempre il portapacchi quando non viene utilizzato.  
Il produttore non potrà essere ritenuto responsabile per eventuali danni dovuti al montaggio errato degli accessori.
- E Cumpla la normative local de tráfico.  
Para reducir el consumo de combustible y las emisiones de CO2, retire el portaobjetos cuando no esté en uso.  
El fabricante no se responsabilizará de cualquier daño producido por un ajuste incorrecto de los accesorios.
- P Siga as regras de trânsito locais.  
Para reduzir o consumo de combustível e a emissão de gás carbônico (CO2), remova o bagageiro quando ele não estiver em uso.  
O fabricante não pode ser responsabilizado por danos causados por acessórios instalados de forma incorreta.
- S Vänligen följ lokala trafikregler.  
Montera av lasthållaren för att minska CO2-utsläpp och bränsleförbrukning när den ej används.  
Tillverkaren tar inget ansvar för skador som uppstår till följd av felmontering.
- N Vennligst følg lokale trafikregler.  
Demonter lastholderen når den ikke er i bruk. for å minske CO2-utslipp.  
Fabrikanten er ikke ansvarlig for skader som oppstår som følge av feilmontering.
- FIN Noudata paikallisia liikennesääntöjä.  
Vähennä polttoaineen kulutusta ja hiilidioksidipäästöjä poistamalla taakkateline, kun et käytä sitä.  
Valmistajaa ei voi pitää vastuullisena vahingosta, joka on aiheutunut väärin asennetuista tarvikkeista.
- DK Følg de lokale trafikregler.  
Afmonter lastholderen for at reducere CO2-udslip og brændstofforbrug, når den ikke anvendes.  
Producenten overtager intet ansvar for skader, der opstår pga. forkert montering.
- IS Vinsamlegast fylgdu staðbundnum umferðarreglum.  
Fjarlægðu toppgrindina þegar hún er ekki í notkun til að spara eldsneyti og minnka útblástur koltvísýrings.  
Framleiðandinn ber enga ábyrgð á skemmdum vegna rangrar festingar aukahluta.
- RO Vă rugăm să respectați regulile de circulație locale.  
Pentru reducerea consumului de combustibil și a emisiei de dioxid de carbon, îndepărtați portbagajul atunci când nu îl utilizați.  
Producătorul nu poate fi făcut responsabil pentru avarierea cauzată de accesoriile montate necorespunzător.

