

# Side Steps INSTALLATION INSTRUCTIONS NX

Model year As from 2021/09  
Vehicle code AAZ\*\*\*\*-AW\*LBW  
TAZA25L-AWZLTW  
MAZA20L-AW\*LBW  
Part number PW388-78000 Side steps  
90467-22017 Replacement clips





# Revision Record

Rev. No.	Date	Page	Step	Remarks
①	08.12.22	15, 20	19, C/S	Step & Check added
①	08.12.22	16-17		Owners' Manual added



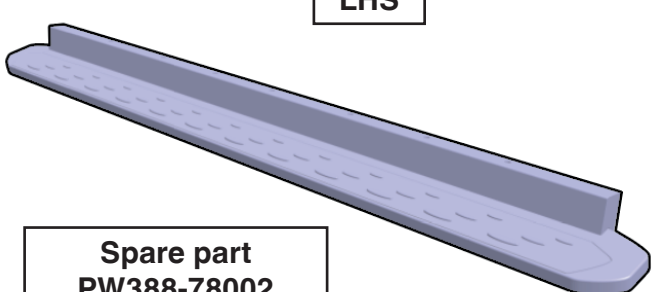
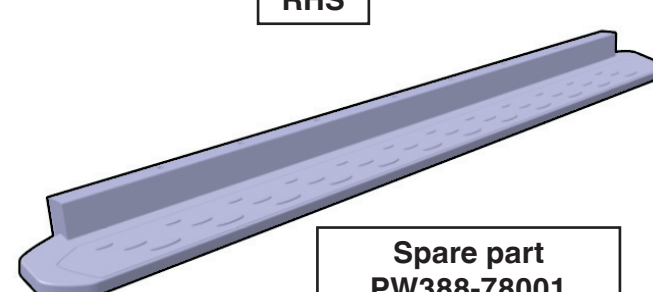

## KIT CONTENT

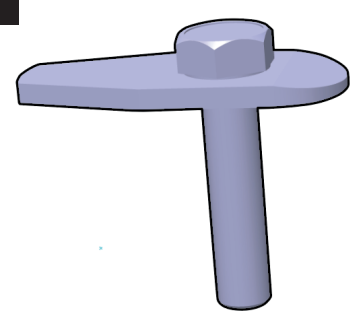
PW388-10001

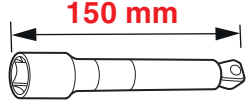

<p><b>A</b></p> <p>LHS</p>  <p>Spare part PW388-78002</p> <p>1x</p>	<p><b>B</b></p> <p>RHS</p>  <p>Spare part PW388-78001</p> <p>1x</p>		
<p><b>C</b></p>  <p>1x</p>	<p><b>D</b></p>  <p>10x</p>	<p><b>E</b></p>  <p>10x</p>	<p><b>F</b></p>  <p>10x</p>

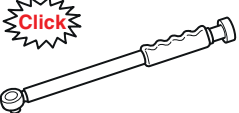
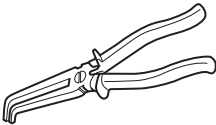
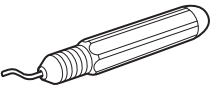
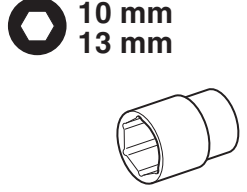
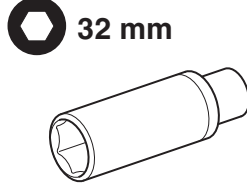

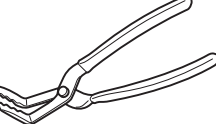
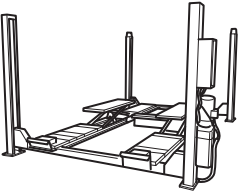
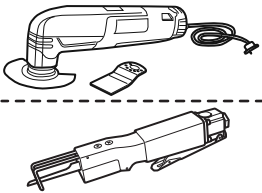
## TOOLS

## CONSUMABLES

<b>CLEANER / DEGREASER SPRAY</b>	<b>MASKING TAPE</b>		
 AIM 003 517-*			

## PERSONAL PROTECTION EQUIPMENT

			
---	---	--	--

For Symbols  
Explanation  
SCAN HERE



# GENERAL



Material Safety Data Sheet



Technical Data Sheet

40°C

18°C

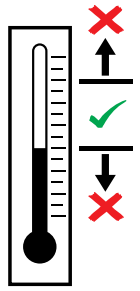

# LEGEND

=  XX mm	=  or	=
=  XX mm	=	=
=	=	=
=  TXX	=	= <b>START</b>

# INSTALLATION INSTRUCTIONS

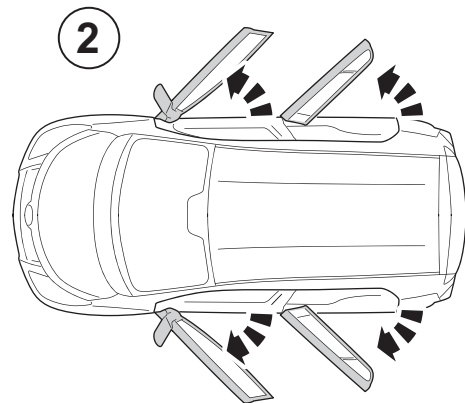
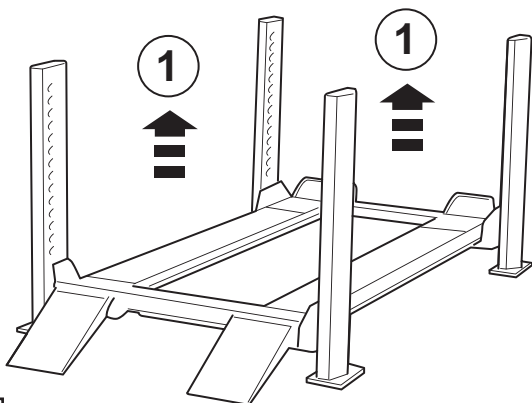

1

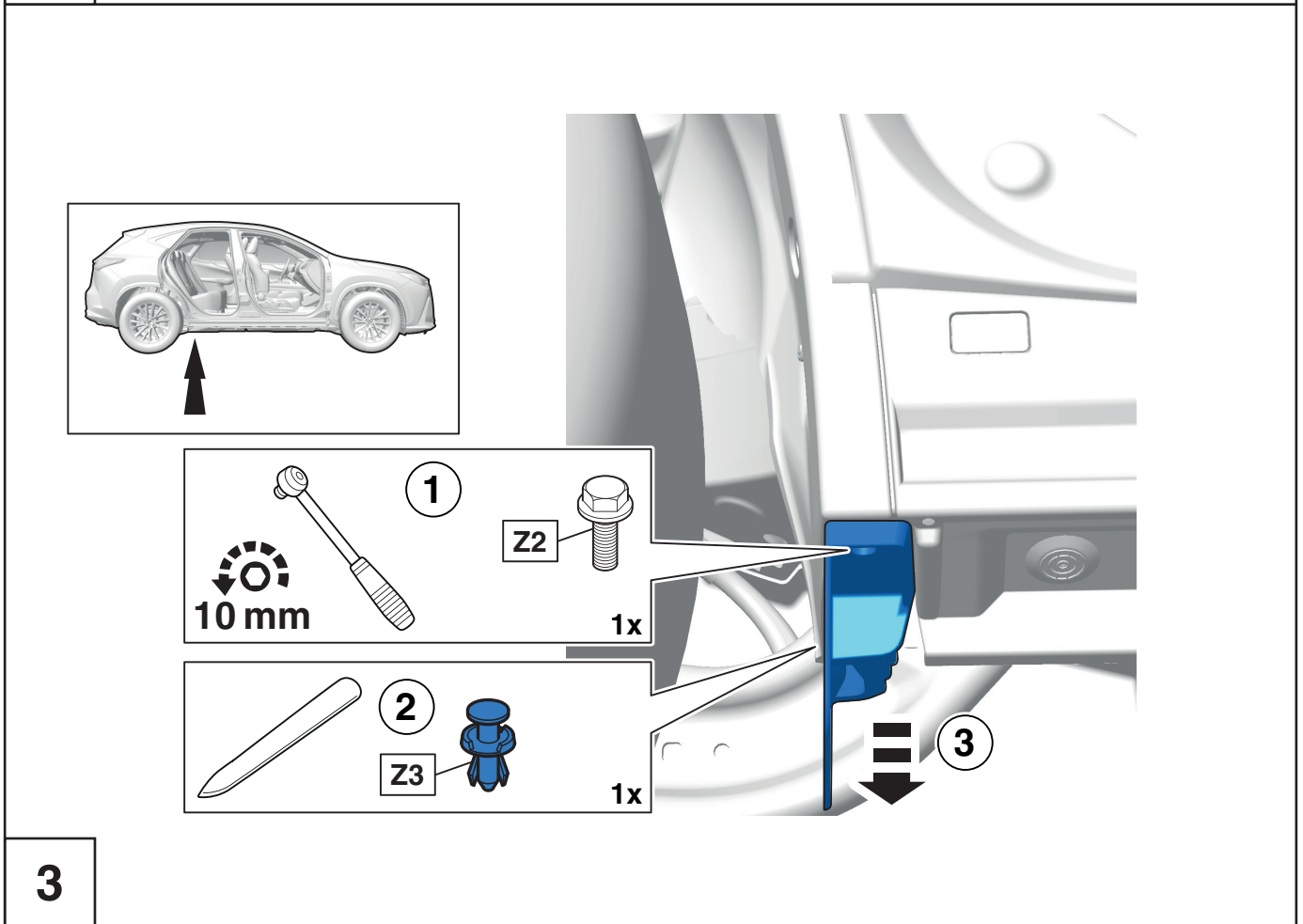
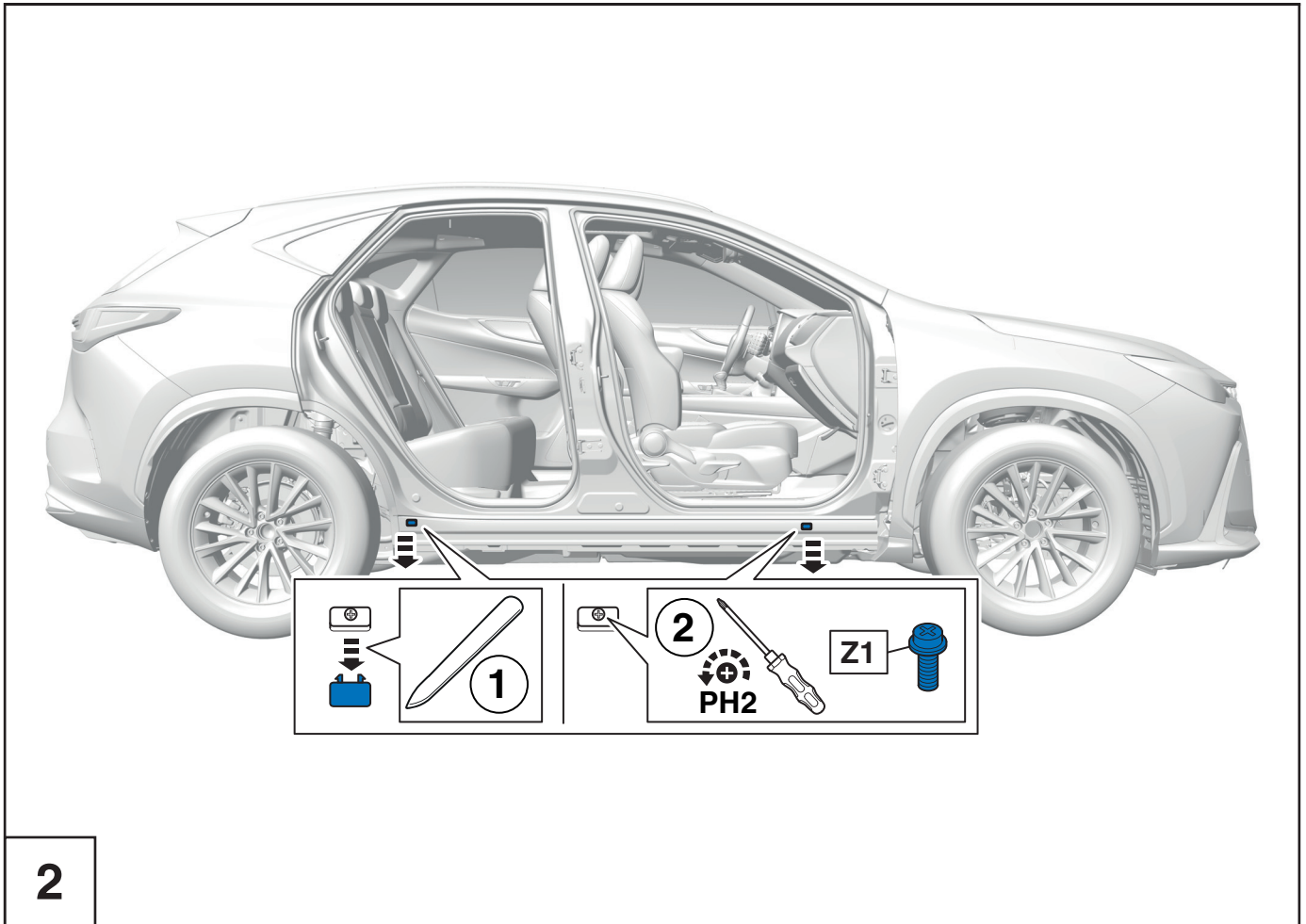

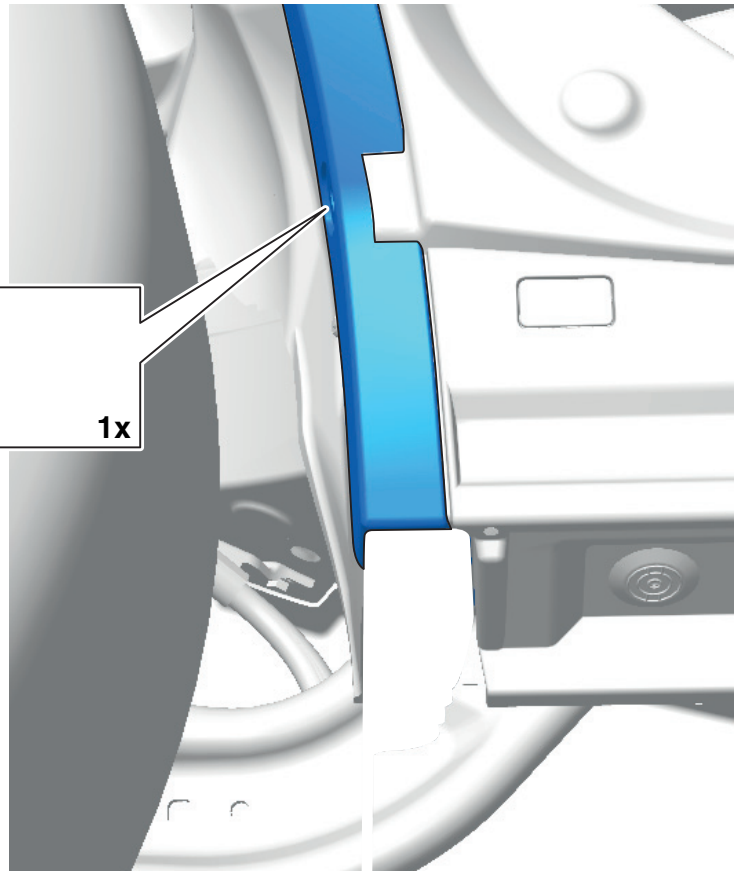
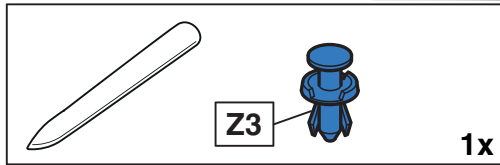
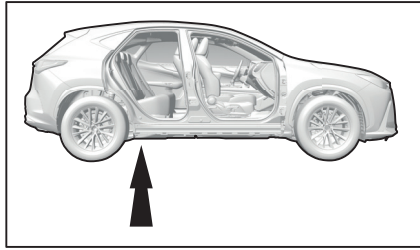

4

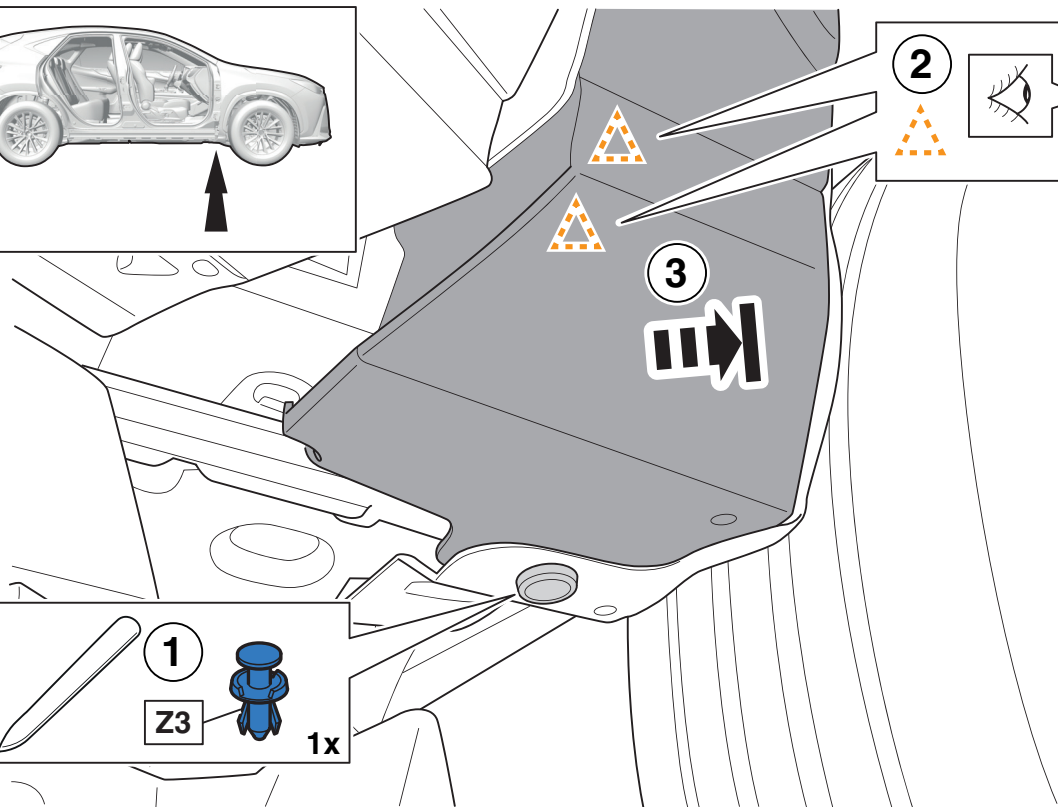
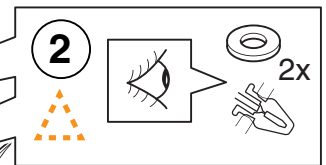
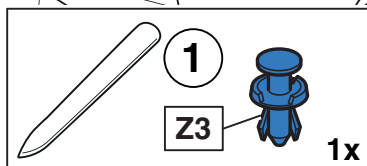
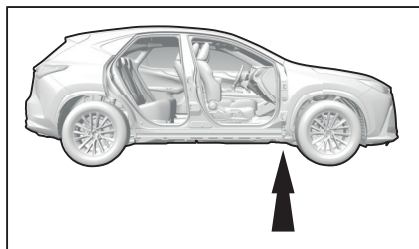

5

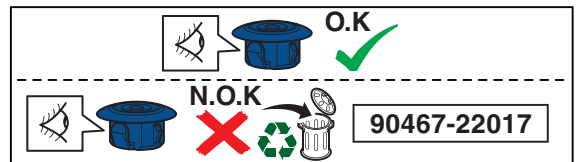
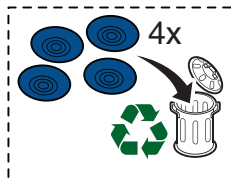
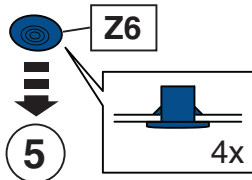
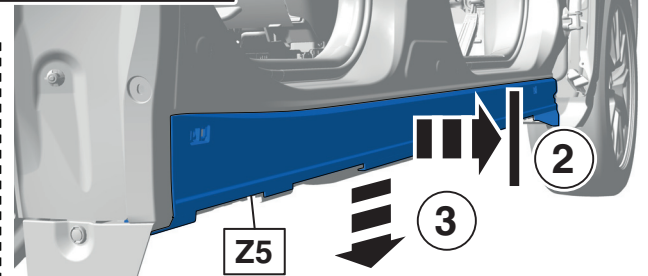
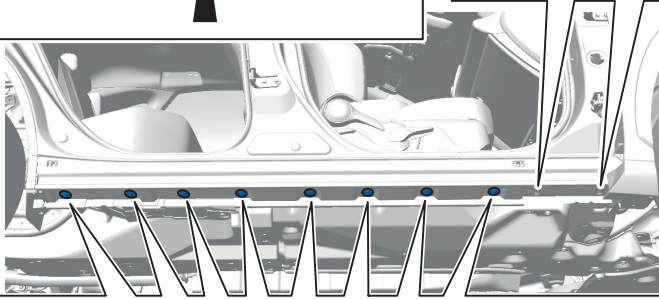
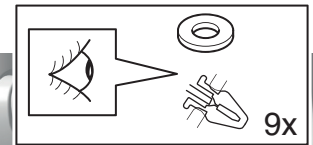
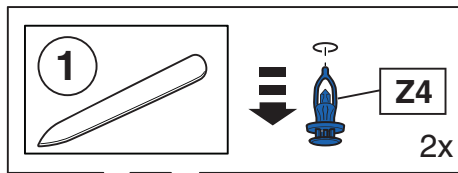
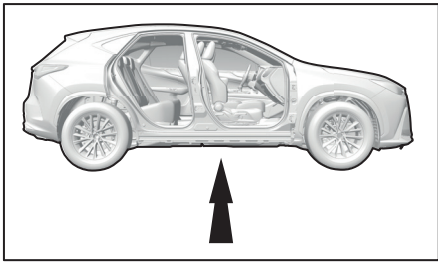

6

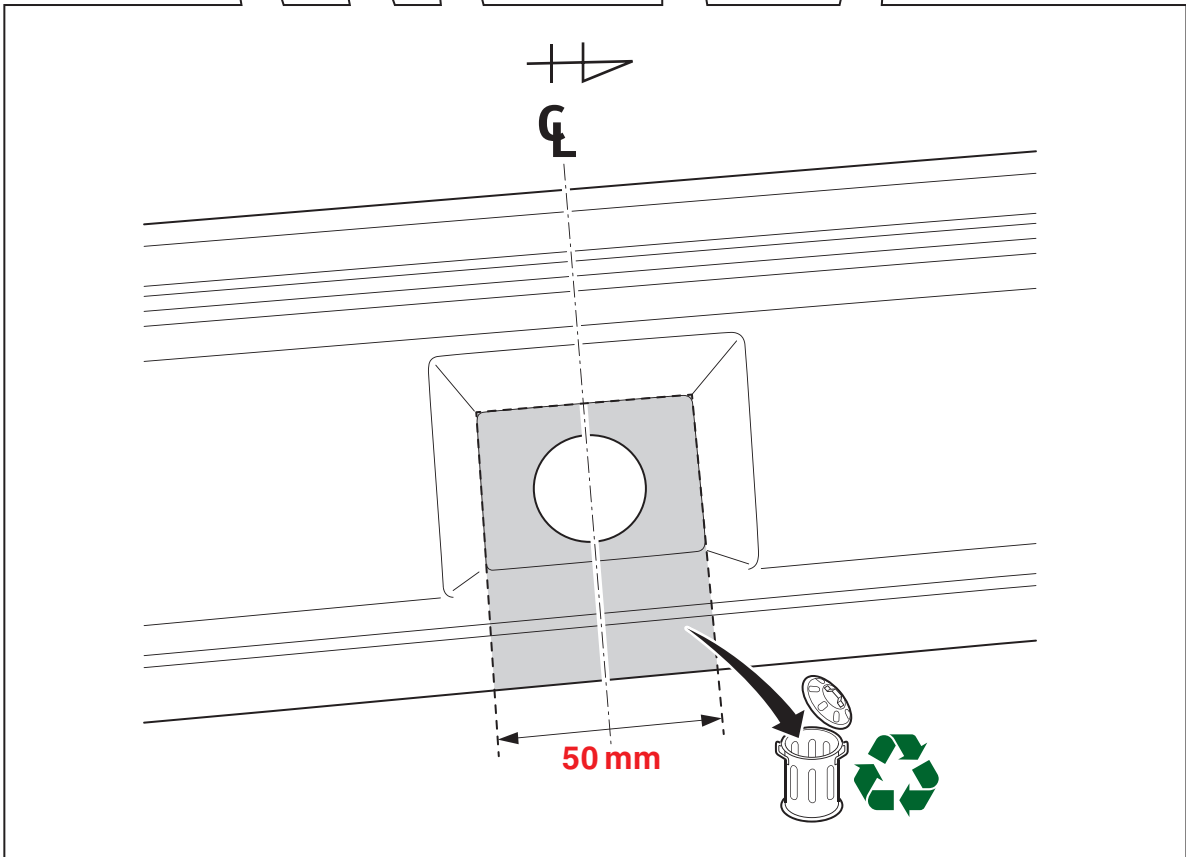
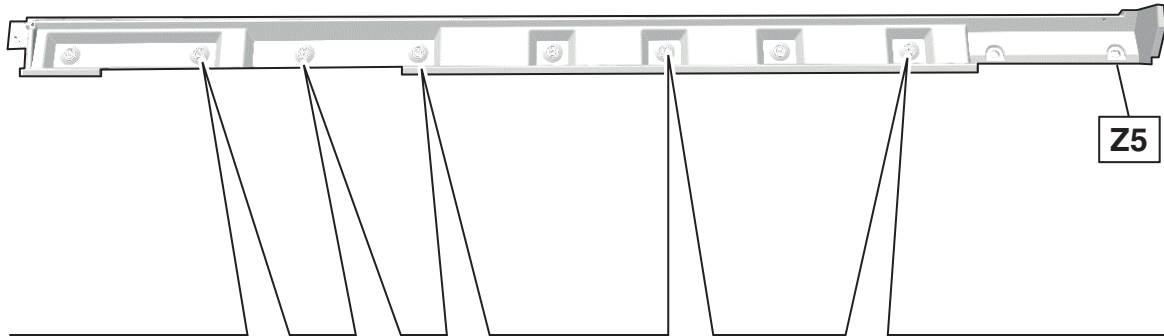
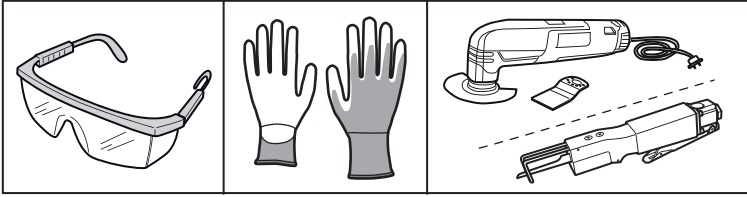

7



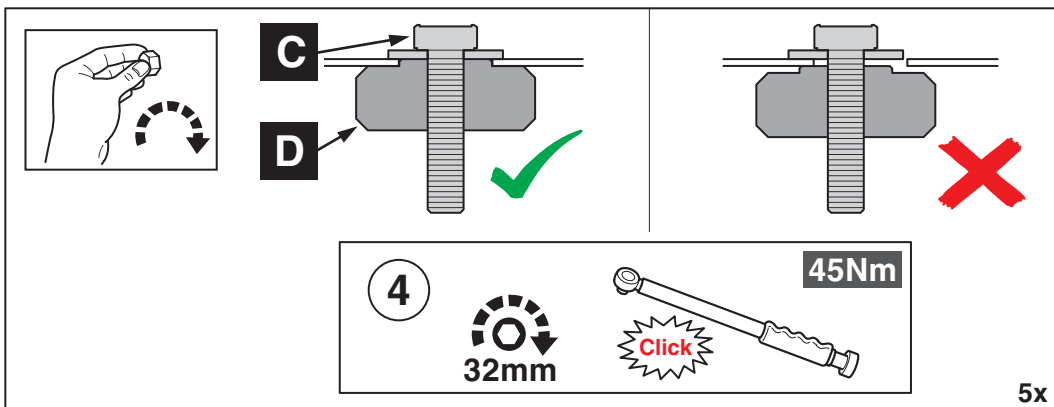
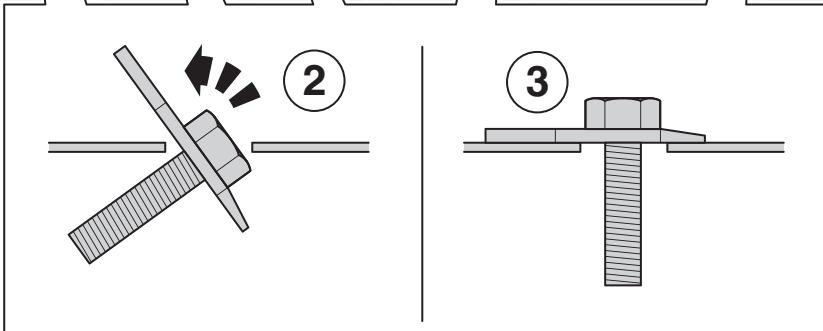
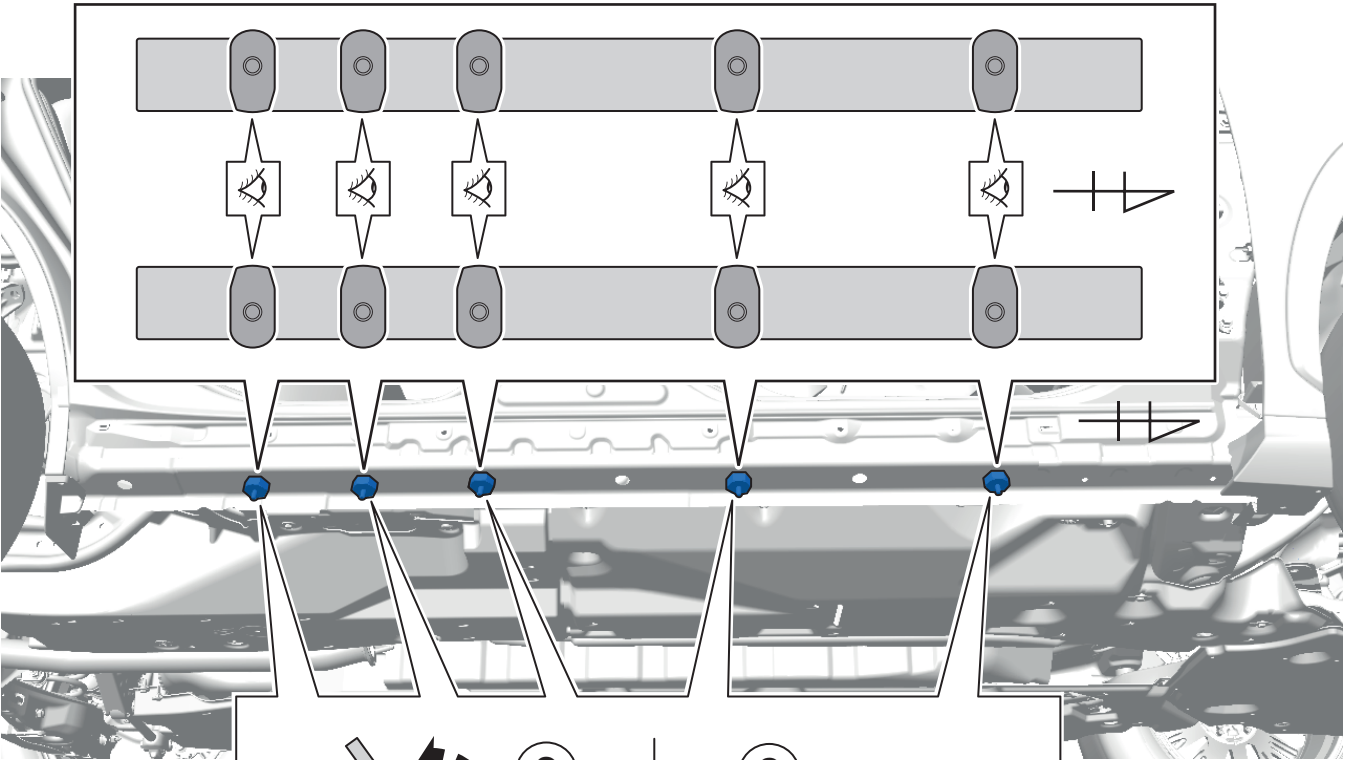
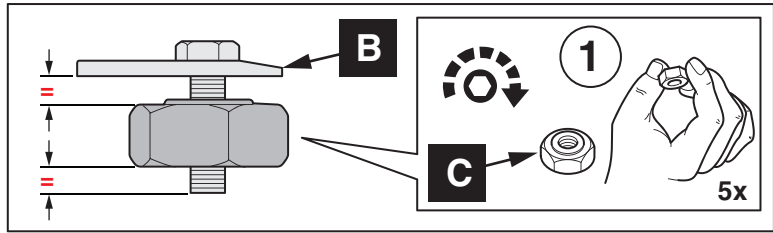
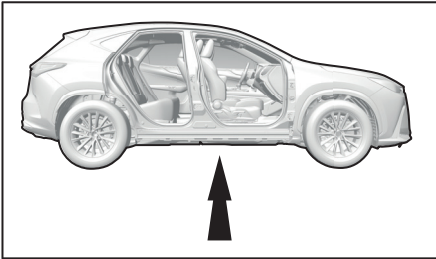

8

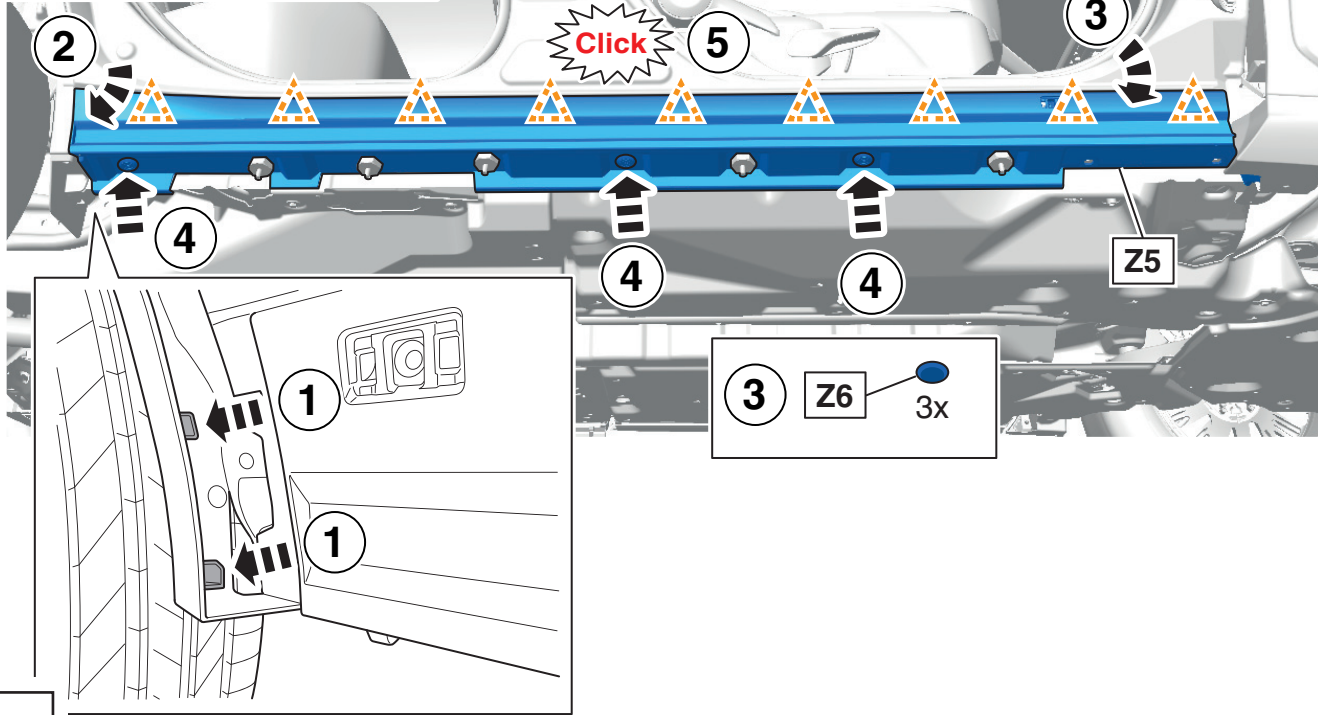
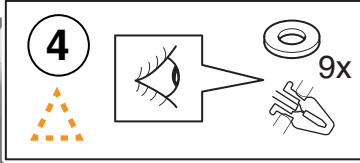
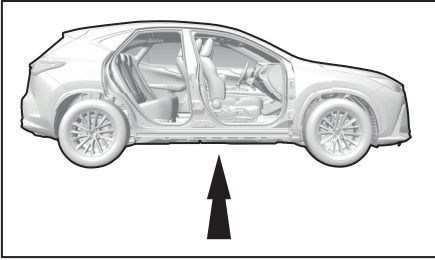

9

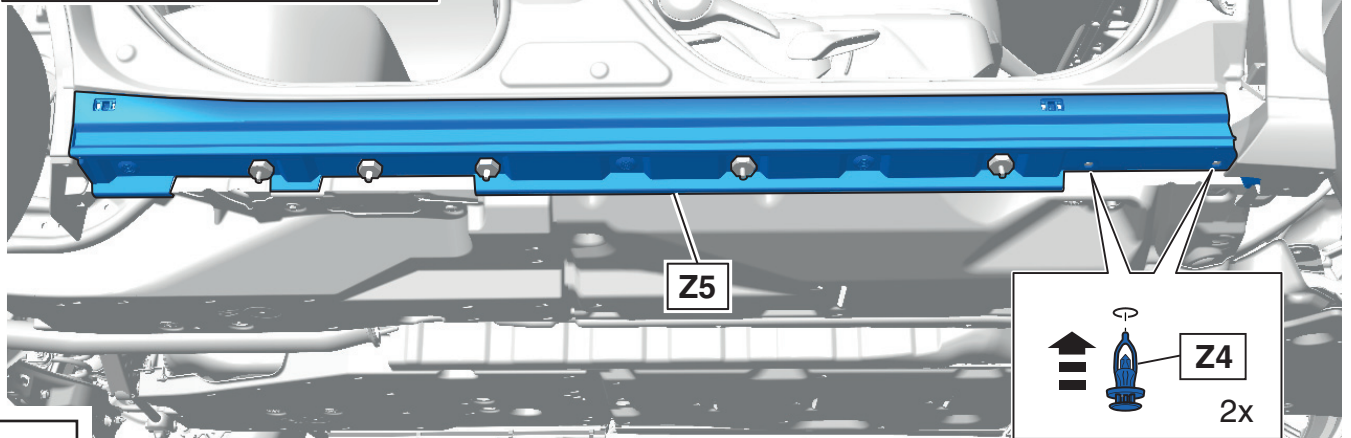
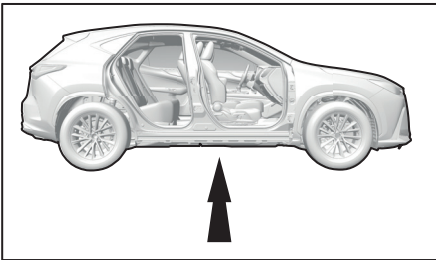

10

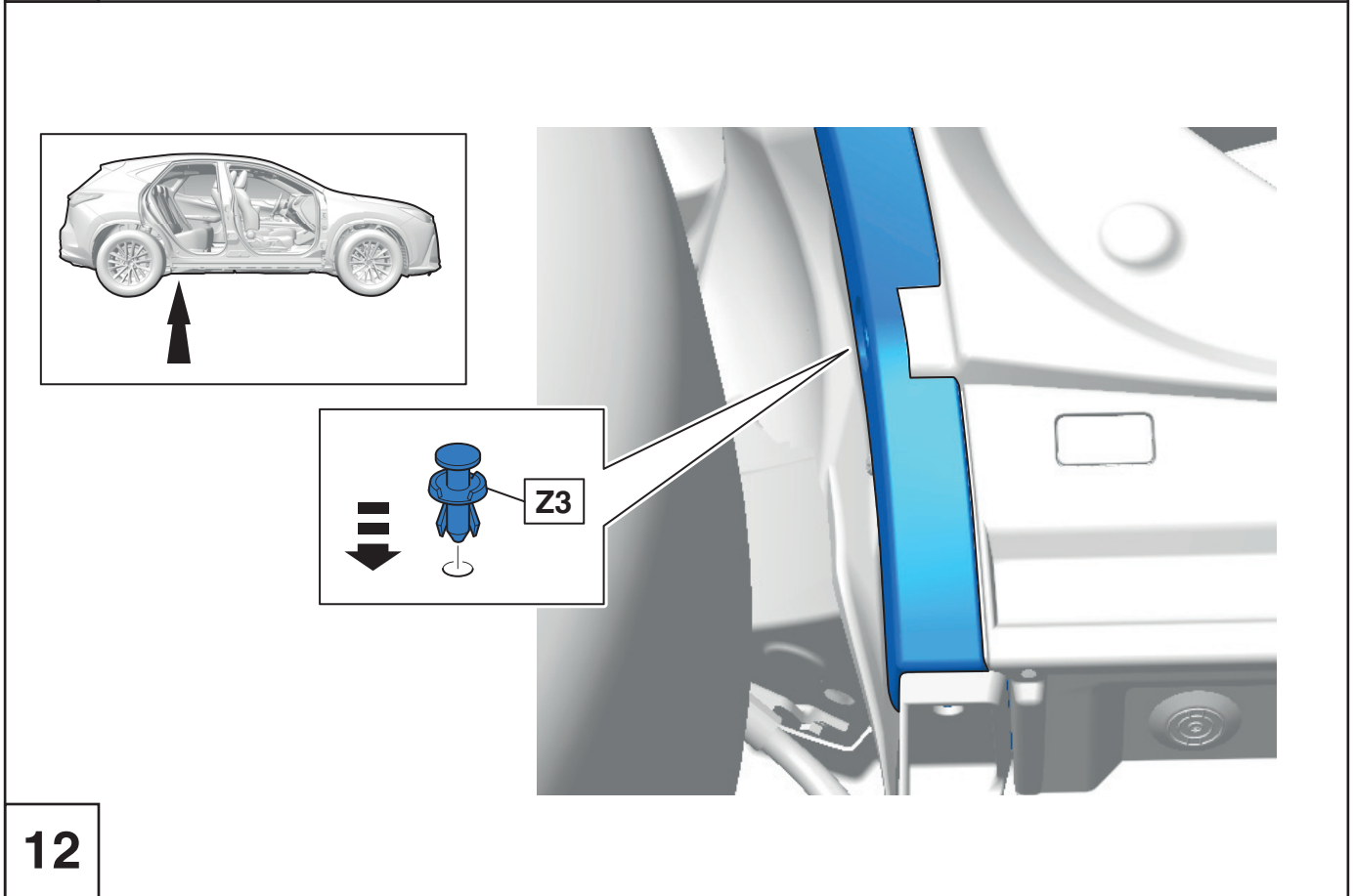
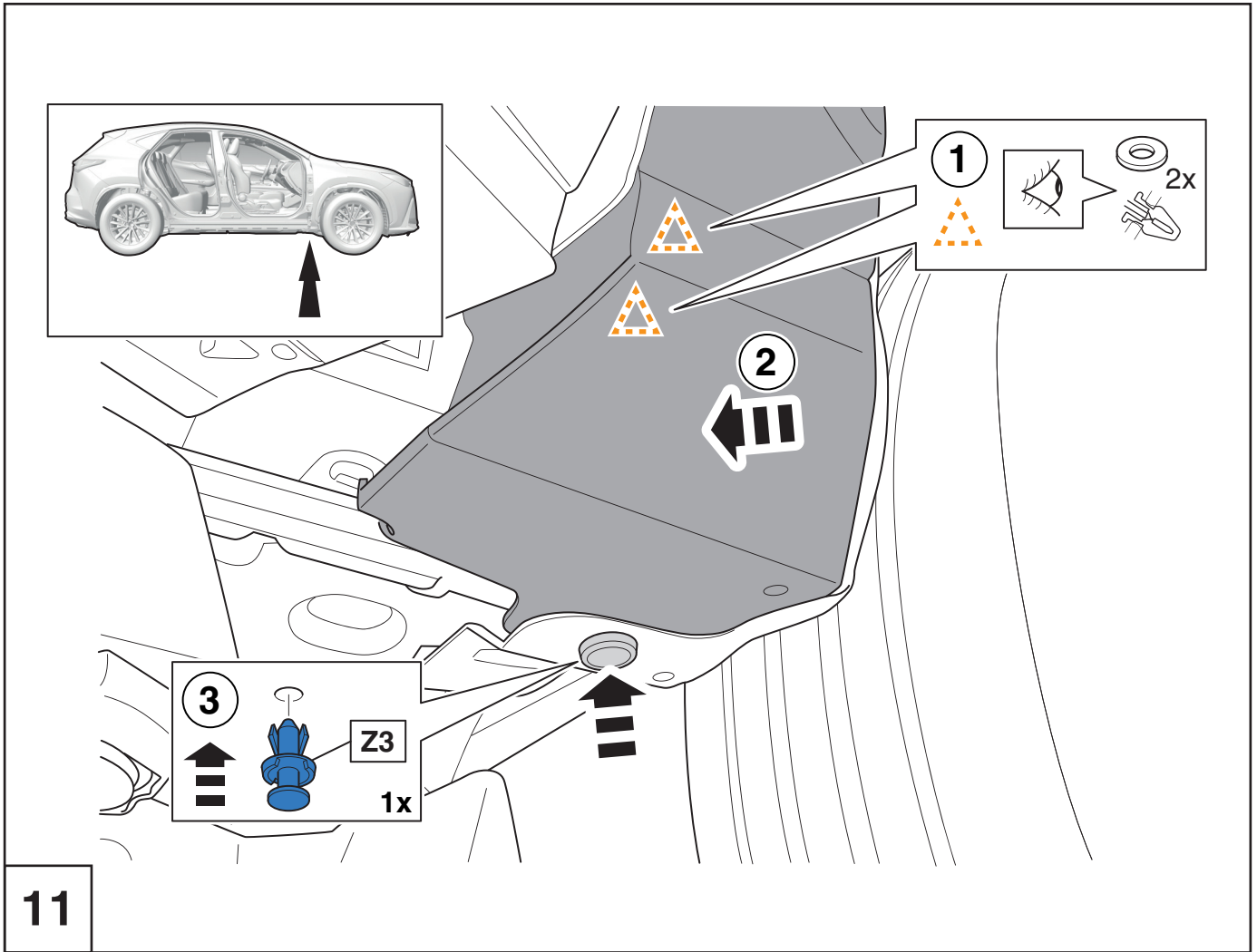

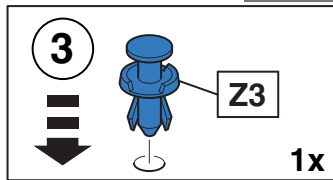
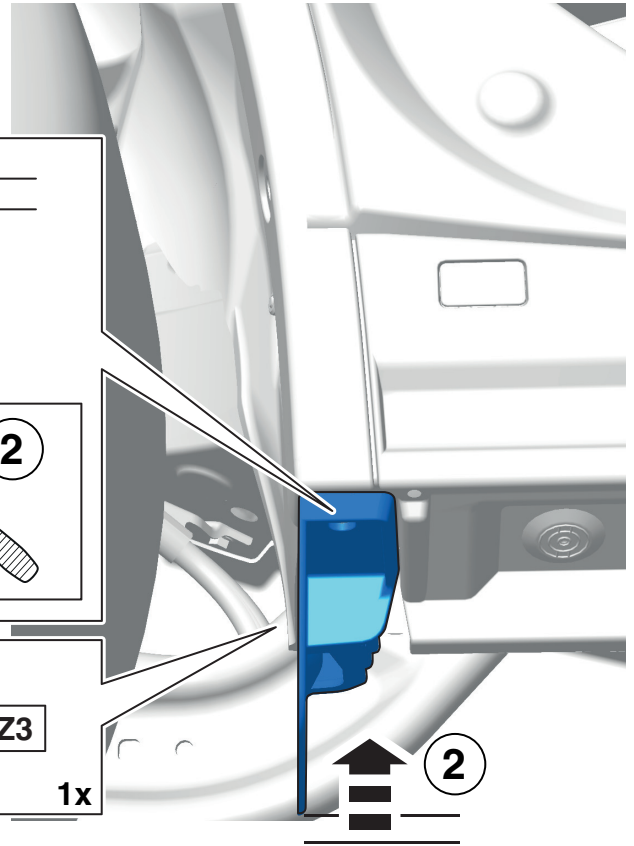
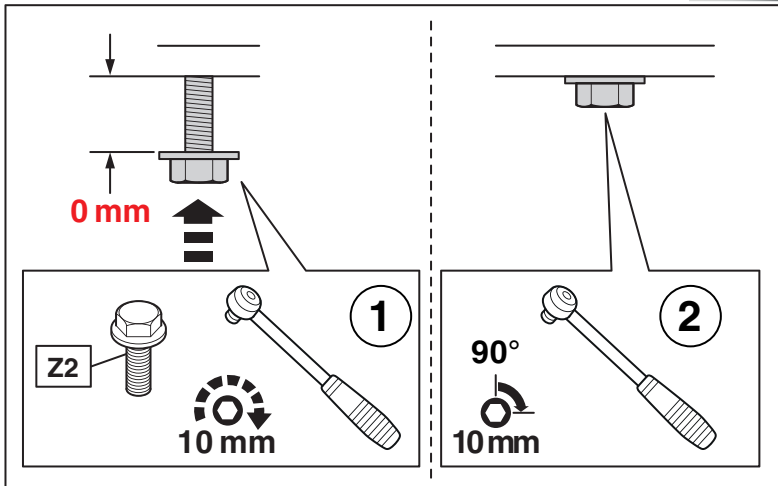
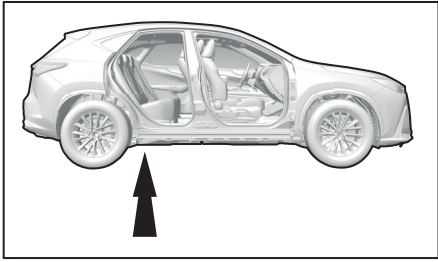

13

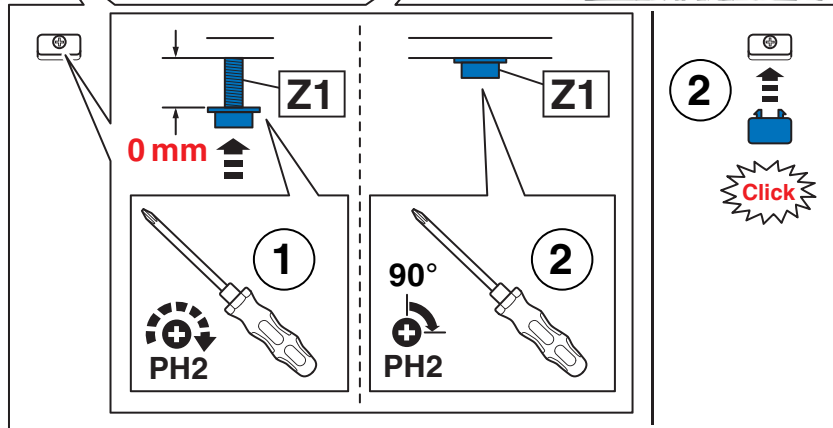
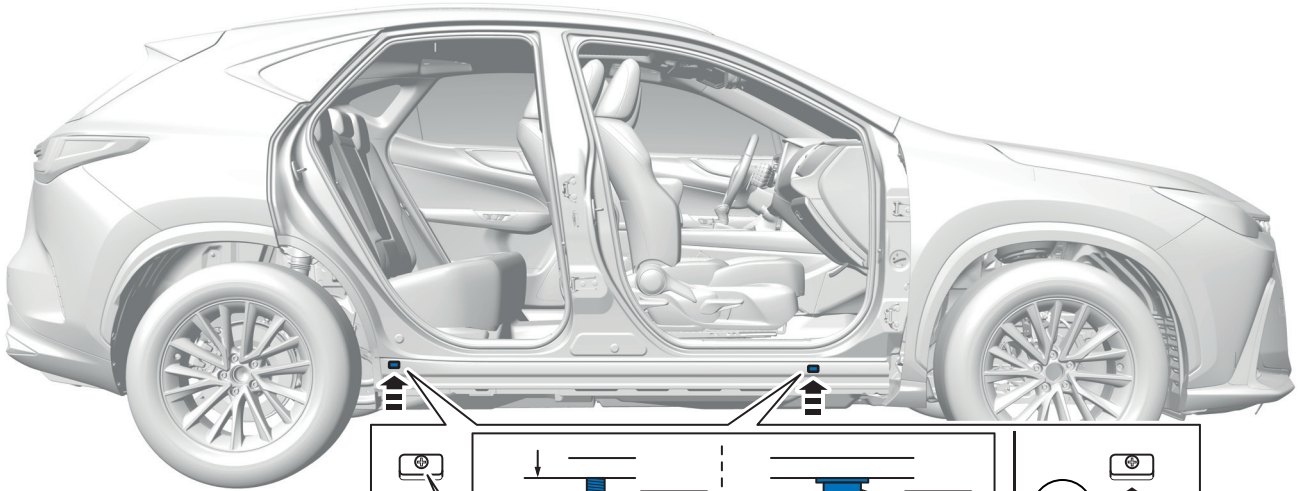

14



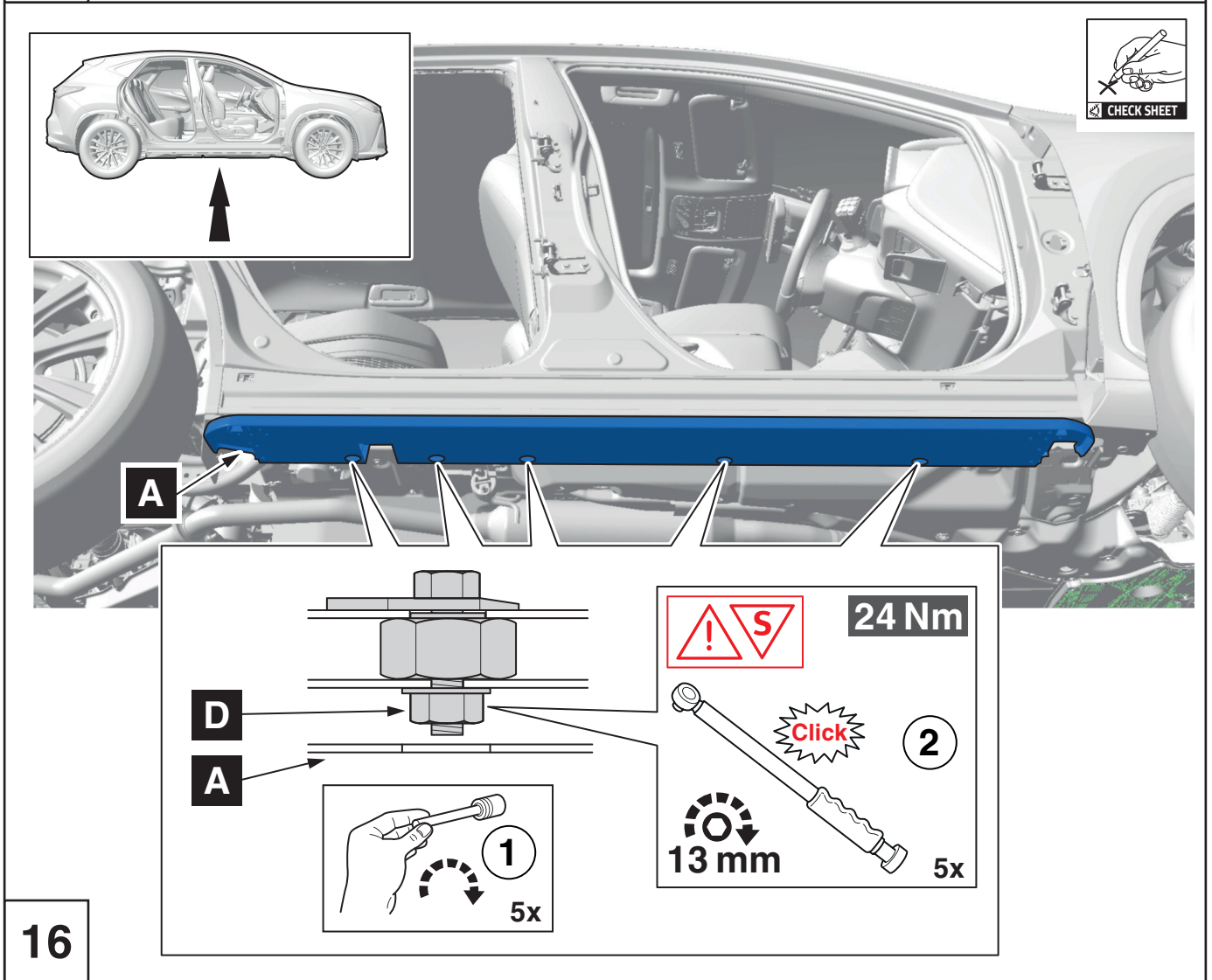
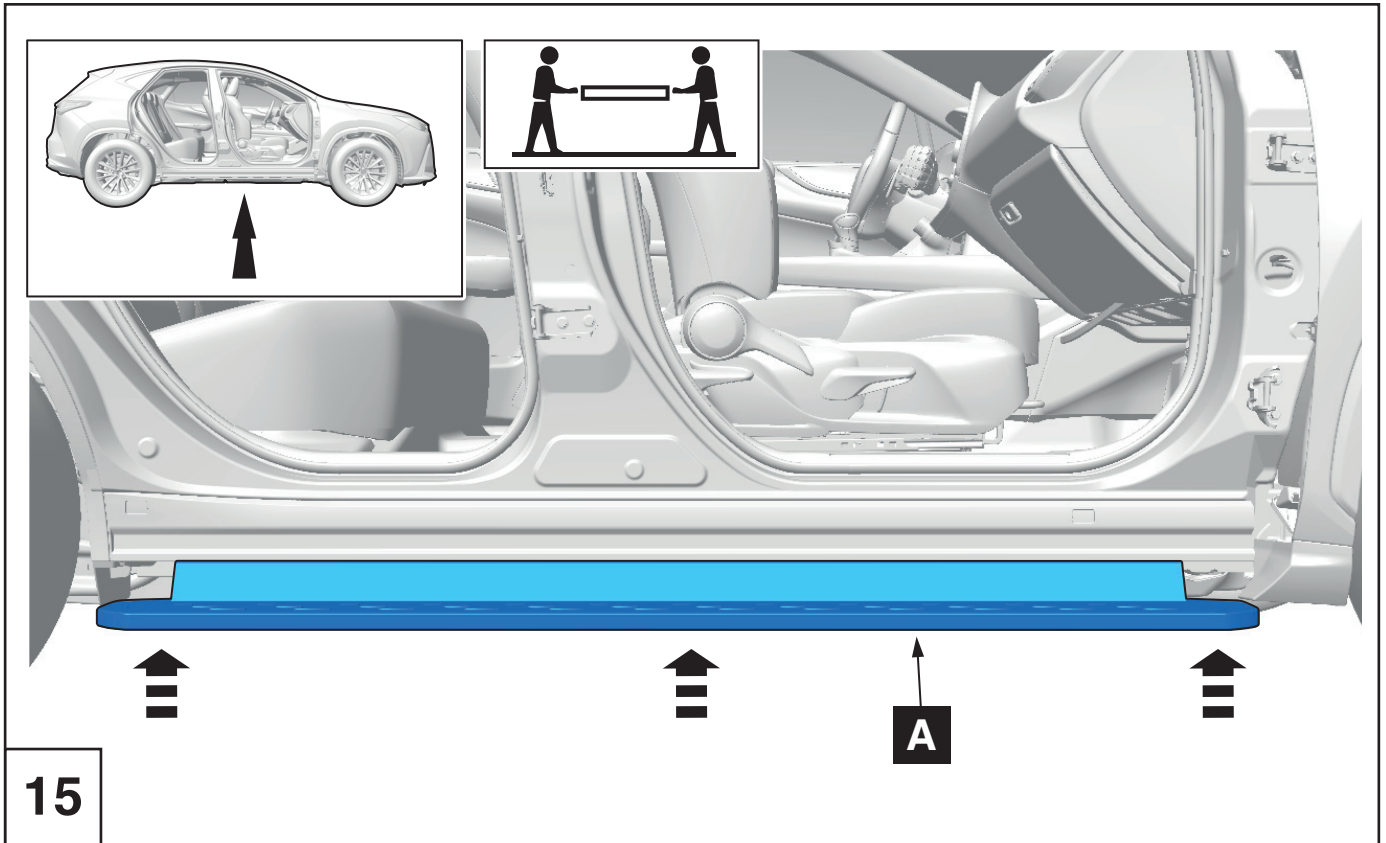

RHS = LHS

2

—

16

17

### WITH TIRE REPAIR KIT

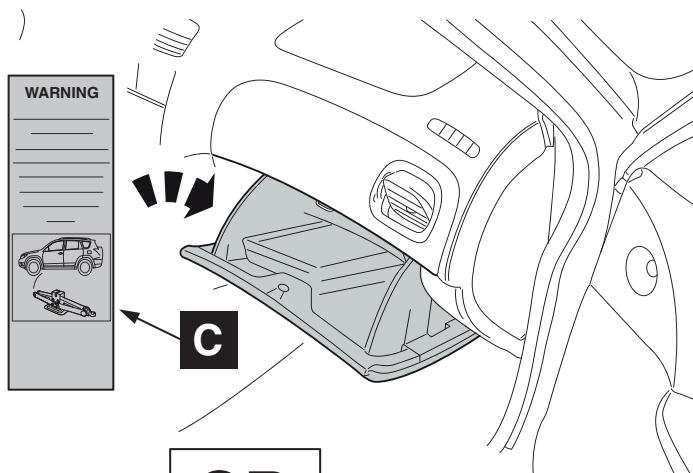
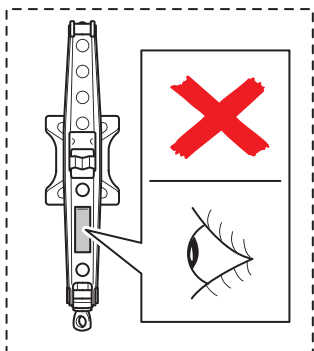

OR

### WITH SPARE WHEEL

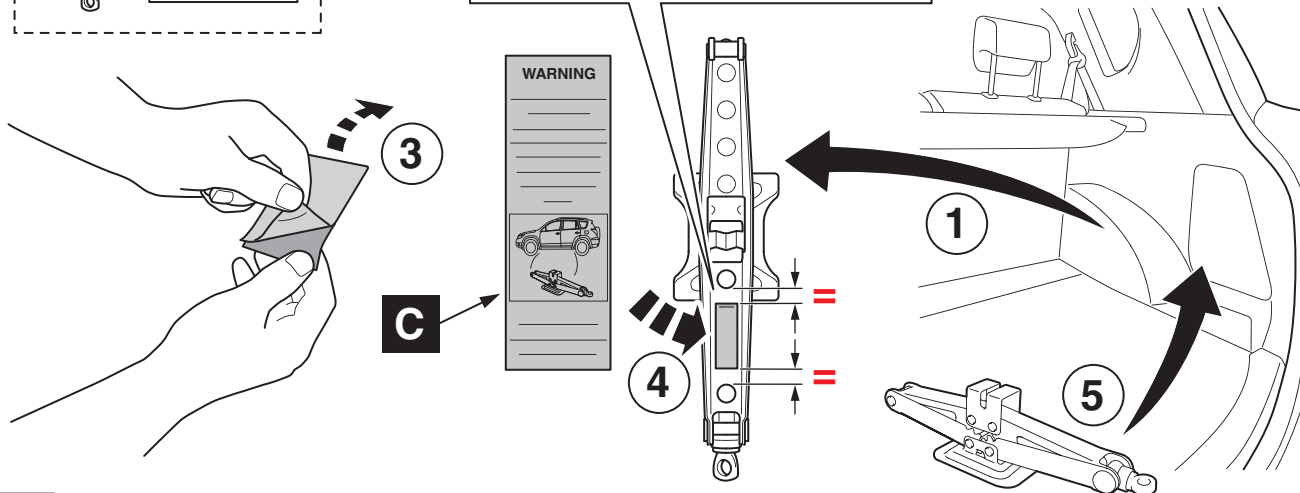
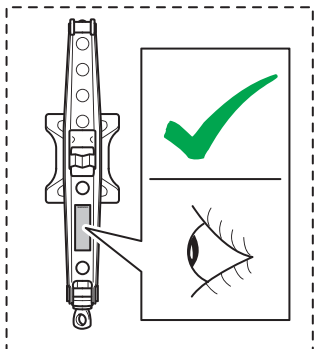

18

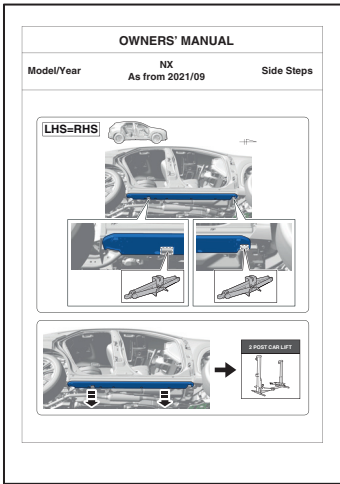

**DISCLAIMER**

<ul style="list-style-type: none"> <li>1. The information in this manual is provided for general information only. It is not intended to be used as a substitute for professional advice.</li> <li>2. The information in this manual is provided for general information only. It is not intended to be used as a substitute for professional advice.</li> <li>3. The information in this manual is provided for general information only. It is not intended to be used as a substitute for professional advice.</li> </ul>	<ul style="list-style-type: none"> <li>4. The information in this manual is provided for general information only. It is not intended to be used as a substitute for professional advice.</li> <li>5. The information in this manual is provided for general information only. It is not intended to be used as a substitute for professional advice.</li> <li>6. The information in this manual is provided for general information only. It is not intended to be used as a substitute for professional advice.</li> </ul>	<ul style="list-style-type: none"> <li>7. The information in this manual is provided for general information only. It is not intended to be used as a substitute for professional advice.</li> <li>8. The information in this manual is provided for general information only. It is not intended to be used as a substitute for professional advice.</li> <li>9. The information in this manual is provided for general information only. It is not intended to be used as a substitute for professional advice.</li> </ul>
--	--	--

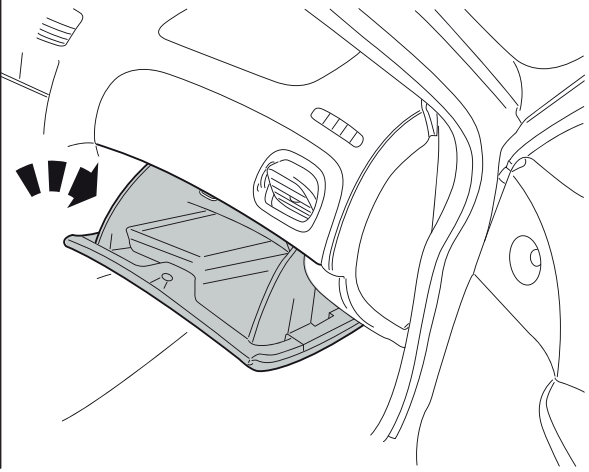

# OWNERS' MANUAL

Model/Year

**NX**  
As from 2021/09

**Side Steps**

**LHS=RHS**

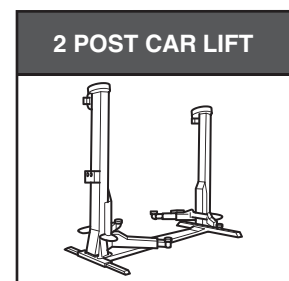
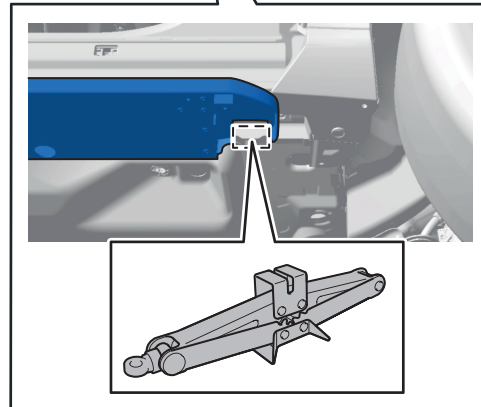
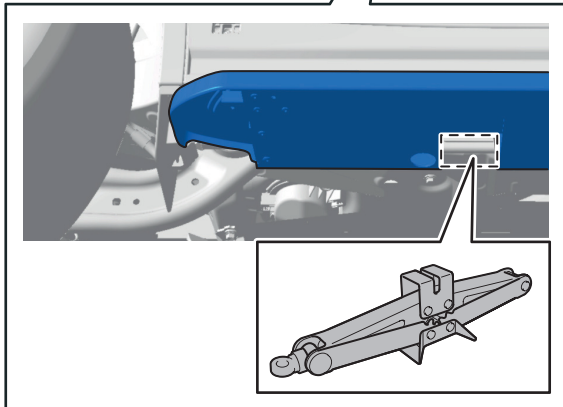



## DISCLAIMER

**EN** Toyota takes no responsibility for damage which is directly or indirectly the result of:

- Jacking the vehicle to the side step.
- Jacking the vehicle incorrectly.

For correct usage of the jack (e.g. in case of a flat tyre), refer to the vehicle owner's manual.

**FR** Toyota n'assume aucune responsabilité pour les dommages qui sont directement ou indirectement le résultat de :

- Levage du véhicule sur le marchepied latéral.
- Levage incorrect du véhicule.

Pour une utilisation correcte du cric (par exemple en cas de pneu crevé), se reporter au manuel d'utilisation du véhicule.

**NL** Toyota neemt geen verantwoordelijkheid voor schade die direct of indirect het gevolg is van:

- Het opkrikken van de auto op de zijtrap.
- Het verkeerd opkrikken van de auto.

Raadpleeg de gebruikershandleiding van de auto voor het juiste gebruik van de krik (bijv. bij een lekke band).

**SV** Toyota tar inget ansvar för skador som direkt eller indirekt är en följd av:

- Jackning av fordonet till sidosteg.
- Att lyfta fordonet på fel sätt.

För korrekt användning av domkraften (t.ex. vid punktering av däck), se fordonets bruksanvisning.

**HU** A Toyota nem vállal felelősséget olyan károkért, amelyek közvetlenül vagy közvetve a következőkből erednek:

- A jármű oldallépcsőre emelése.
- A jármű helytelen felemelése.

Az emelő helyes használatáról (pl. lapos gumibroncs esetén) a jármű használati utasításában olvashat.

**RU** Toyota не несет ответственности за повреждения, которые являются прямым или косвенным результатом:

- Домкратирования автомобиля на боковую подножку.
- Неправильного использования домкрата.

Правильное использование домкрата (например, в случае спущенной шины) описано в руководстве по эксплуатации автомобиля.

**EE** Toyota ei vastuta kahjude eest, mis on otseselt või kaudselt põhjustatud:

- Sõiduki tõstmise tungrauaga küljele.
- Sõiduki vale tõstmise tungrauaga.

Tungraua õige kasutamise kohta (nt rehvi purunemise korral) vaadake sõiduki kasutusjuhendit.

**RO** Toyota nu își asumă responsabilitatea pentru daune care sunt direct sau indirect rezultatul:

- Tragerea vehiculului cu cric pe treapta laterală.
- Cric incorect al vehiculului.

Pentru utilizarea corectă a cricului (de exemplu, în cazul unei anvelope deflate), consultați manualul de utilizare al vehiculului.

**DE** Toyota übernimmt keine Verantwortung für Schäden, die direkt oder indirekt auf Folgendes zurückzuführen sind:

- Aufbocken des Fahrzeugs auf die Trittstufe.
- Unsachgemäßes Anheben des Fahrzeugs.

Die richtige Verwendung des Wagenhebers (z. B. bei einer Reifenpanne) ist in der Betriebsanleitung des Fahrzeugs beschrieben.

**IT** Toyota non si assume alcuna responsabilità per i danni che sono direttamente o indirettamente il risultato di:

- sollevamento del veicolo sul gradino laterale.
- il sollevamento del veicolo in modo non corretto.

Per l'uso corretto del martinetto (ad esempio, in caso di pneumatico sgonfio), consultare il manuale d'uso del veicolo.

**DA** Toyota påtager sig intet ansvar for skader, der direkte eller indirekte er et resultat af:

- Løftning af køretøjet til sidetrinet.
- Løftning af køretøjet på en forkert måde.

For korrekt brug af donkraften (f.eks. i tilfælde af punktering) henvises til køretøjets instruktionsbog.

**FI** Toyota ei ota vastuuta vahingoista, jotka ovat suoraan tai välillisesti seurausta:

- Ajoneuvon nostaminen sivuportaaseen.
- Ajoneuvon tunkkaaminen väärin.

Katso ajoneuvon omistajan käsikirjasta, miten tunkkia käytetään oikein (esim. jos rengas on puhki).

**PL** Toyota nie bierze odpowiedzialności za uszkodzenia, które są bezpośrednio lub pośrednio wynikiem:

- Podnoszenia pojazdu na stopień boczny.
- Nieprawidłowego użycia podnośnika.

Prawidłowe użycie podnośnika (np. w przypadku przebicia opony) znajduje się w instrukcji obsługi pojazdu.

**TR** Toyota, doğrudan veya dolaylı olarak aşağıdakilerden kaynaklanan hasarlar için sorumluluk kabul etmez:

- Aracın yan basamağa krik ile çekilmesi.
- Aracın yanlış krik ile kaldırılması.

Krikonun doğru kullanımı için (örn. lastik patlaması durumunda) aracın kullanım kılavuzuna bakın.

**LV** Toyota neuzņemas atbildību par bojājumiem, kas tieši vai netieši radušies:

- Transportlīdzekļa pacelšana uz sānu pakāpiena.
- Nepareiza automašīnas pacelšana ar domkratu.

Lai uzzinātu, kā pareizi lietot domkratu (piemēram, pārsista riepa), skatiet transportlīdzekļa īpašnieka rokasgrāmatu.

**SI** Toyota ne prevzema odgovornosti za škodo, ki je neposredno ali posredno posledica:

- dvigovanje vozila na stransko stopnico.
- nepravilnega dvigovanja vozila.

Za pravilno uporabo dvigala (npr. v primeru prazne pnevmatike) glejte navodila za uporabo vozila.

**ES** Toyota no se hace responsable de los daños que sean consecuencia directa o indirecta de:

- Levantar el vehículo con el gato en el escalón lateral.
- El uso incorrecto del gato del vehículo.

Para el uso correcto del gato (por ejemplo, en caso de un neumático pinchado), consulte el manual del propietario del vehículo.

**PT** A Toyota não assume qualquer responsabilidade por danos que sejam directa ou indirectamente o resultado dos mesmos:

- Levantar o veículo para o degrau lateral.
- Acoplar o veículo de forma incorrecta.

Para uma utilização correcta do macaco (por exemplo, no caso de um pneu furado), consultar o manual do proprietário do veículo.

**NO** Toyota tar intet ansvar for skade som er direkte eller indirekte et resultat av:

- Jekke kjøretøyet til sidetrinnet.
- Jekking av kjøretøyet feil.

For riktig bruk av jekken (f.eks. i tilfelle et flatt dekk), se kjøretøyet's brukerhåndbok.

**CS** Společnost Toyota nenese žádnou odpovědnost za škody, které vznikly přímo nebo nepřímo v důsledku:

- zvednutí vozidla na boční schůdek.
- nesprávného zvednutí vozidla.

Informace o správném použití zvedáku (např. v případě defektu pneumatiky) naleznete v návodu k obsluze vozidla.

**EL** Η Toyota δεν φέρει καμία ευθύνη για ζημιές που είναι άμεσα ή έμμεσα αποτέλεσμα:

- Ανυψώνοντας το όχημα στο πλαϊνό σκαλοπάτι.
- Ανυψώνοντας το όχημα με λανθασμένο τρόπο.

Για τη σωστή χρήση του γρύλου (π.χ. σε περίπτωση σκαμένου ελαστικού), ανατρέξτε στο εγχειρίδιο χρήσης του οχήματος.

**BG** Toyota не носи отговорност за щети, които са пряк или косвен резултат от:

- забиване на автомобила в страничното стъпало.
- Неправилно повдигане на автомобила.

За правилната употреба на крика (напр. при спукана гума) вижте ръководството за експлоатация на автомобила.

**LT** „Toyota“ neprisiima atsakomybės už žalą, kurią tiesiogiai ar netiesiogiai sukėlė:

- Automobilio pakėlimas ant šoninio laiptelio.
- Neteisingai pakelkite automobilį.

Kaip teisingai naudoti domkratą (pvz., nuleista padanga), žr. transporto priemonės savininko vadovą.

**SK** Toyota nenesie žiadnu zodpovednosť za škody, ktoré sú priamo alebo nepriamo výsledkom:

- Zdvíhnutie vozidla na bočný schodík.
- Nesprávne zdvihnutie vozidla.

Pre správne používanie zdviháka (napríklad v prípade defektu pneumatiky) si pozrite návod na obsluhu vozidla.



Model / Year **LEXUS NX**  
As from 2021/09



Side Steps

VIN n°



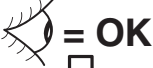
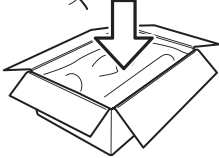

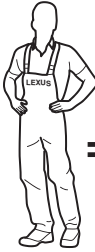
## DURING INSTALLATION

**1**



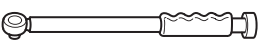

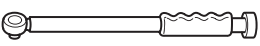
 = OK  
  
 P/N = OK

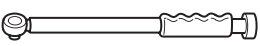
 = A  
 = B

**2**

		Serial Number	
		N° 1	<input style="width: 100%;" type="text"/>
		N° 2	<input style="width: 100%;" type="text"/>
		N° 3	<input style="width: 100%;" type="text"/>

**3**



 9x  

RHS

LHS

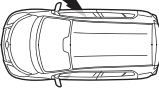
RHS



LHS

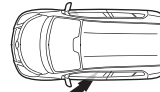

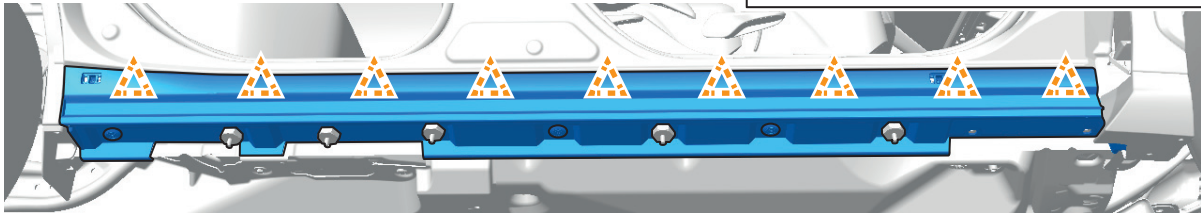

# CHECK SHEET Page 2 of 3

## DURING INSTALLATION

**RHS** **LHS**

**5x** **5x 45 Nm** **RHS** **LHS**

**4**

## AFTER INSTALLATION

**RHS** **LHS**

**5x** **5x 24 Nm** **A B** **A B** **RHS** **LHS**

**1**

# CHECK SHEET Page 3 of 3

## AFTER INSTALLATION

**RHS**

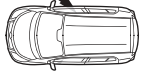

**LHS**

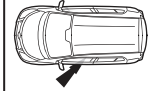

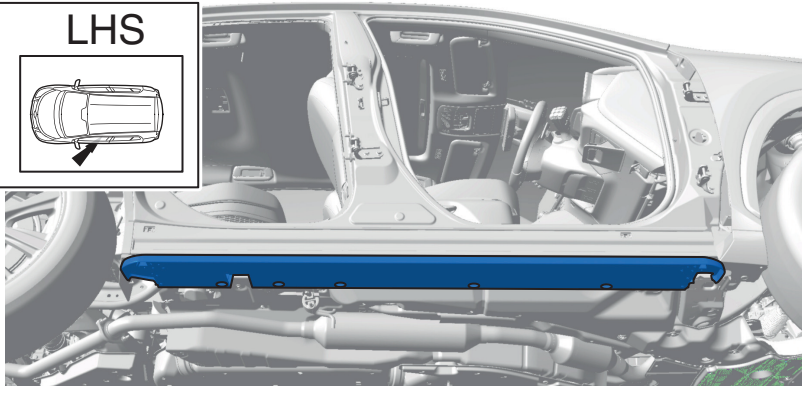



**= OK**

2

**OWNERS' MANUAL**

Model/Year: NX As from 2021/09 Side Steps

**LHS=RHS**

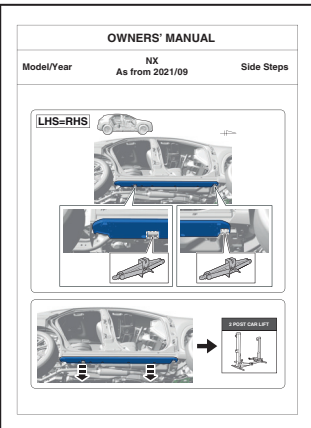

**DISCLAIMER**

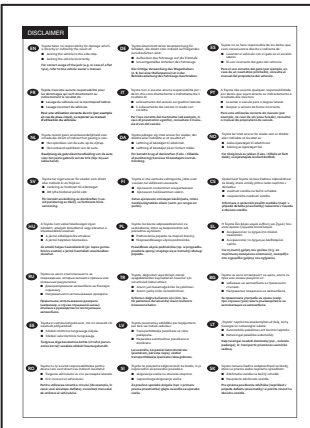

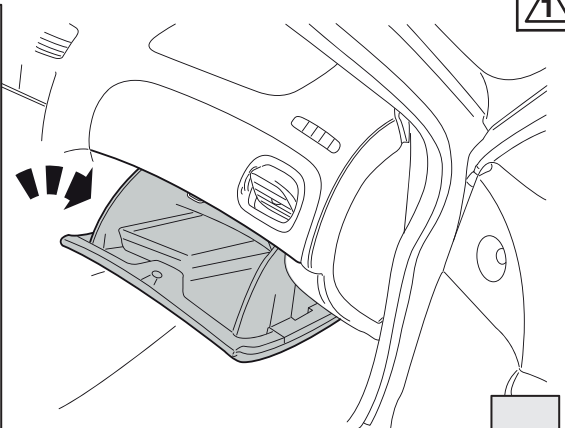

3

**WITH TIRE REPAIR KIT**

**WARNING**



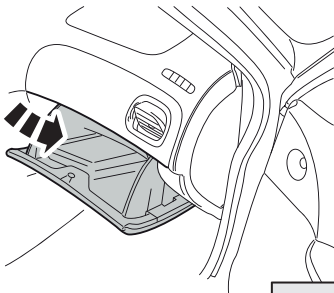



**OR**

**WITH SPARE WHEEL**

**WARNING**

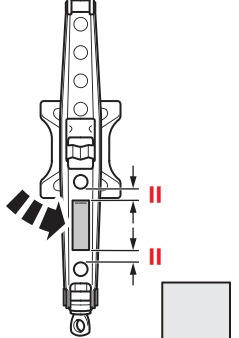





**= OK**

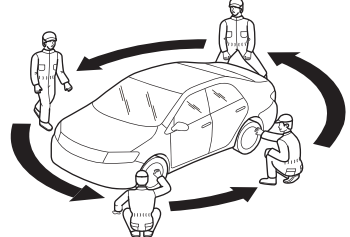



**= OK**

5

**Installation Date:**

\_\_\_\_/\_\_\_\_/\_\_\_\_

**Technician Name & Signature:**

\_\_\_\_\_

**Stamp:**

\_\_\_\_\_