

Yaris Hybrid

N1Kit TDK with Steel Separator

Installation instructions

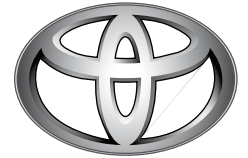

TOYOTA

ALWAYS A
BETTER WAY



Model year: 2013
Vehicle code: NHP130L-CHX*BW
Part number: PZ449-B2E32-00
Weight: 34,4 kg

Manual reference number: AIM 002 891-0

Revision Record

| Rev nr | Date | Page | Picture | Update | New | Deleted steps |
|--------|------|------|---------|--------|-----|---------------|
| | | | | | | |
| | | | | | | |
| | | | | | | |
| | | | | | | |
| | | | | | | |

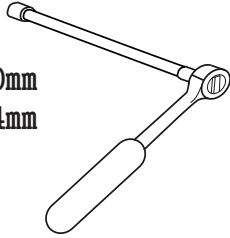
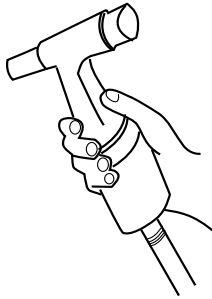
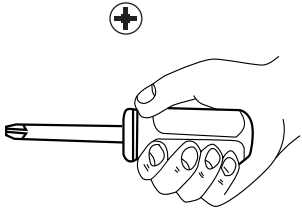

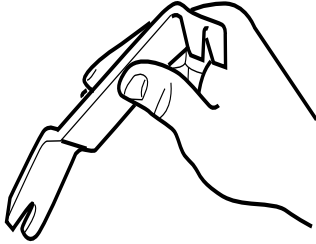
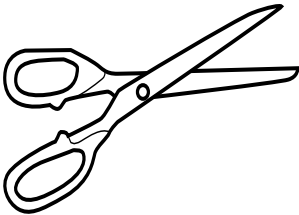
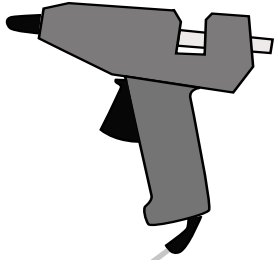
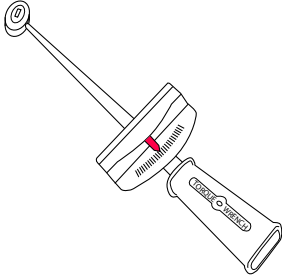
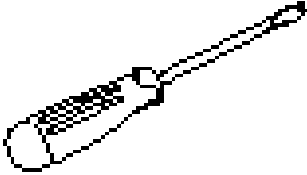
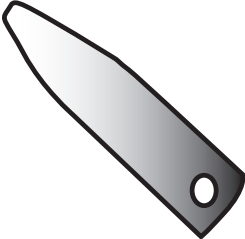
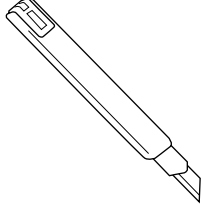
Tools

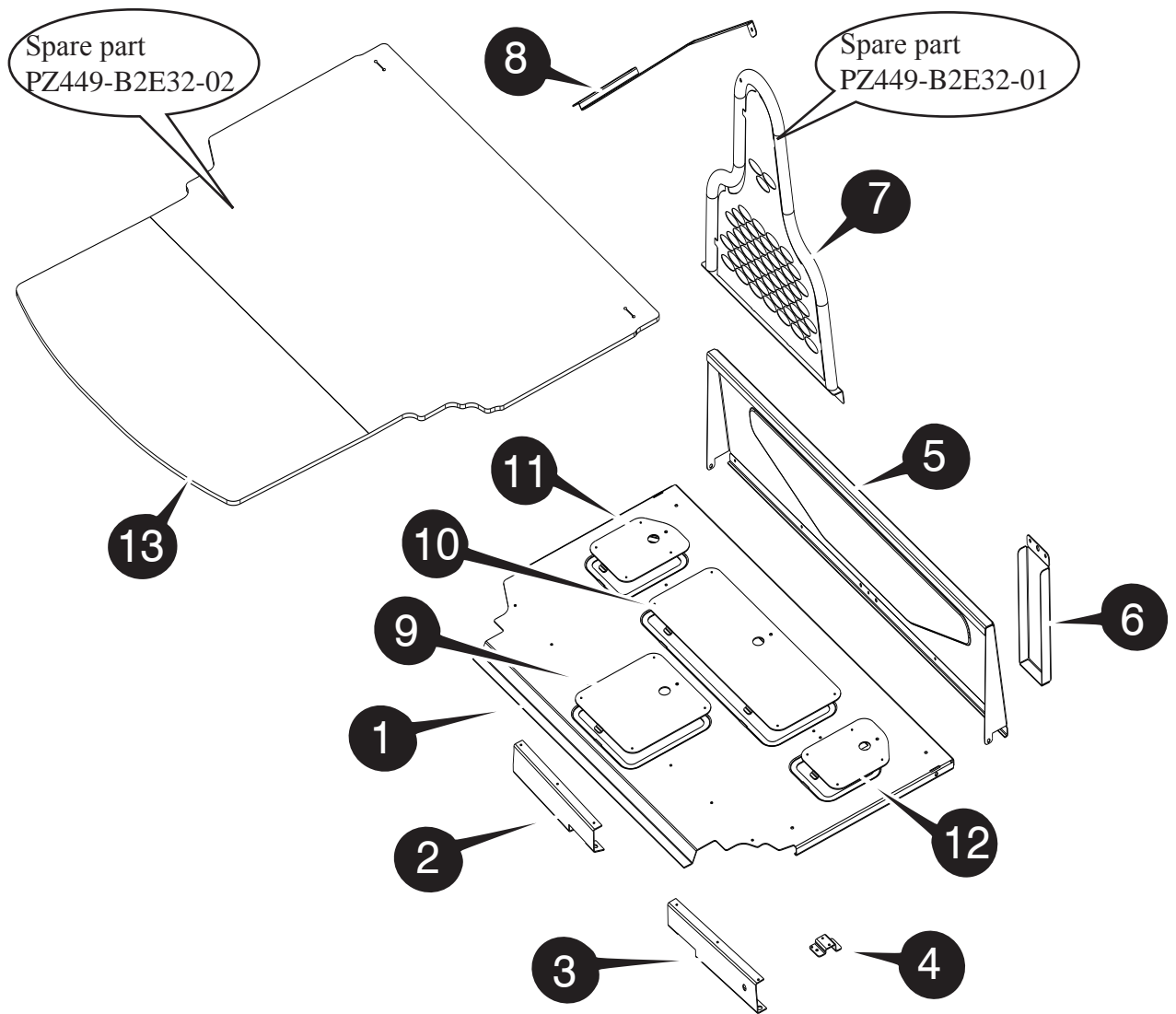
| | | | |
|---|---|--|---|
|  | <p>10mm 14mm</p>  |  | <p>+</p>  |
| <p>10mm</p>  |  |  |  |
|  | <p>-</p>  |  |  |
| | | | |

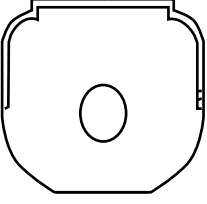

| BOM: 15007480 | | | |
|---------------|----------|-------------|-------------------------|
| Number | Quantity | Part Number | Definition |
| 1 | 1 | 15007481 | Front Floor |
| 2 | 1 | 15007482 | Floor Support LH |
| 3 | 1 | 15007483 | Floor Support RH |
| 4 | 2 | 15007484 | Floor Spacer |
| 5 | 1 | 15007485 | Lower Seperator |
| 6 | 1 | 15007486 | Floor Support Front |
| 7 | 1 | 15007487 | Half Top Tube Separator |
| 8 | 1 | 15007491 | Handle Bracket Left |
| 9 | 1 | 15007492 | Floor Hatch Fuelpump |
| 10 | 1 | 15007493 | Floor Hatch Middle |
| 11 | 1 | 15007494 | Floor Hatch LH |
| 12 | 1 | 15007495 | Floor Hatch RH |
| 13 | 1 | 15007496 | Full Carpet Floor |

Spare part - PZ449-B2E32-60

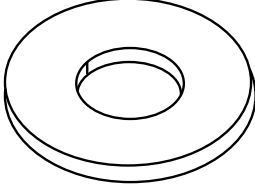
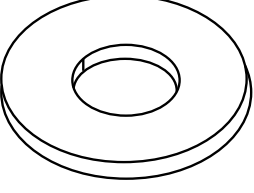
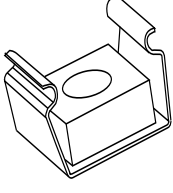
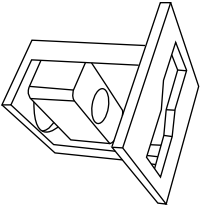
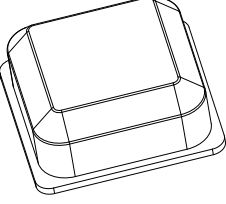
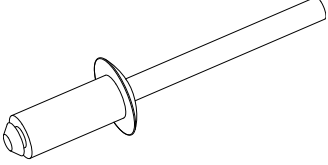
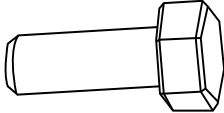
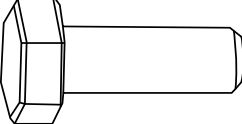
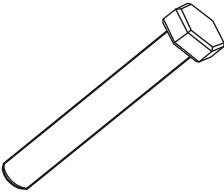
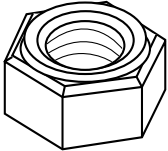
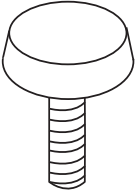
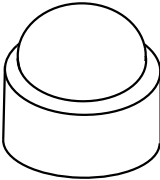
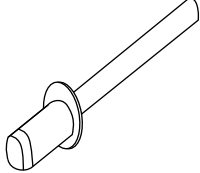
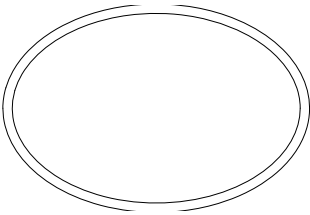
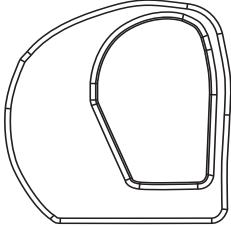
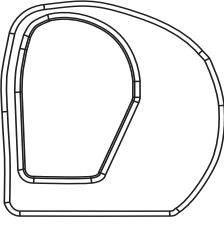
| | | |
|--|---|--|
| <p>1. A 500252 2 PCS</p>  | <p>2. A 500250 2 PCS</p>  | <p>3. A 6,4x15x1,5 12 PCS</p>  |
| <p>4. A 6,4x15x1,5 S 16 PCS</p>  | <p>5. A 123-M6-2C ZC 6 PCS</p>  | <p>6. A MP 8236A 2 PCS</p>  |
| <p>7. A 225 085 6515 4 PCS</p>  | <p>8. A 15007499 2 PCS</p>  | <p>9. A 6x16 6K 7 PCS</p>  |
| <p>1. B 6x20 6K 8 PCS</p>  | <p>2. B 6x45 6K 1 PCS</p>  | <p>3. B 6 NMU 12 PCS</p>  |
| <p>4. B M6x20 Rattskrue 4 PCS</p>  | <p>5. B 221 M06SW10 S 13 PCS</p>  | <p>6. B 5x12 NSS 15 PCS</p>  |
| <p>7. B 05-97062 2 PCS</p>  | <p>8. B 15004855 1 PCS</p>  | <p>9. B 15004856 1 PCS</p>  |

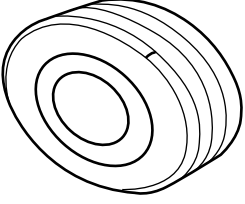
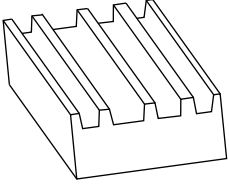
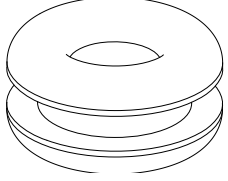
| | | |
|---|--|---|
| 1. C 561 528 2 PCS  | 2. C 36.721004 6m  | 3. C 042 0601 02 PCS  |
| | | |

To be ordered separately in case of power window

Spare part - PZ449-B2E31-03

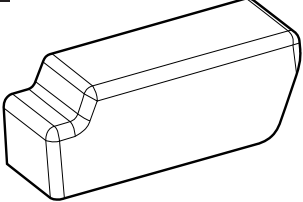
| | | |
|--|--|--|
| 1. D 05100973 2 PCS  | | |
| | | |

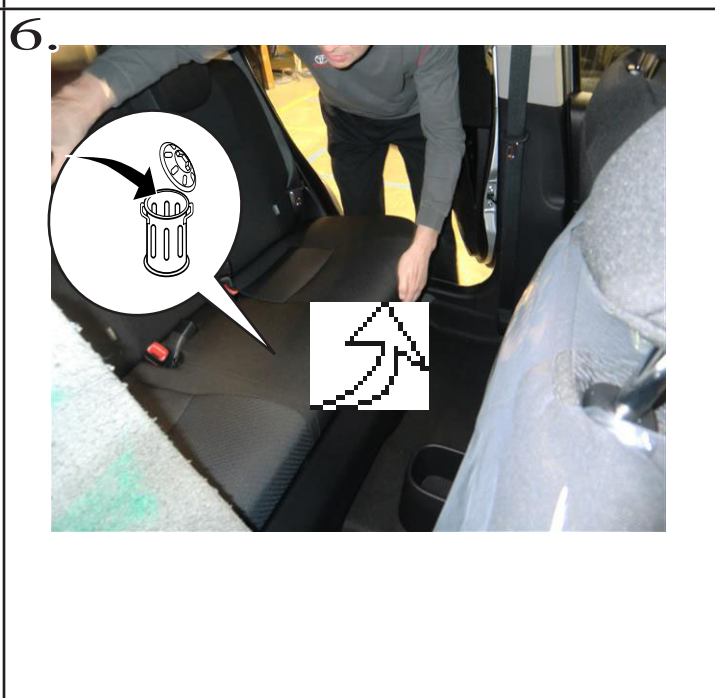
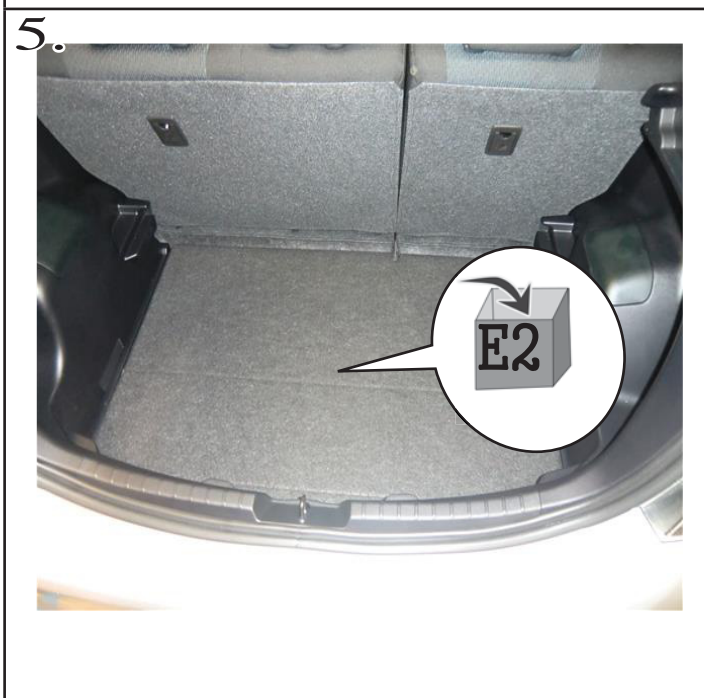
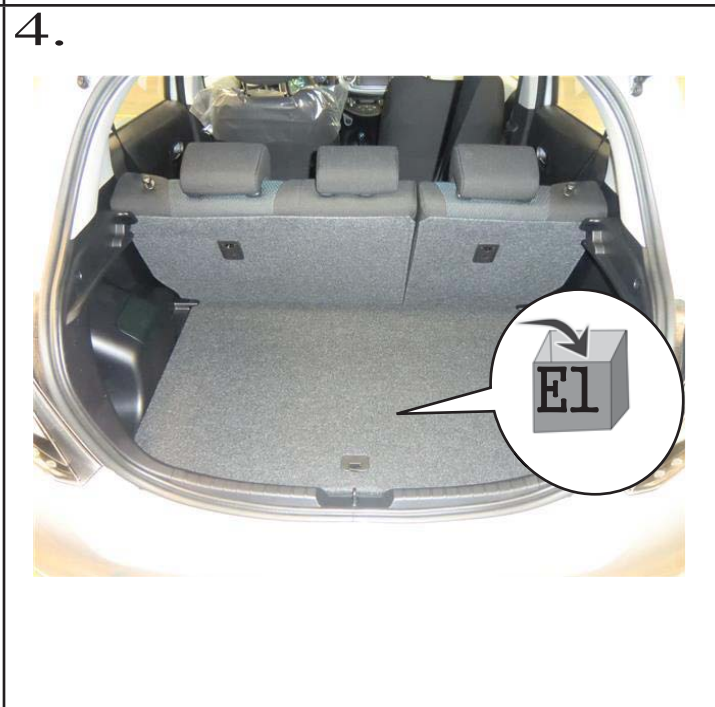
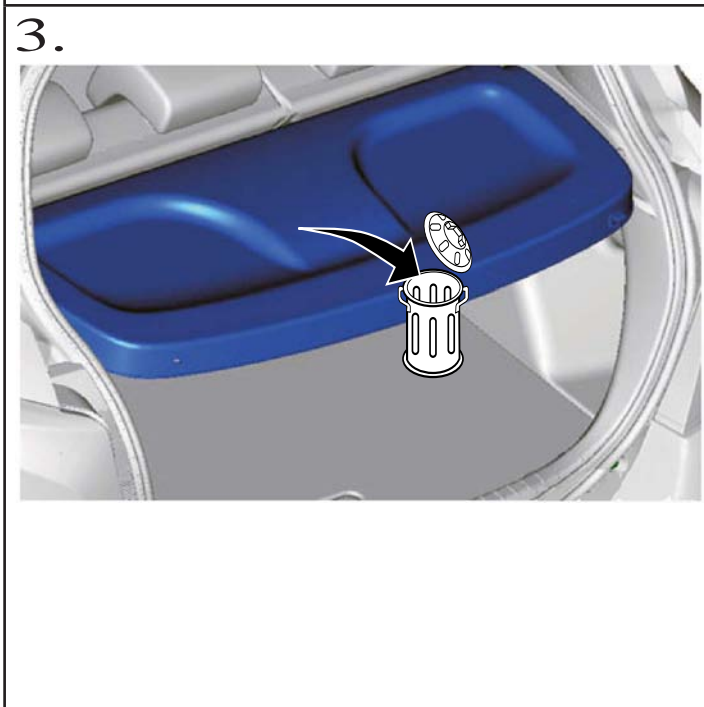
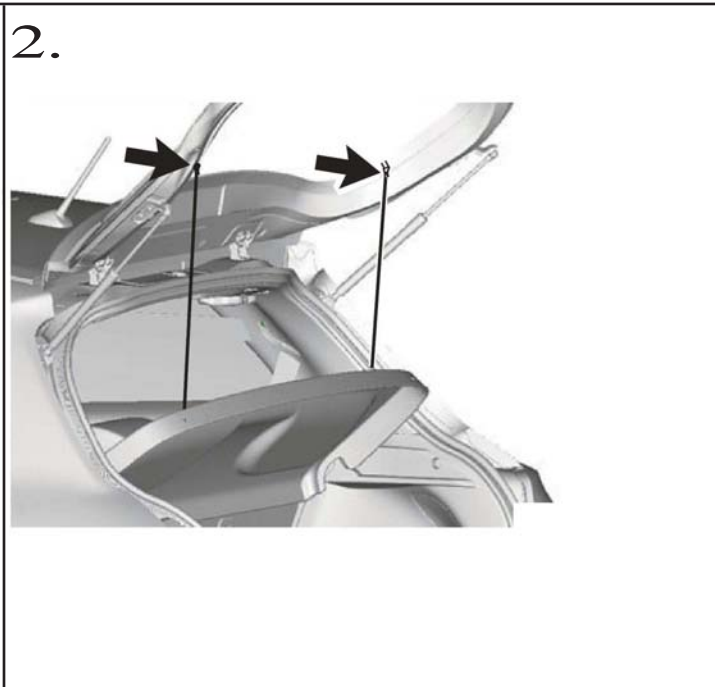
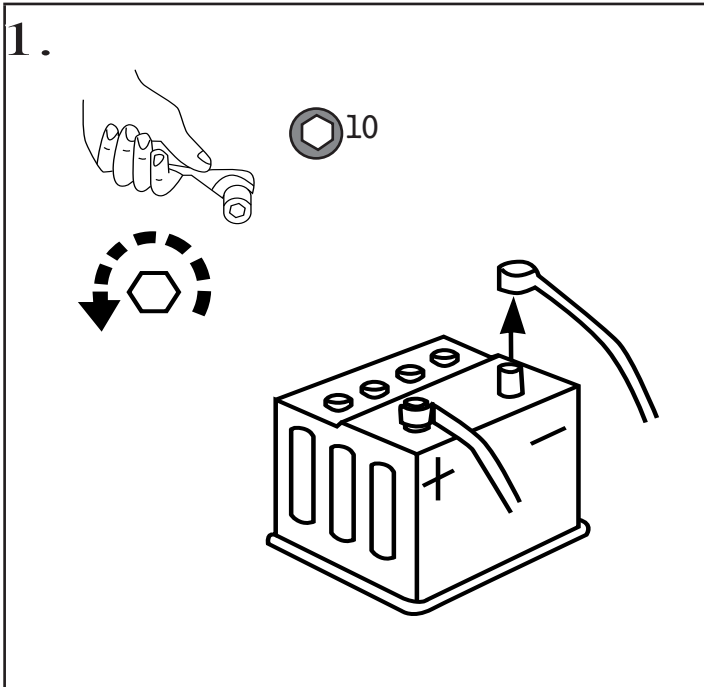

7.



8.

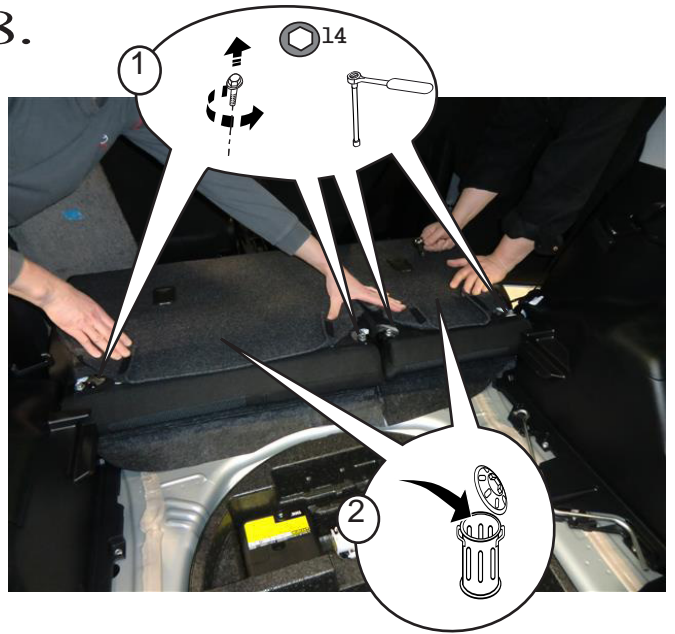

9.

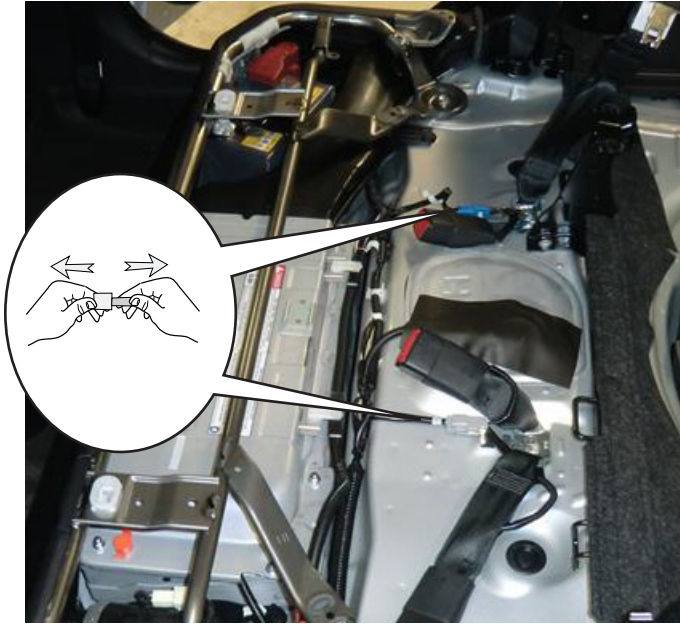

10.

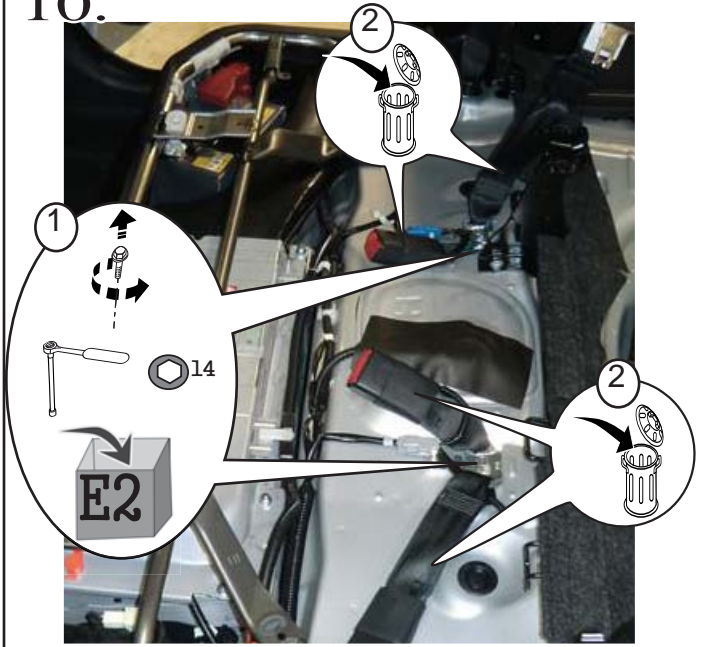

11.

L&R



12.

L&R

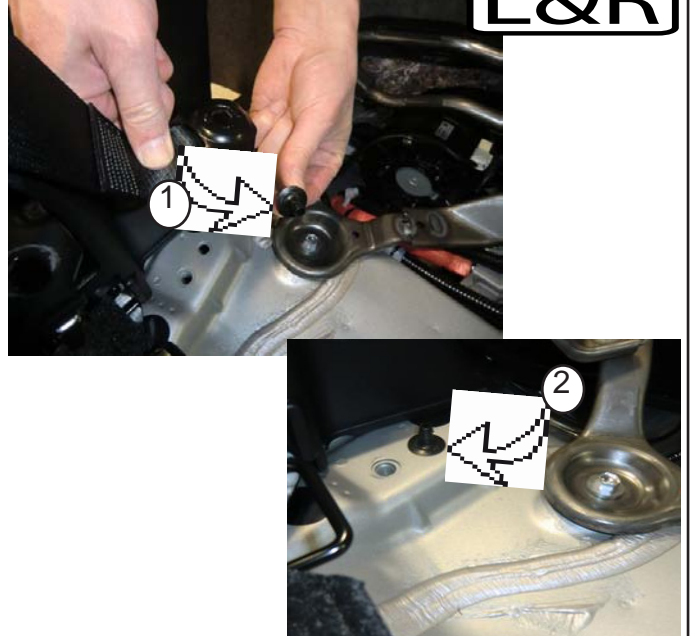

13.

L&R

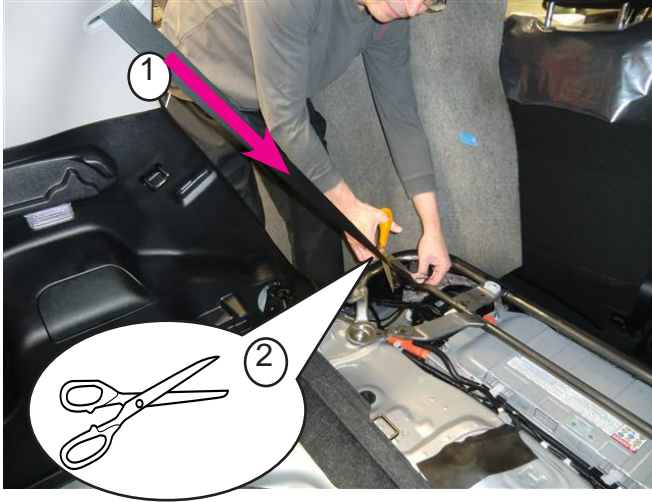

14.

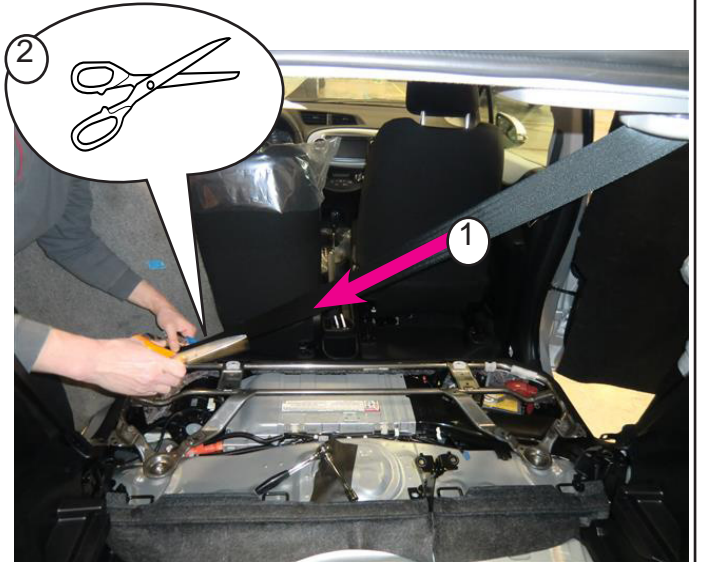

15.

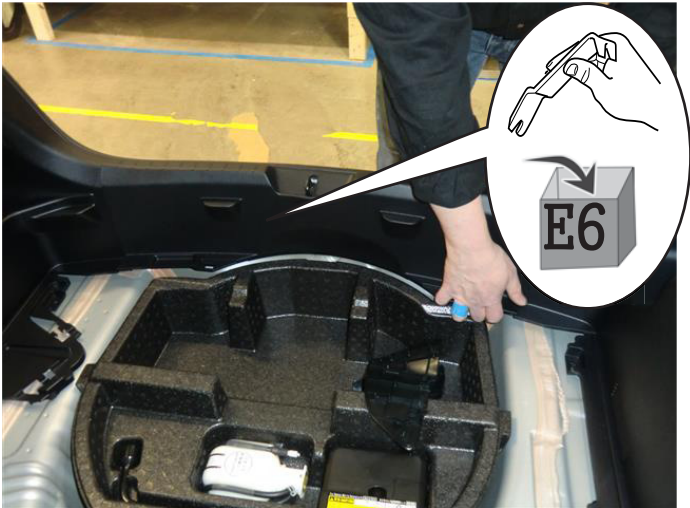

16.

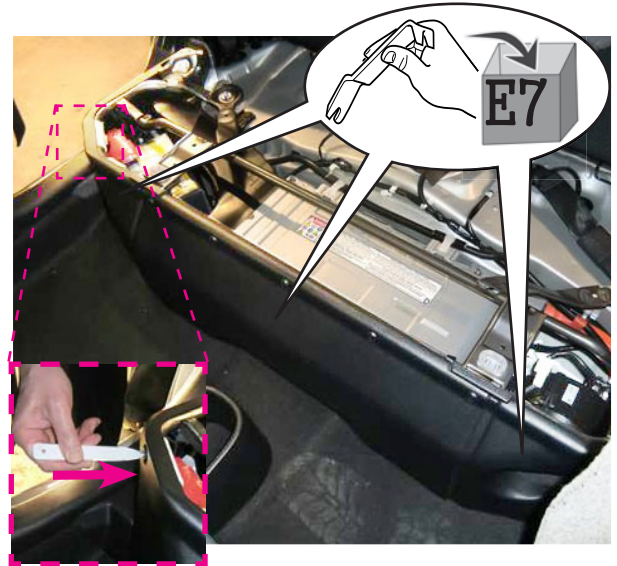

17.

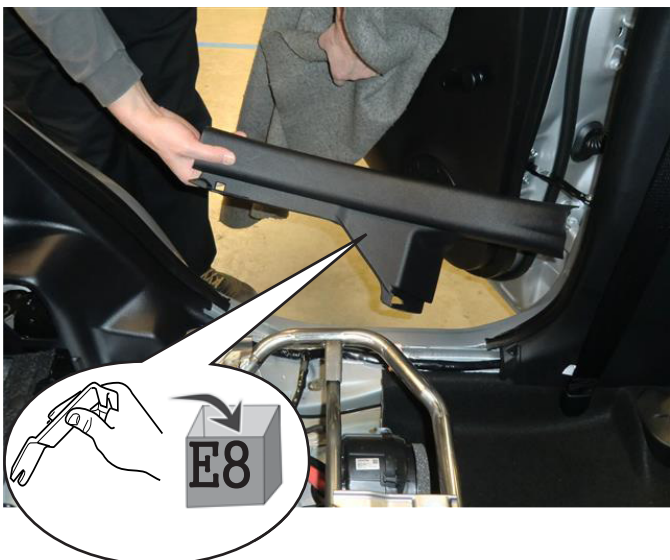

18.

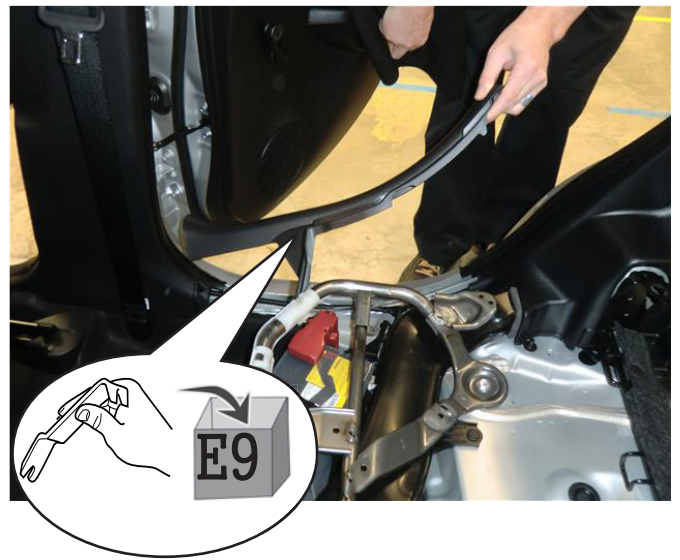

19.

L&R

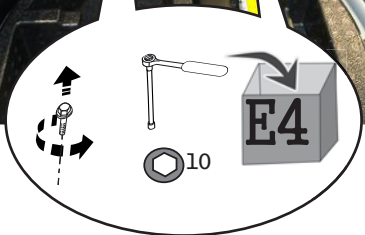
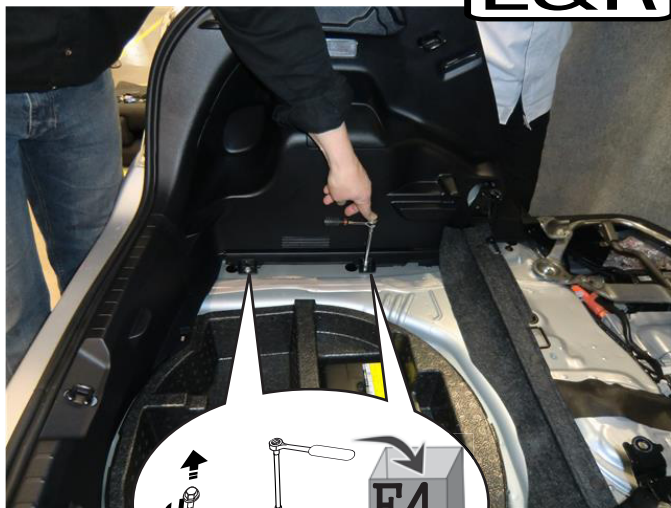

20.

L&R



21.



22.

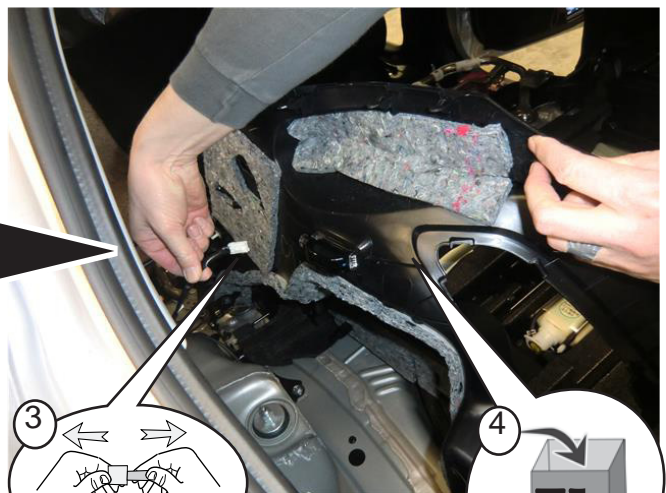

23.



24.

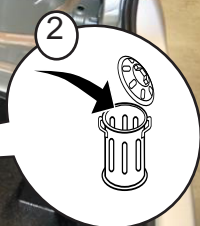
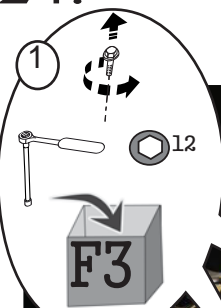
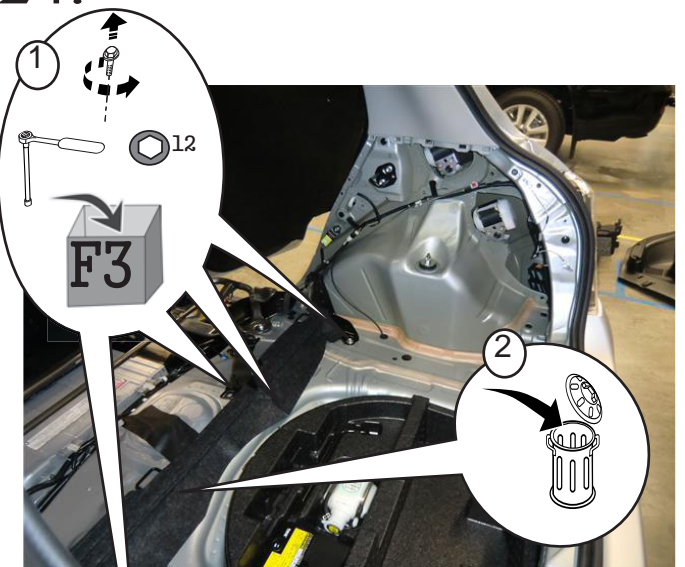

25.

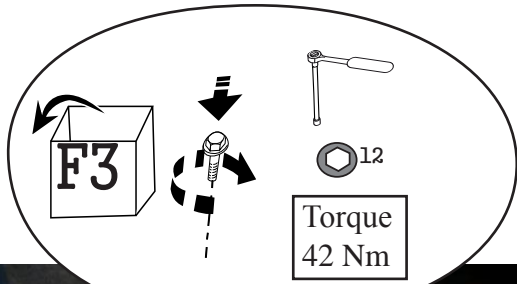

26.

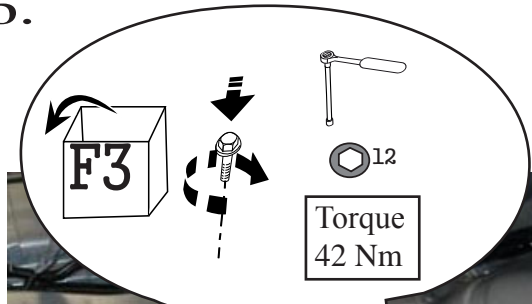

27.



28.



29.

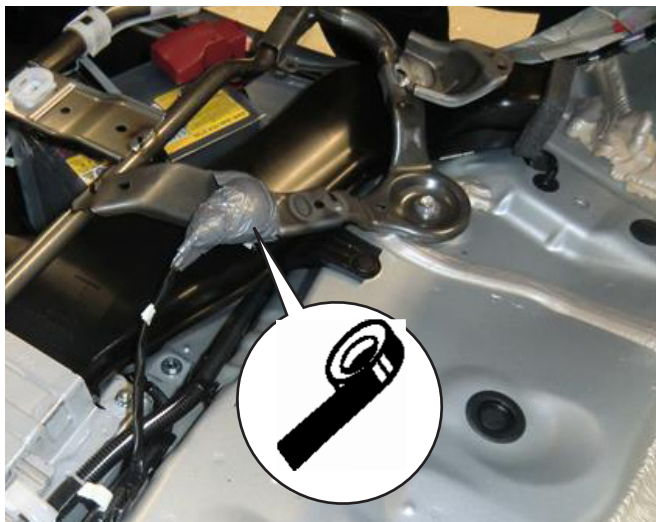

30.



31.



32.



33.



34.



35.

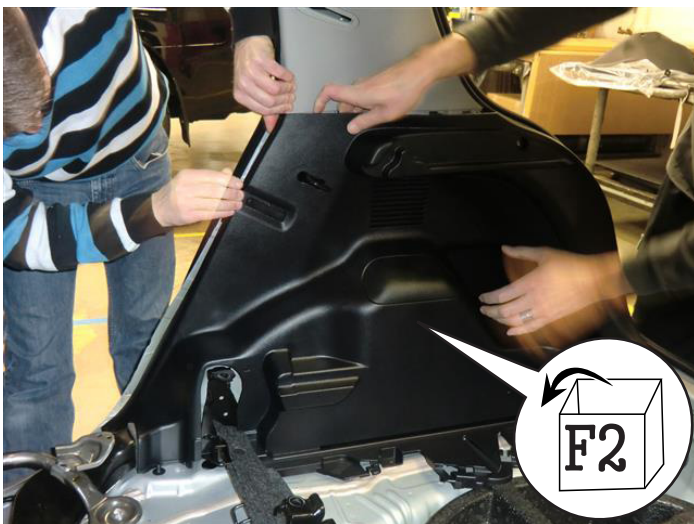

36.

L&R

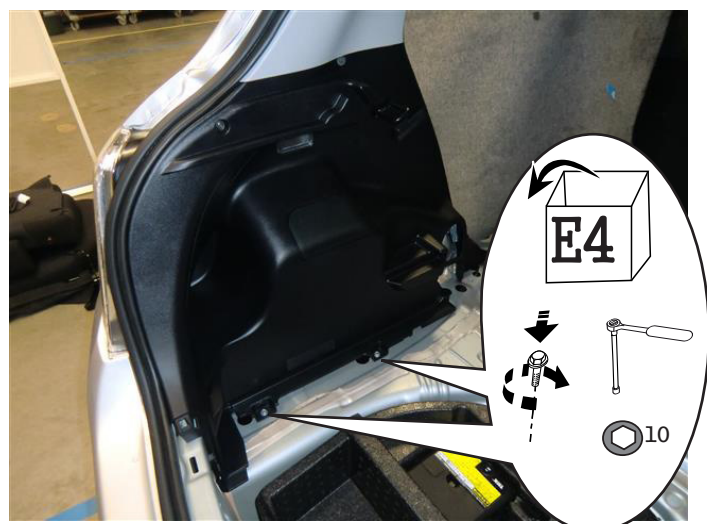

37.

L&R



38.

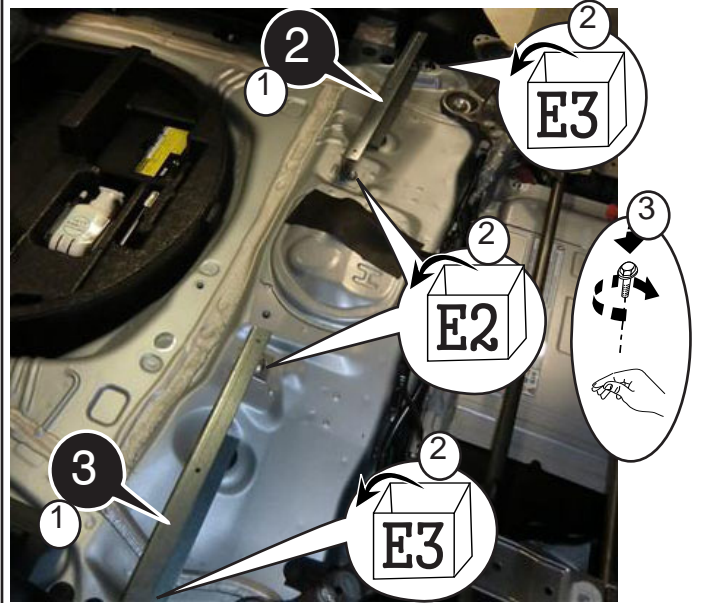

39.

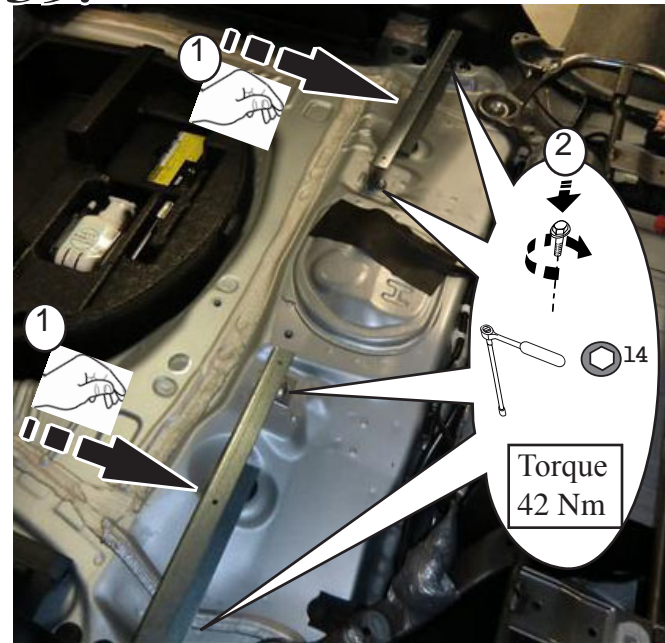

40.

L&R

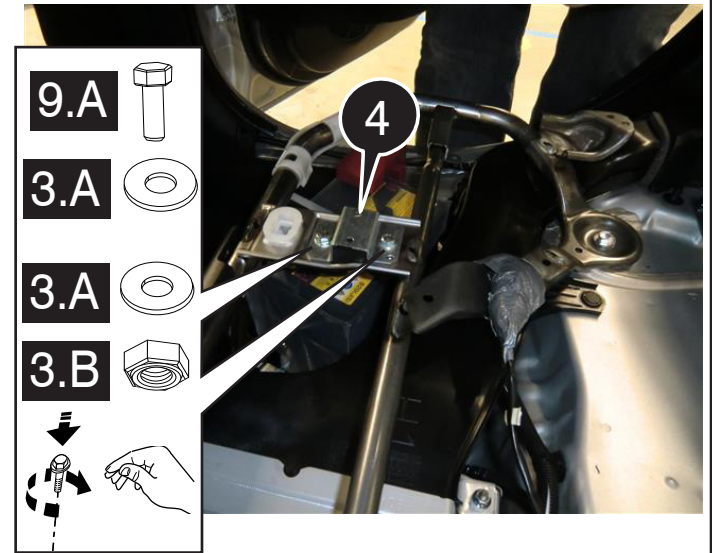

41.

L&R

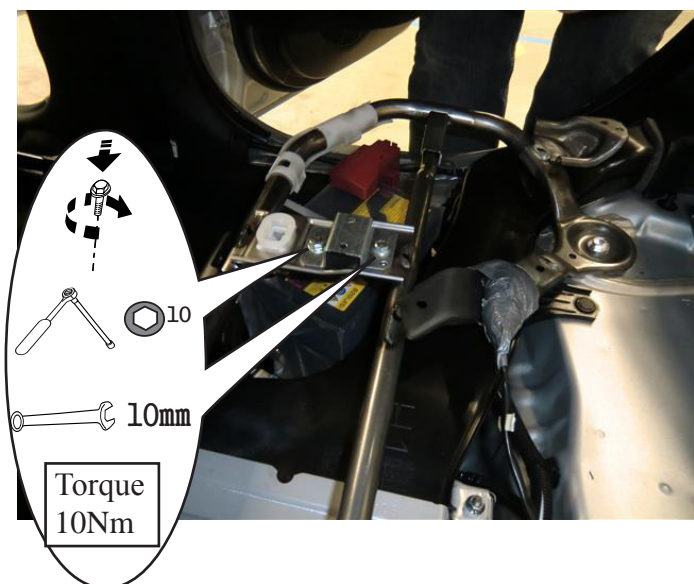

42.

L&R

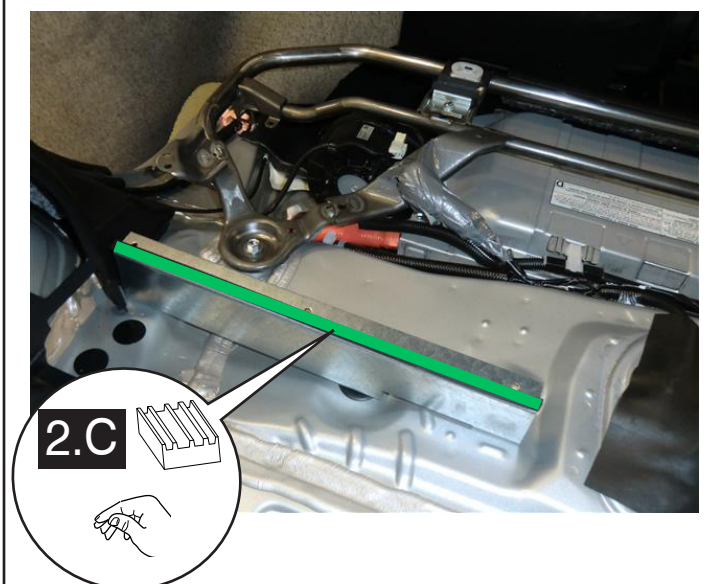

43.

L&R

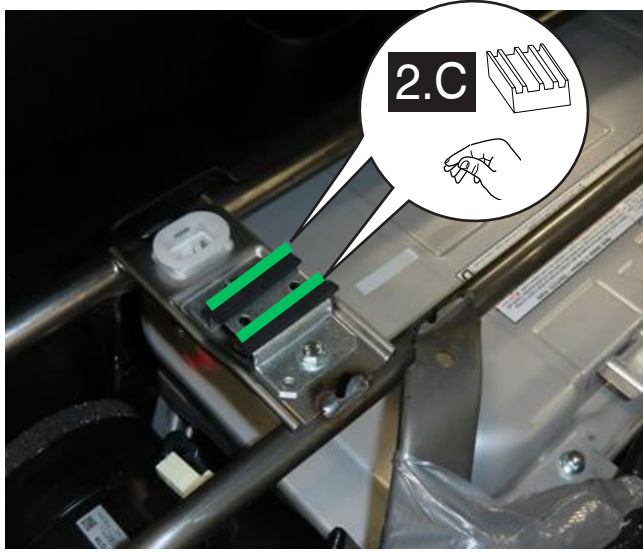

44.

L&R

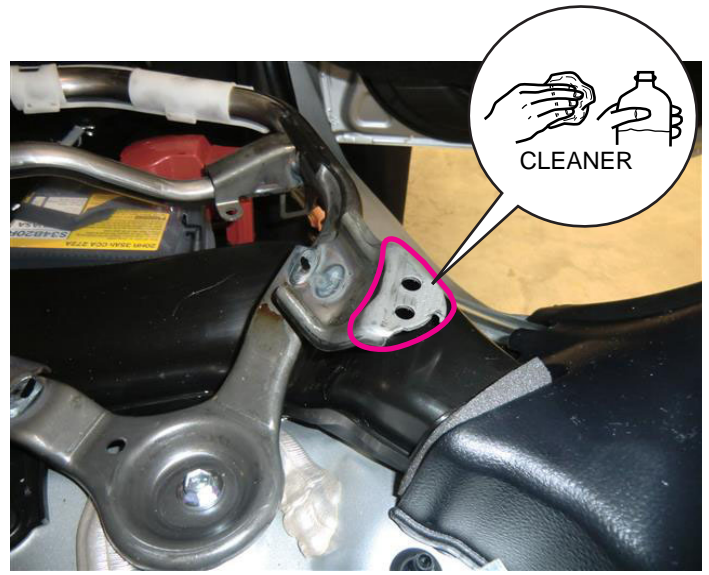

45.

L&R

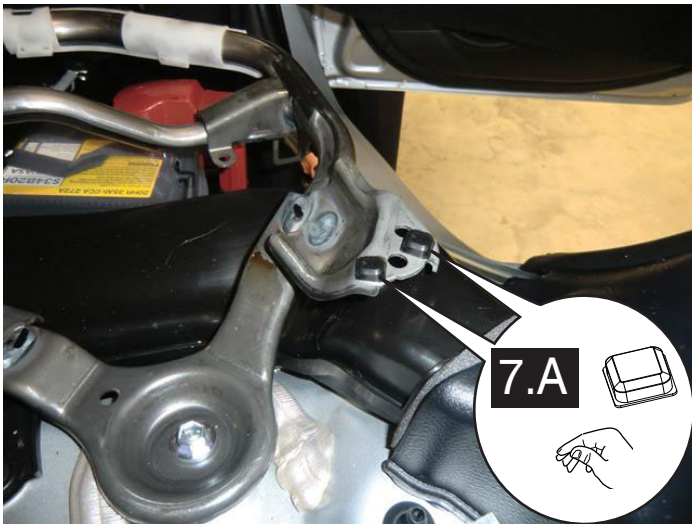

46.

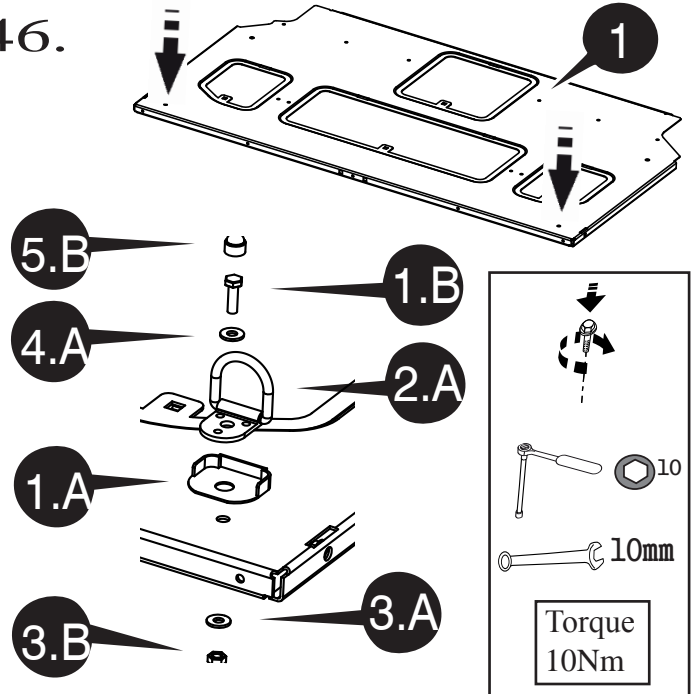

47.

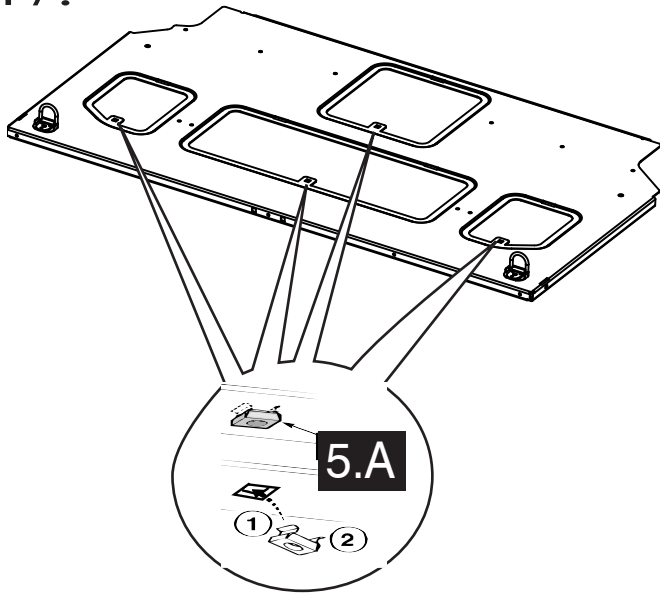

48.

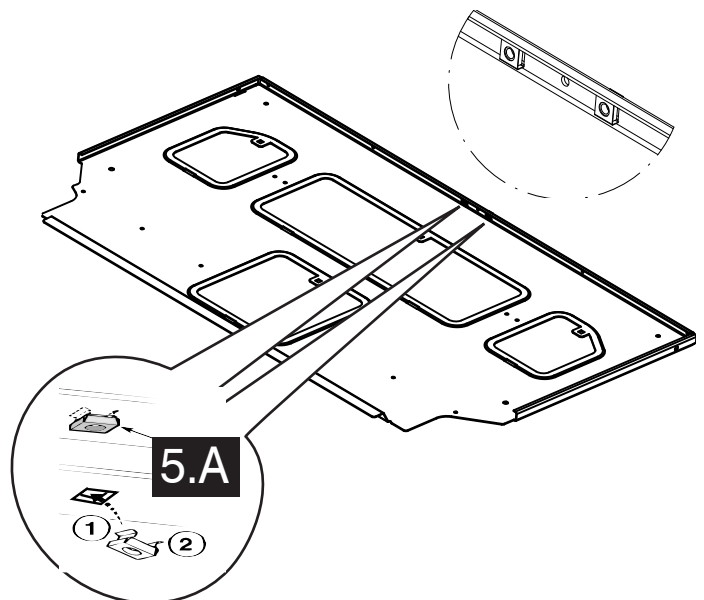

49.

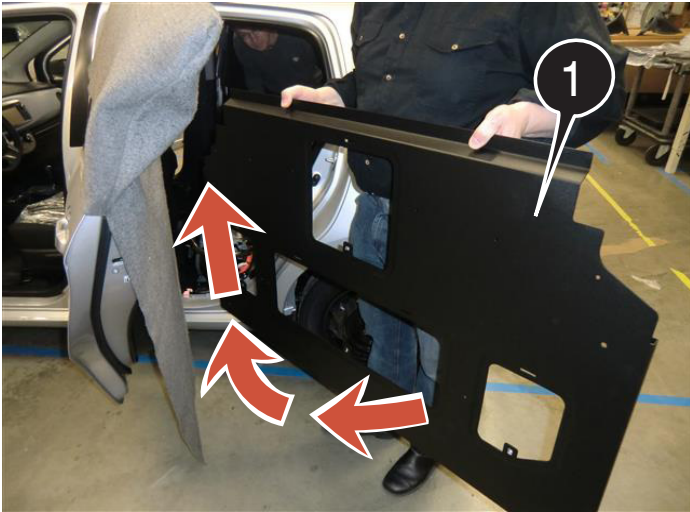

50.

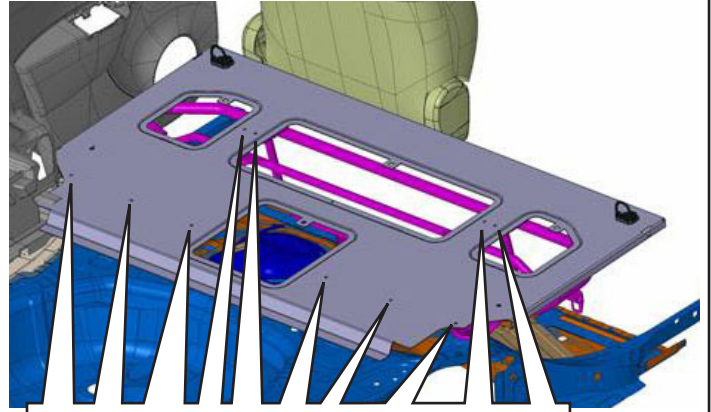

6.B



10 pcs

51.

8.A



2 pcs

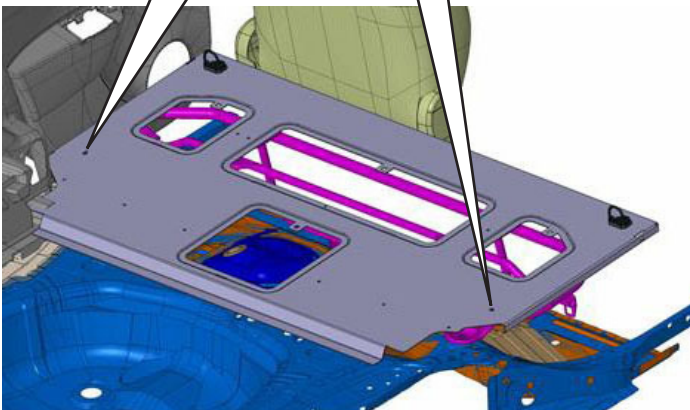

52.

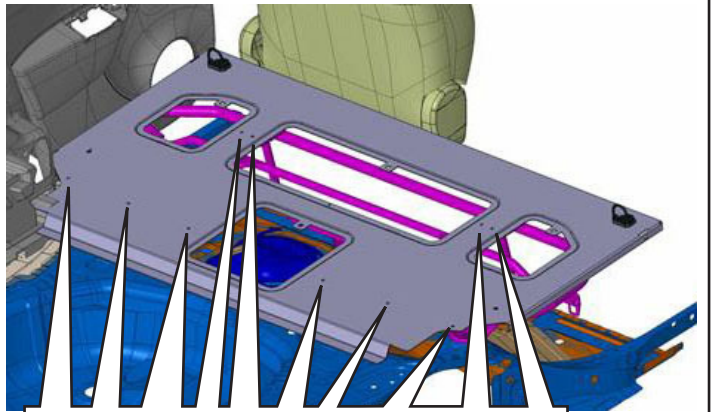

10 pcs

53.

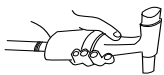

2 pcs

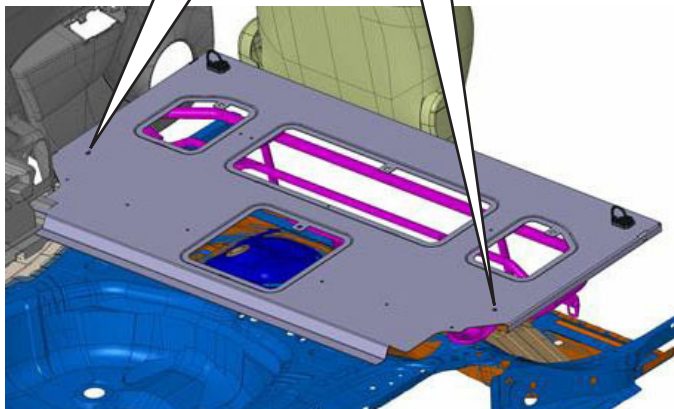

54.

L&R

5

1.B



4.A



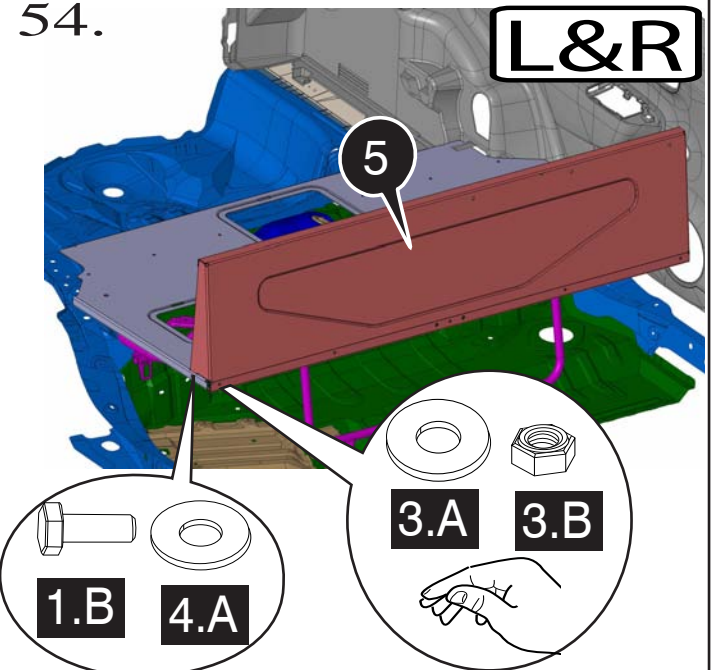

3.A

3.B

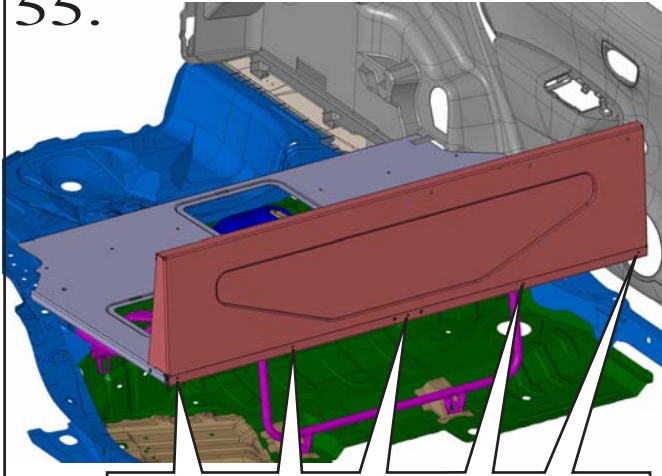

55.





6.B  
5 pcs

56.

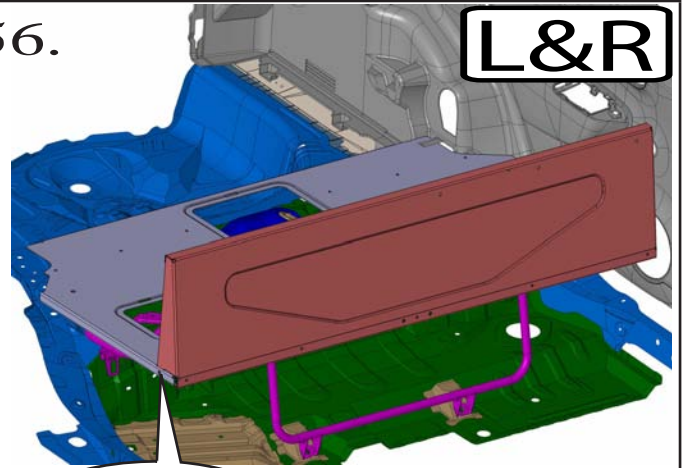
L&R



 
10mm
 **Torque**
10Nm

57.



58.





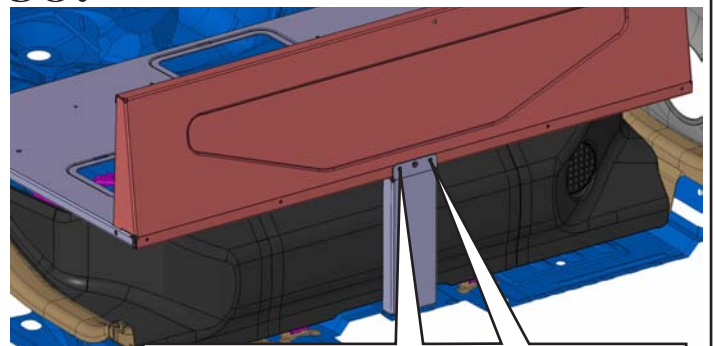

59.

E7 
7 pcs

60.

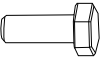
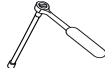

   
3.B **3.A** **4.A** **1.B**
 
 10mm **Torque**
10Nm 2 pcs

61.

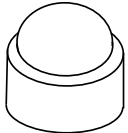
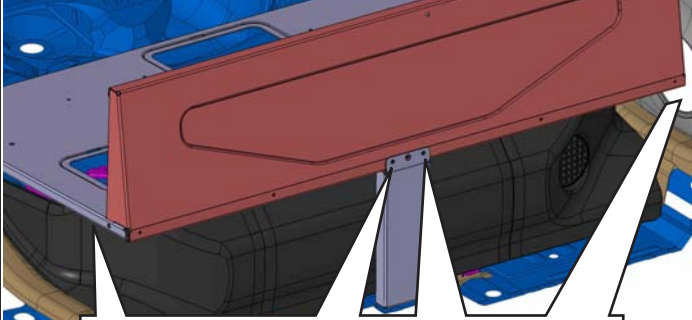

5.B



4 pcs

62.

L&R

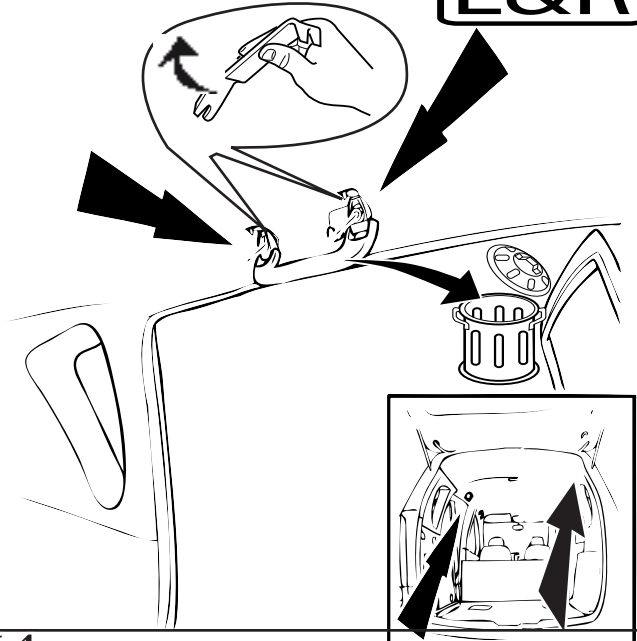

63.

64.

L

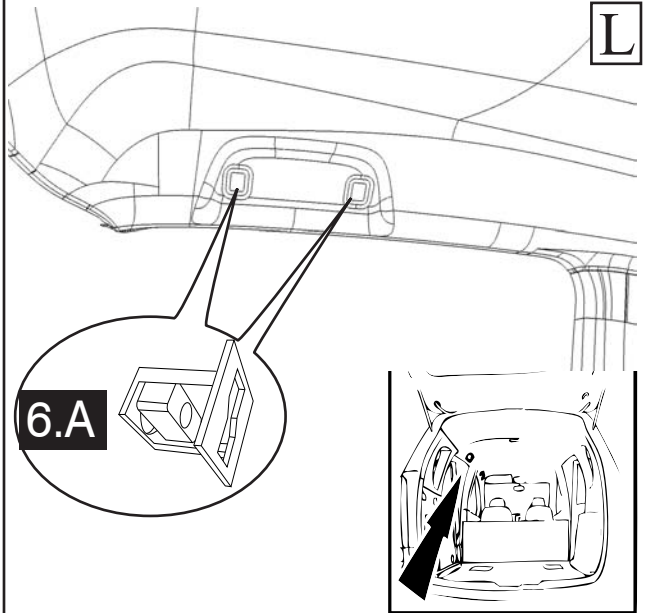

6.A

65.

L

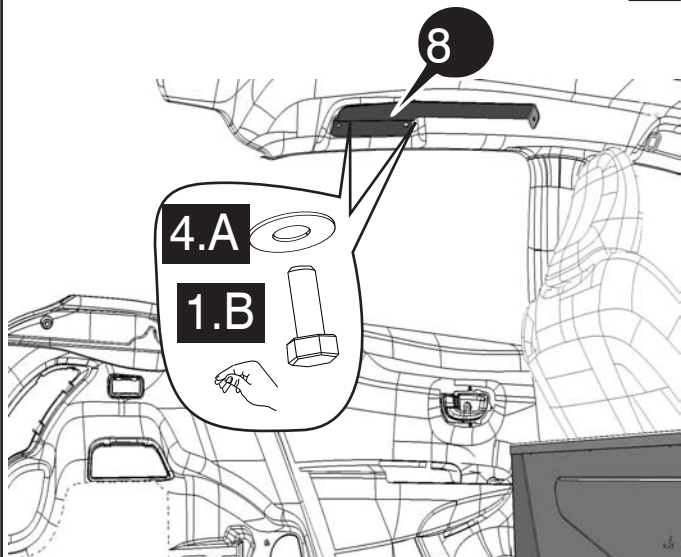

4.A

1.B

8

66.

R

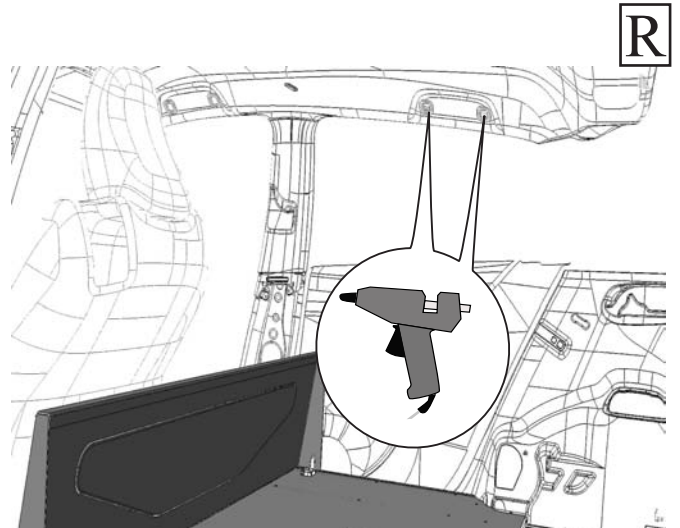

67.

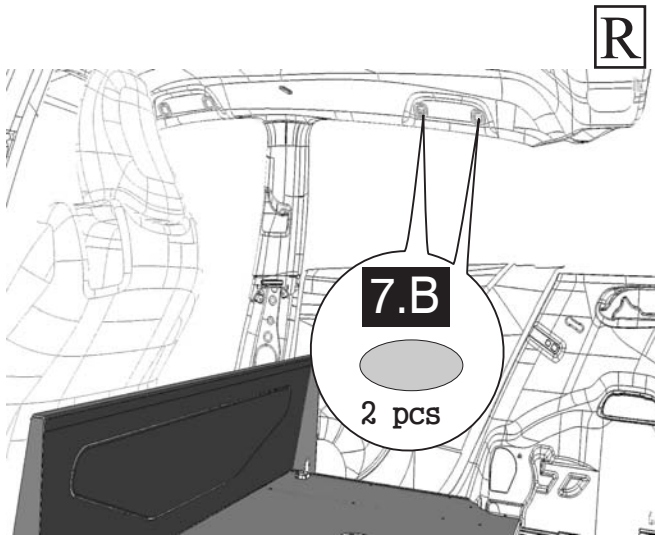

68.

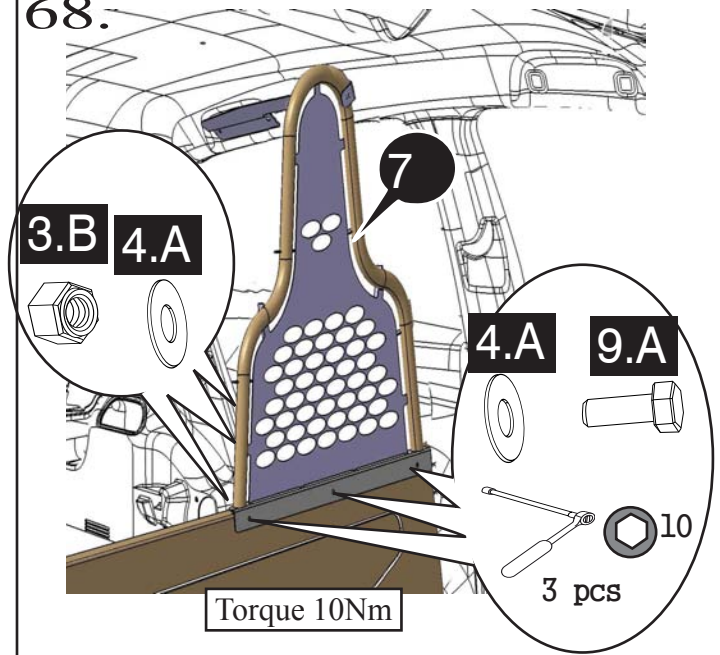

69.

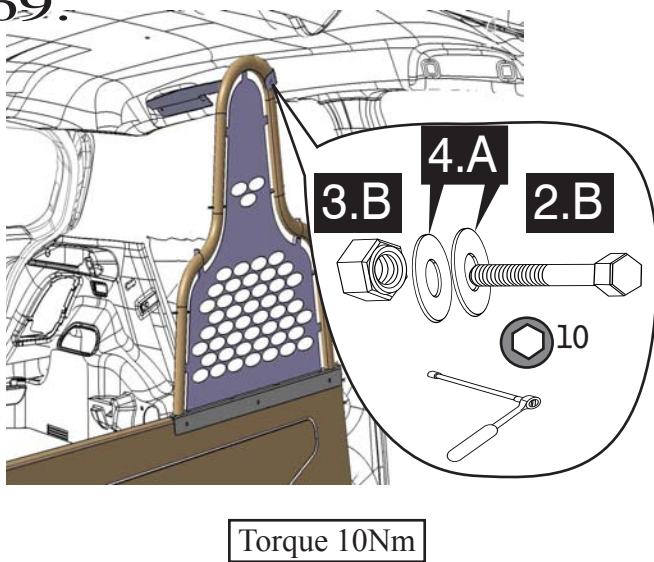

70.

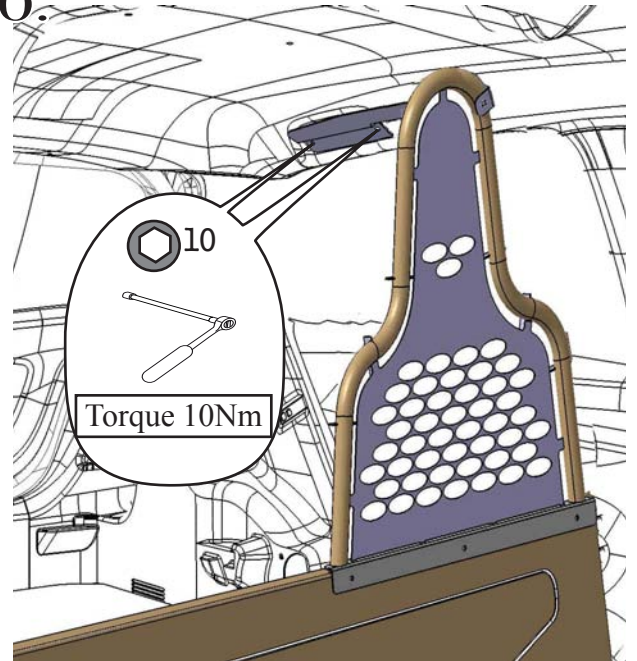

71.

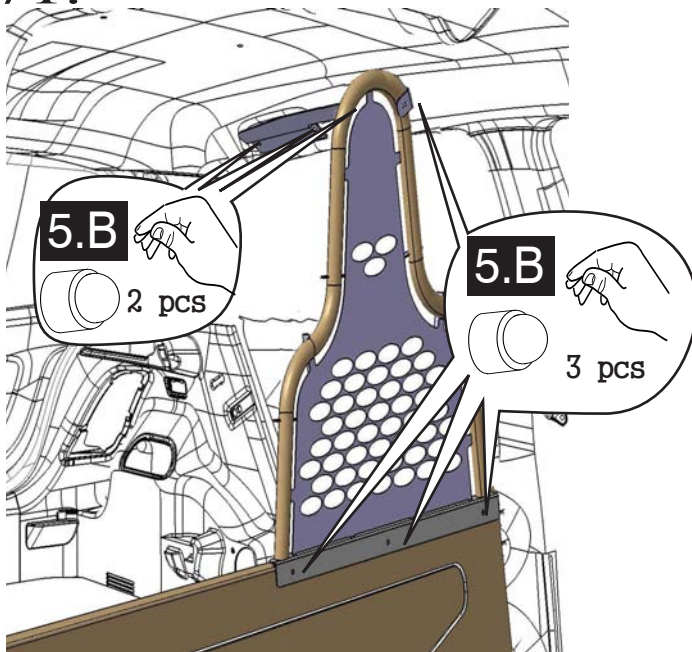

72.

L&R

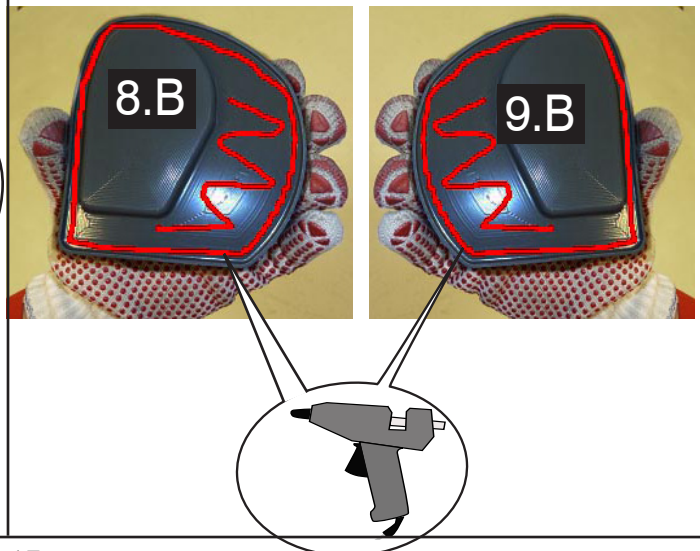

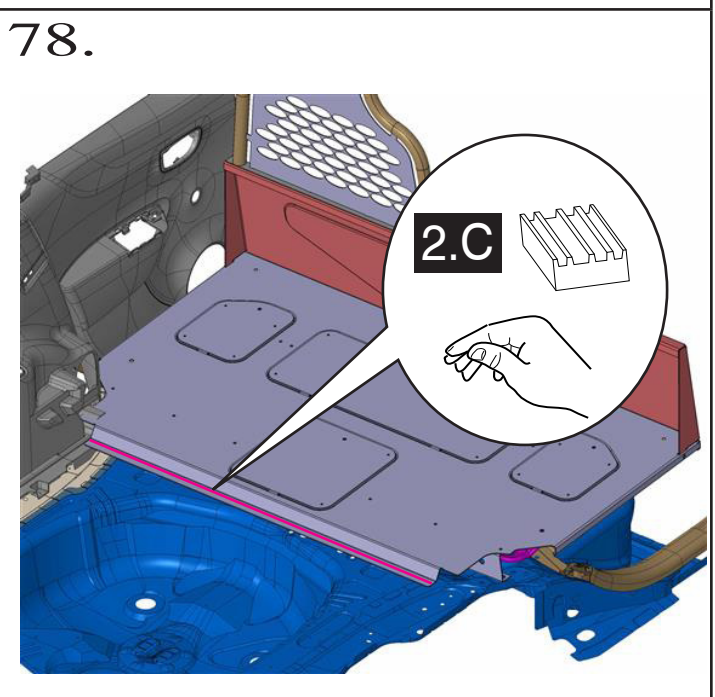
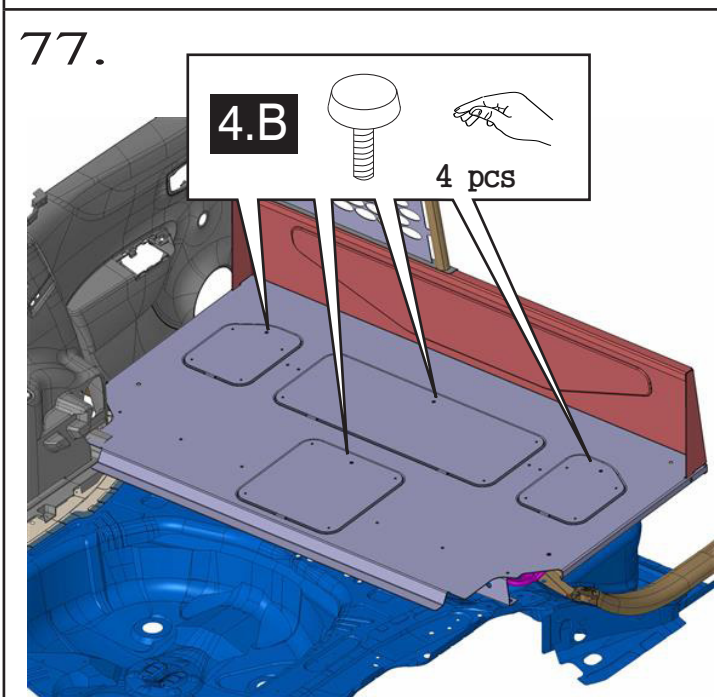
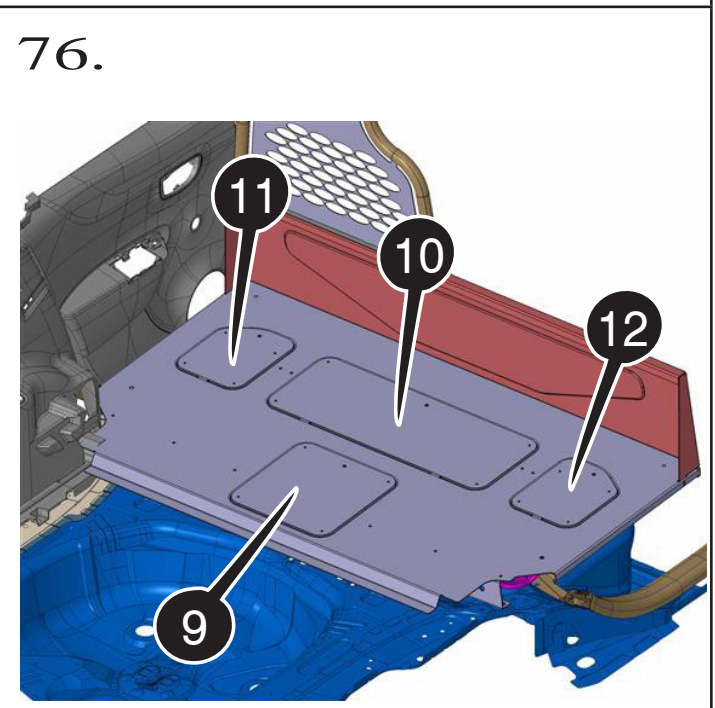
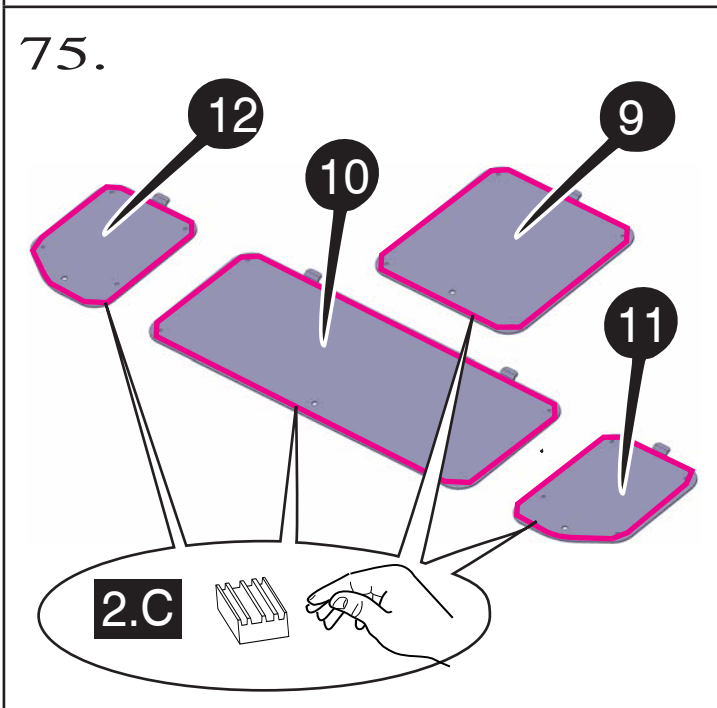

79.

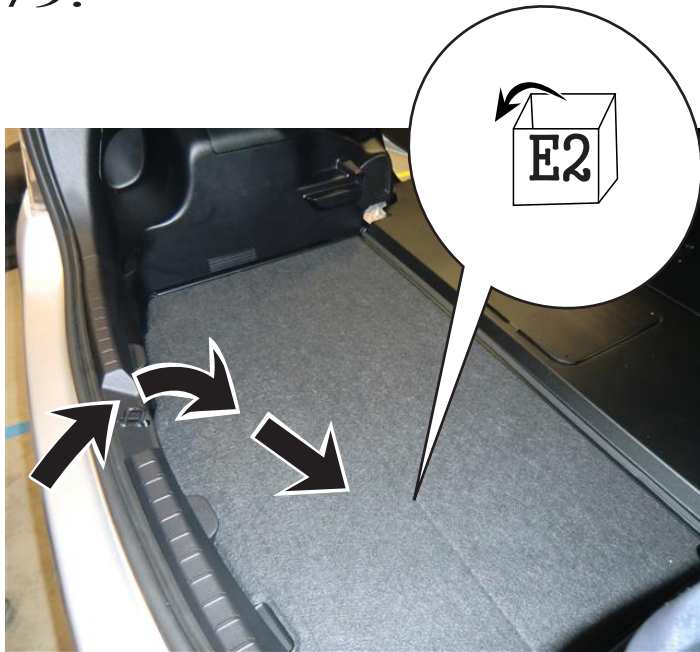

80.



81.

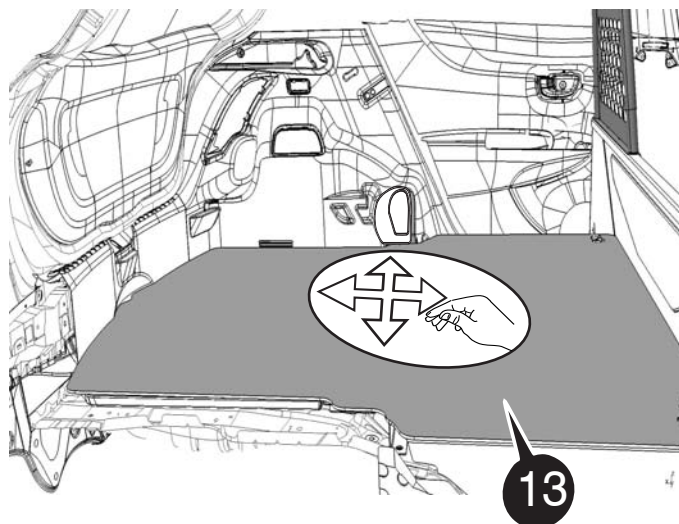

82.

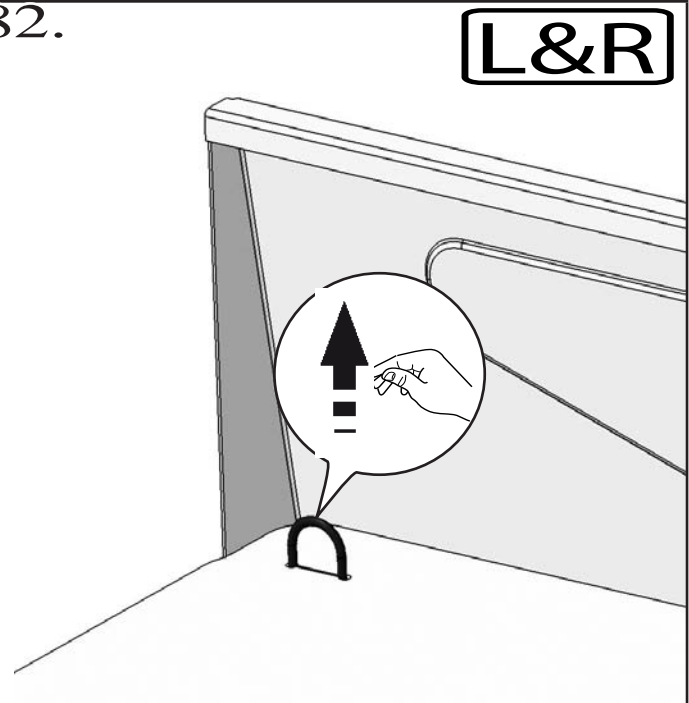

83.



REMOVE REAR DOOR WINDOW REGULATOR HANDLE ASSEMBLY (w/o Power Window)

- (a) Insert a clip remover between the plate and front door trim board.
- (b) Turn the handle with the clip remover inserted, as shown in the illustration.
- (c) Remove the front door window regulator handle and clip.
- (d) Remove the window regulator handle plate.

84.

L&R

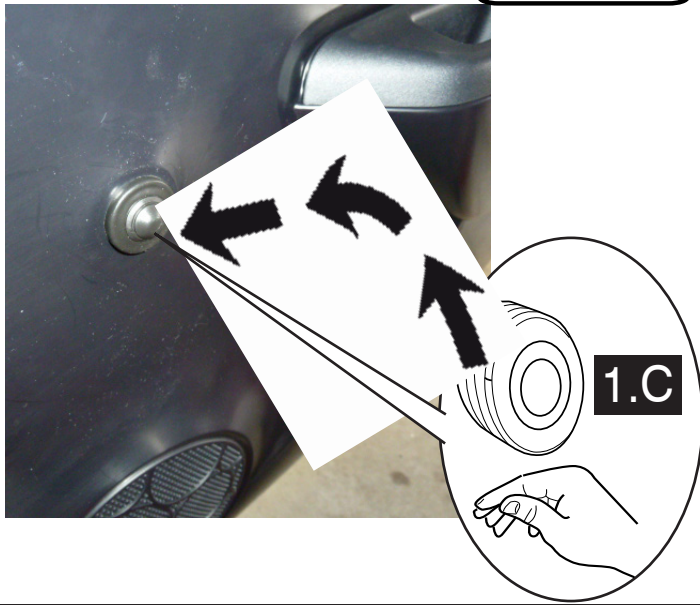

85.

L&R

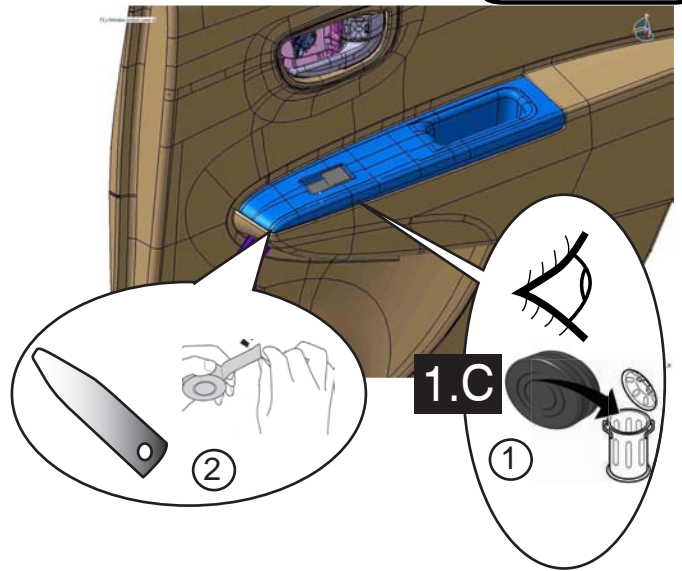

86.

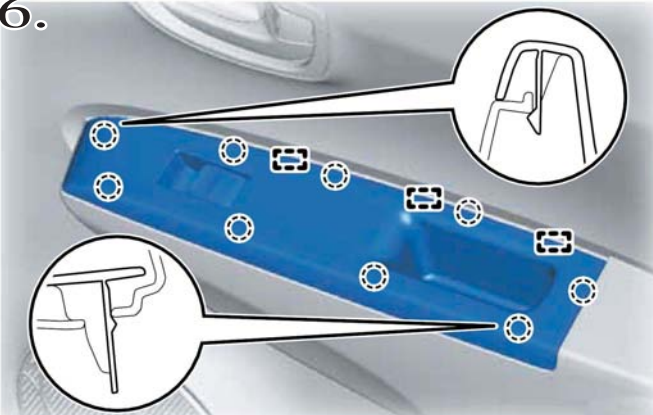

REMOVE REAR DOOR ARMREST BASE UPPER PANEL (w/ Power Window)

- (a) Using a moulding remover, disengage the 9 claws and 3 guides.
- (b) Disconnect the connector and remove the rear armrest base upper panel.

87.

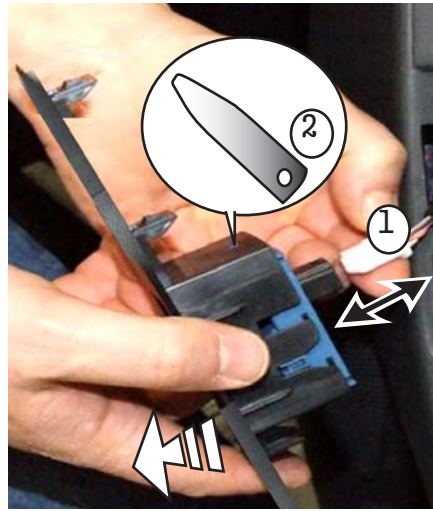

88.

L&R

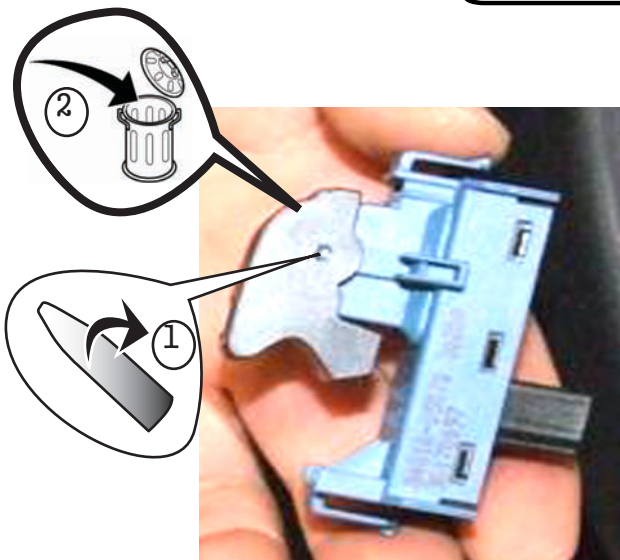

89.

L&R

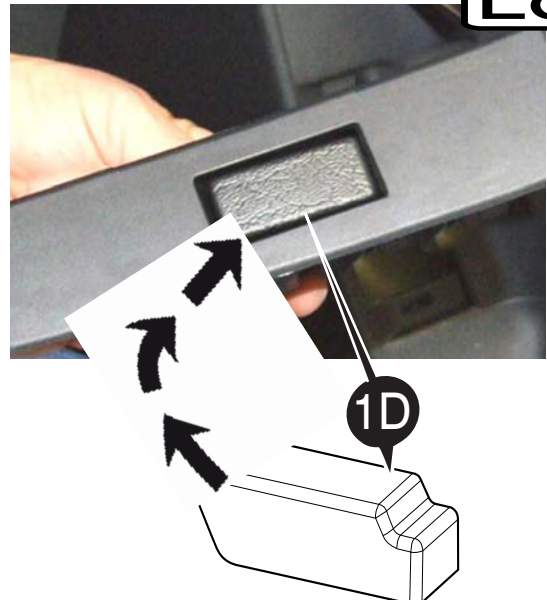

90.

L&R

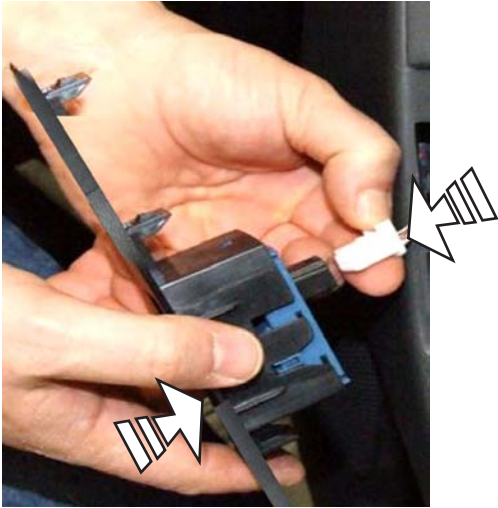

91.

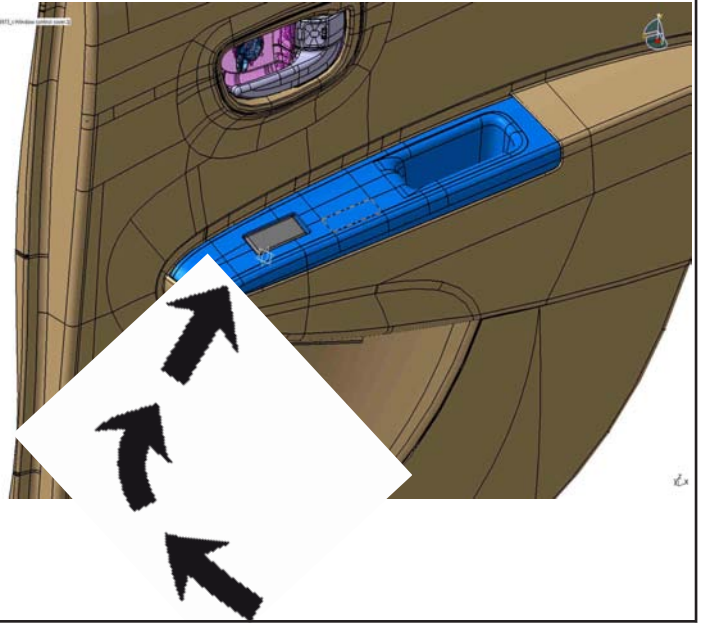

92.

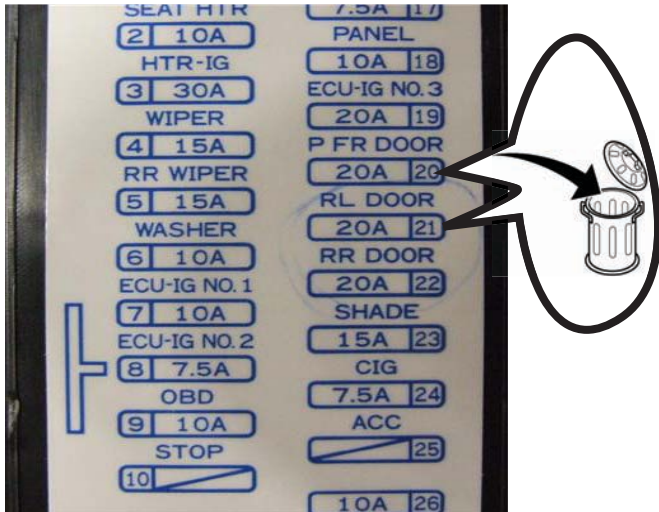

93.

L&R



94.

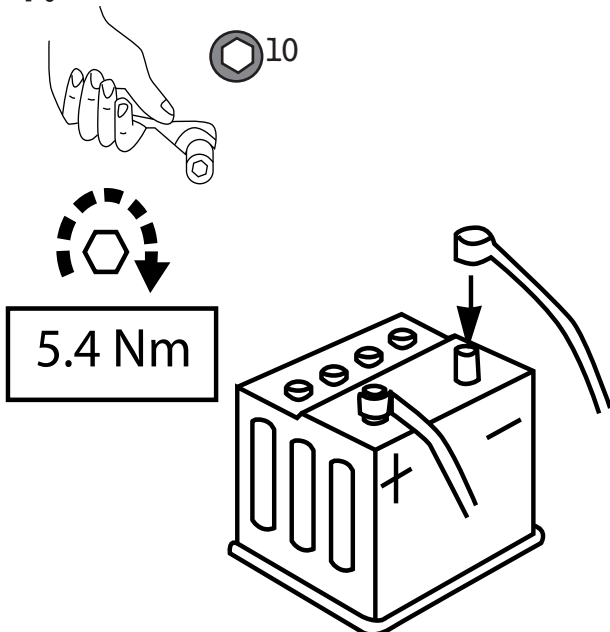

95.

CHECK SHEET



TOYOTA

Model / Year **Yaris Hybrid 2013**

N1 Kit TDK with steel separator

VIN n°

ALWAYS A BETTER WAY

P/N = OK

=A **=B**

S

42 Nm
4x

| A | B |
|----------------------|----------------------|
| <input type="text"/> | <input type="text"/> |

Serial Number

10 Nm
4x

| A | B |
|----------------------|----------------------|
| <input type="text"/> | <input type="text"/> |

Serial Number

S

1

10 Nm
4x

| A | B |
|----------------------|----------------------|
| <input type="text"/> | <input type="text"/> |

Serial Number

2

10 Nm
2x

| A | B |
|----------------------|----------------------|
| <input type="text"/> | <input type="text"/> |

Serial Number

S

1

10 Nm
2x

| A | B |
|----------------------|----------------------|
| <input type="text"/> | <input type="text"/> |

Serial Number

2

10 Nm
4x

| A | B |
|----------------------|----------------------|
| <input type="text"/> | <input type="text"/> |

Serial Number

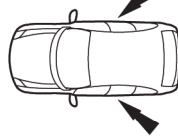

| |
|----------------------|
| <input type="text"/> |
| <input type="text"/> |

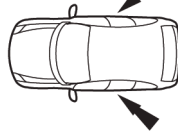

| |
|----------------------|
| <input type="text"/> |
| <input type="text"/> |

= OK

Installation Date:

... / ... / ...

Technician Name & Signature:

Stamp:

