

Front Bumper Garnish INSTALLATION INSTRUCTIONS NX

Model year	As from 2021/09
Vehicle code	*AZ*2**-AW*LBW
Part number	PW401-78010-** PW401-78020-**

**Latest Version
SCAN HERE**



CLICK TO NAVIGATE

REVISION RECORD



Page

3

KIT CONTENT



Page

4

LEGEND



Page

4

USEFUL GENERAL MANUALS



Page

4

TOOLS



Page

5

CONSUMABLES



Page

5

PERSONAL PROTECTION EQUIPMENT



Page

5

GENERAL



Page

6

INSTALLATION INSTRUCTIONS



Pages

7 - 22

GENERAL



Page

22

CHECK SHEET



Pages

23 - 25



Revision Record

Rev. No.	Date	Page	Step	Remarks
1	22.11.2023	1	Kit	Part Number "PW401-78020-***" added
1	22.11.2023	12	9-10	Temp. checks updated to latest standards
1	22.11.2023			Updated to latest Standards

KIT CONTENT

PW401-78010-**
PW401-78020-**



A

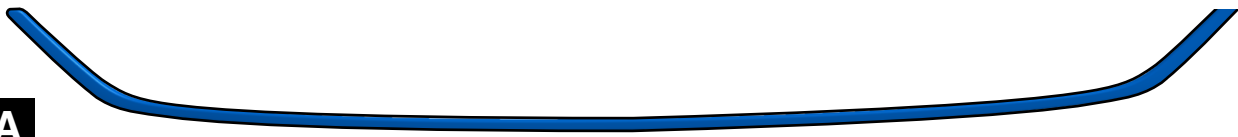

x1

B

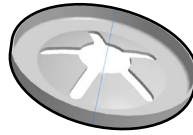

x3

C

Template

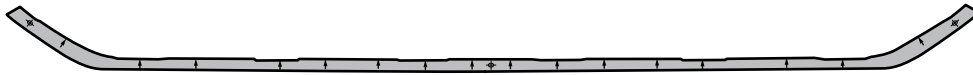





x1

LEGEND

= XX mm	= or	=
= XX mm	=	=
= XXX	=	=
= TXX	=	= START

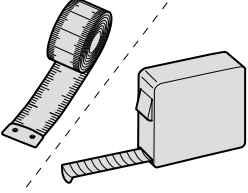
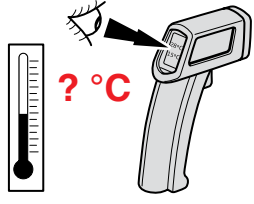
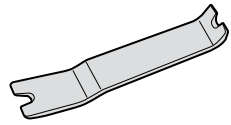
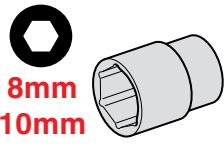
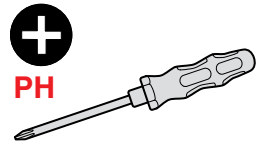
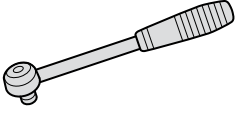
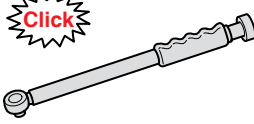
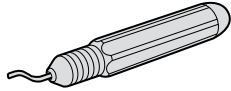
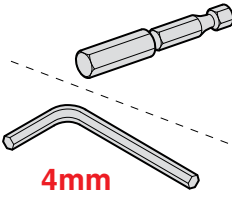
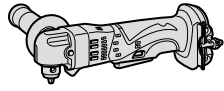
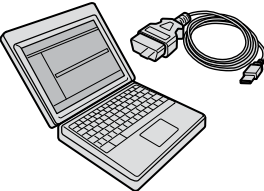
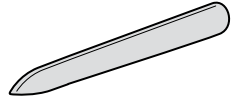
USEFUL GENERAL MANUALS

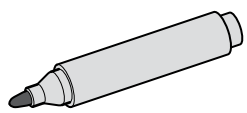
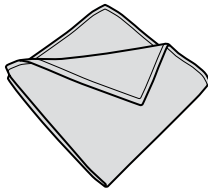
<p>SYMBOLS</p> <p>Latest Version SCAN HERE</p>	<p>CLEANER / DEGREASER</p> <p>Latest Version SCAN HERE</p>	
<p>INSTALLATION CONDITIONS</p> <p>Latest Version SCAN HERE</p>	<p>DISCLAIMER</p> <p>Latest Version SCAN HERE</p>	

TOOLS				
TAPE MEASURE	TEMPERATURE SENSOR	PLASTIC TRIM REMOVAL TOOL	HEXAGONAL SOCKET	PHILIPS SCREW DRIVER
			 8mm 10mm	 +
RATCHET	TORQUE WRENCH	DE-BURRING TOOL	HEX KEY	
			 4mm	 Ø 3,5 mm Ø 6 mm Ø 9 mm
LEXUS GTS DIAGNOSTIC TOOL	PLASTIC TRIM REMOVAL TOOL			
				
CONSUMABLES				
MASKING TAPE	CLEANER / DEGREASER	NON PERMANENT MARKER	MICROFIBRE CLOTH	
 MASKING TAPE	 CLEANER DEGREASER			 09053-1C200
PERSONAL PROTECTION EQUIPMENT				
SAFETY GLASSES				
				

GENERAL

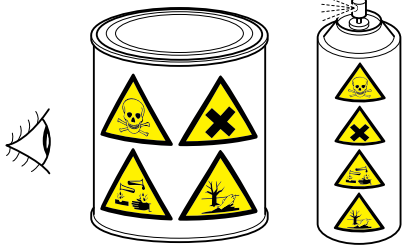

Material Safety Data Sheet



Technical Data Sheet

GENERAL



20°C - 40°C

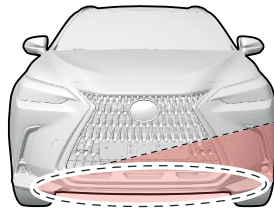

20°C - 40°C



40°C
20°C

20°C - 40°C

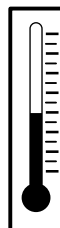
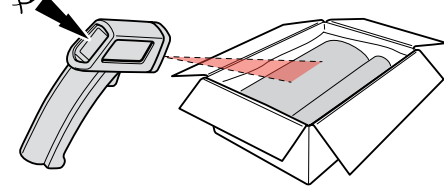

40°C
20°C



GENERAL



1

PUSH

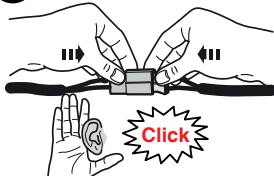

2

PULL



3

PUSH

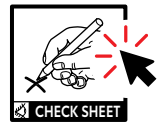
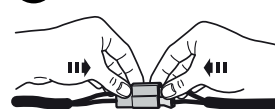

INSTALLATION INSTRUCTIONS

CONVENTIONAL

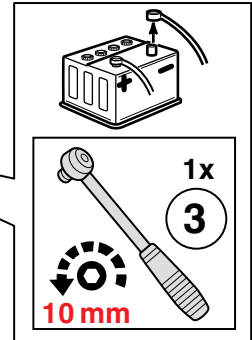
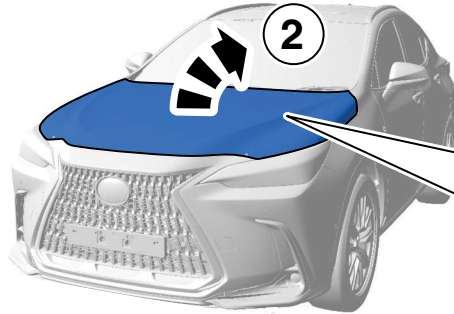

HYBRID

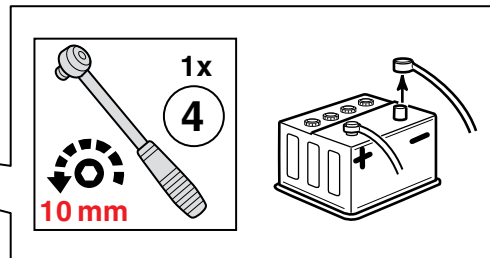
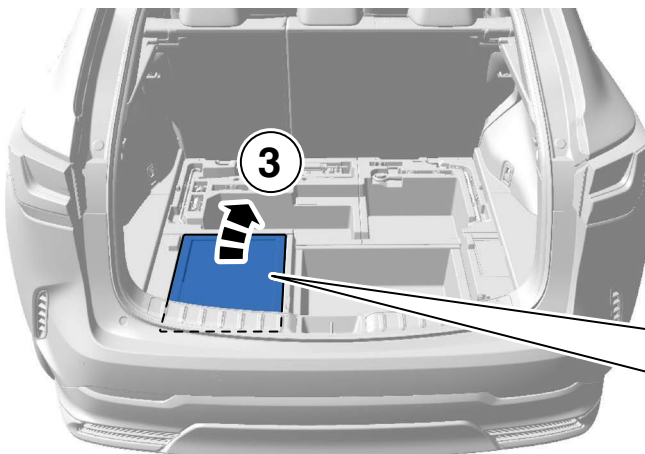
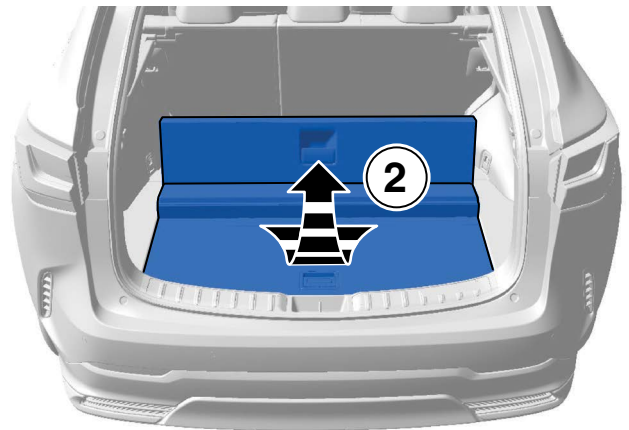

1

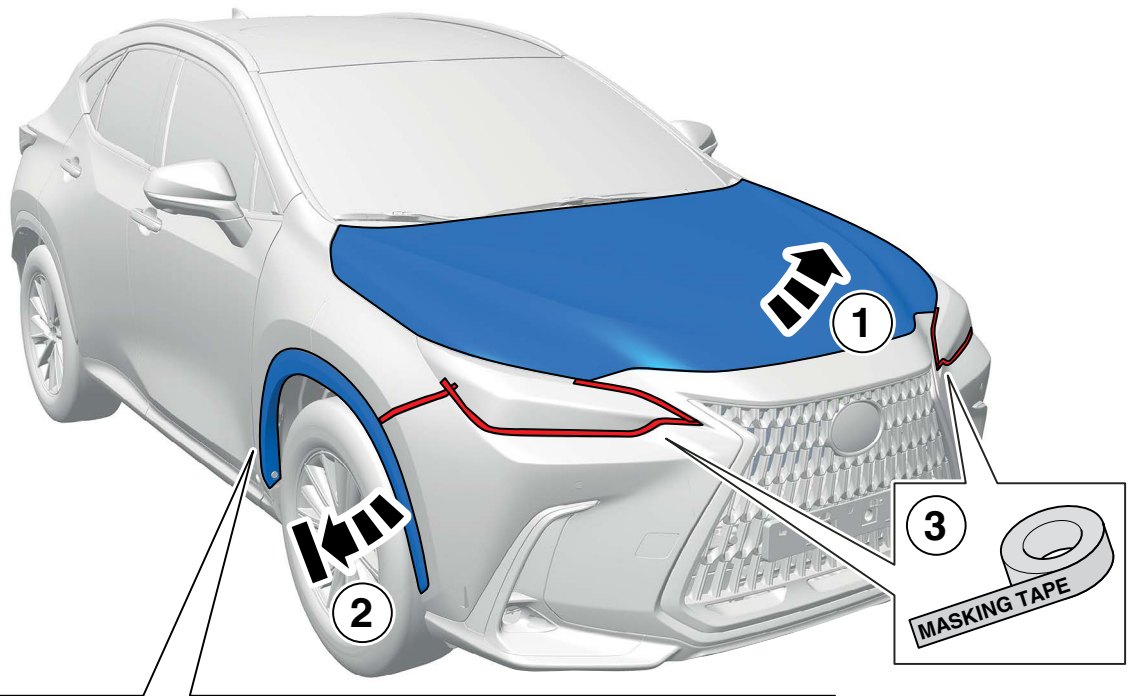

LHS=RHS

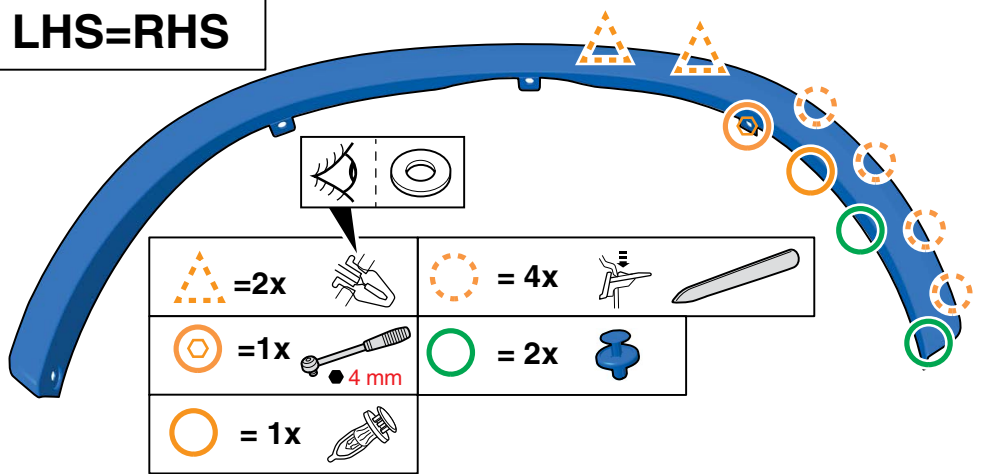

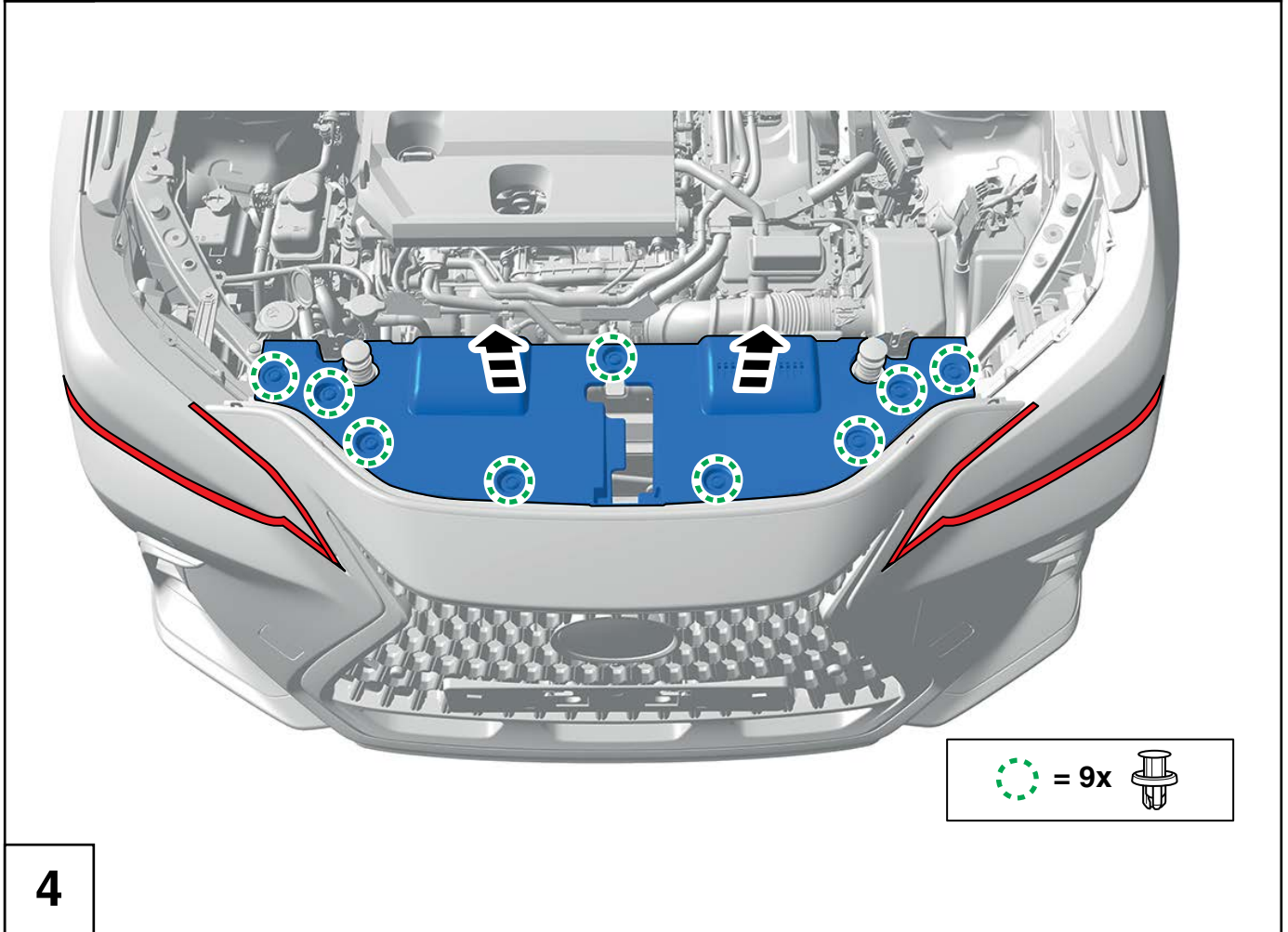
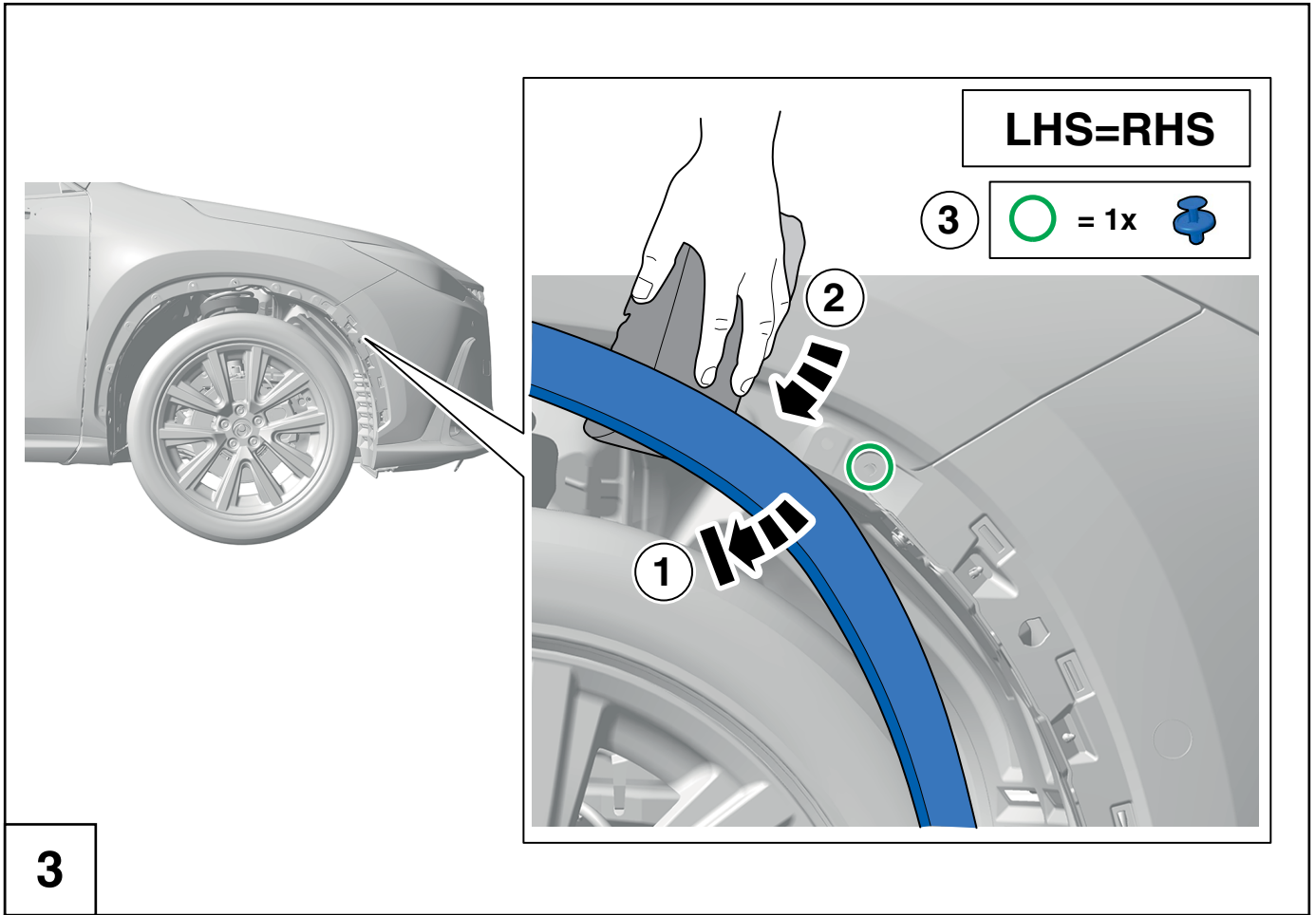

2



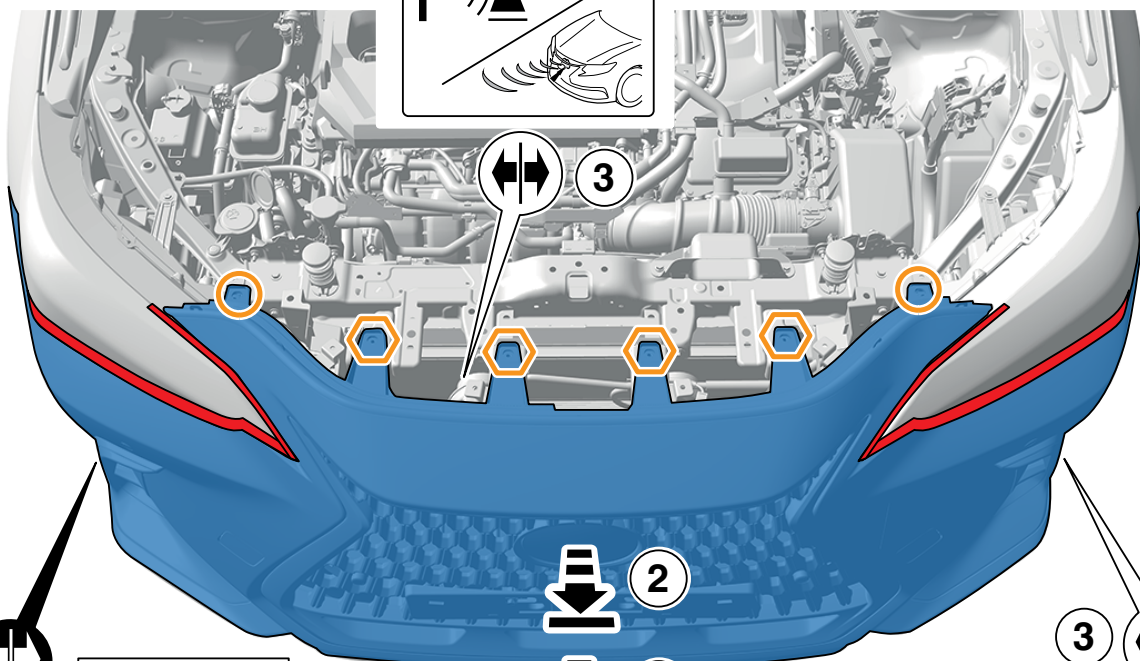
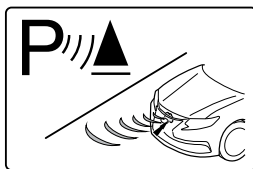
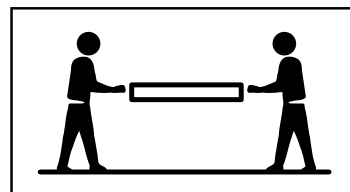

1 ○ = 2x 

1 ○ = 4x 10 mm 



3  = 1x 



2x  

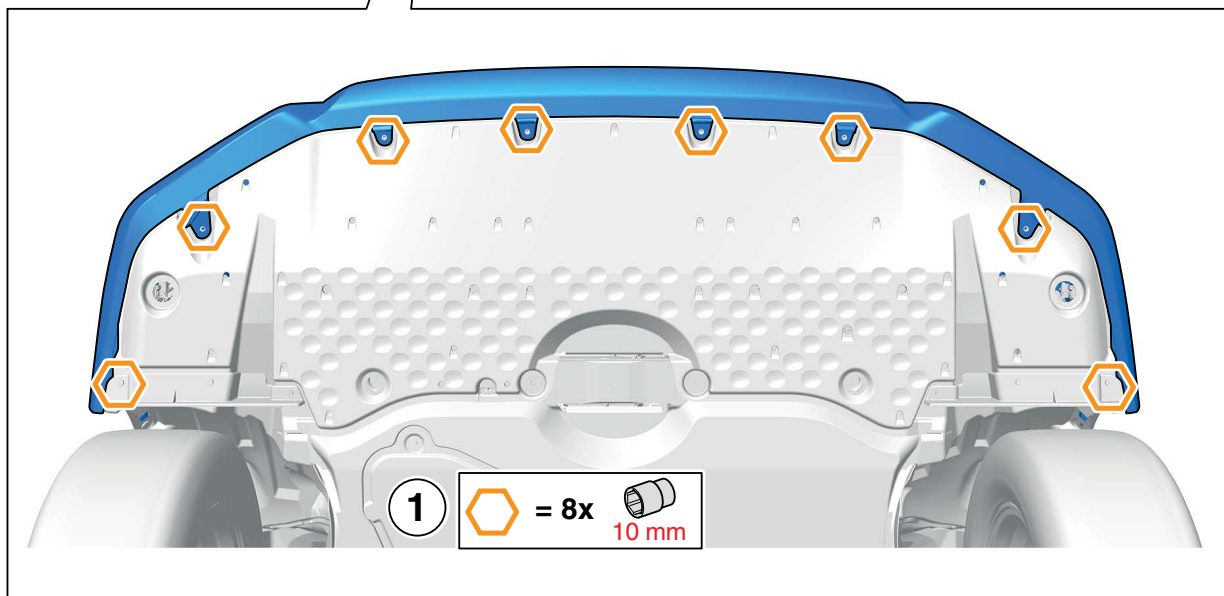

1 ○ = 8x 10 mm 

5

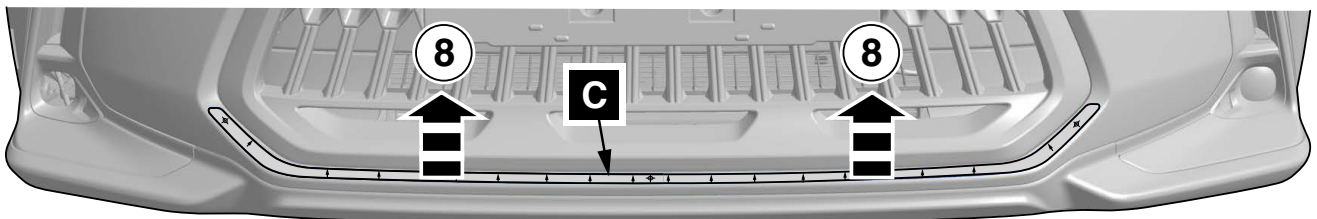
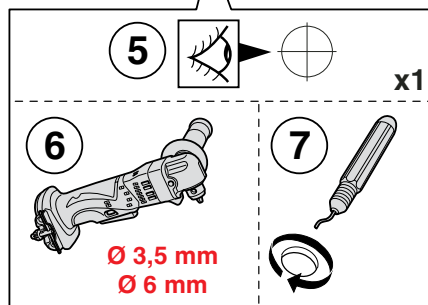
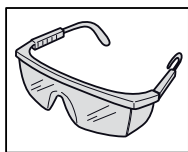
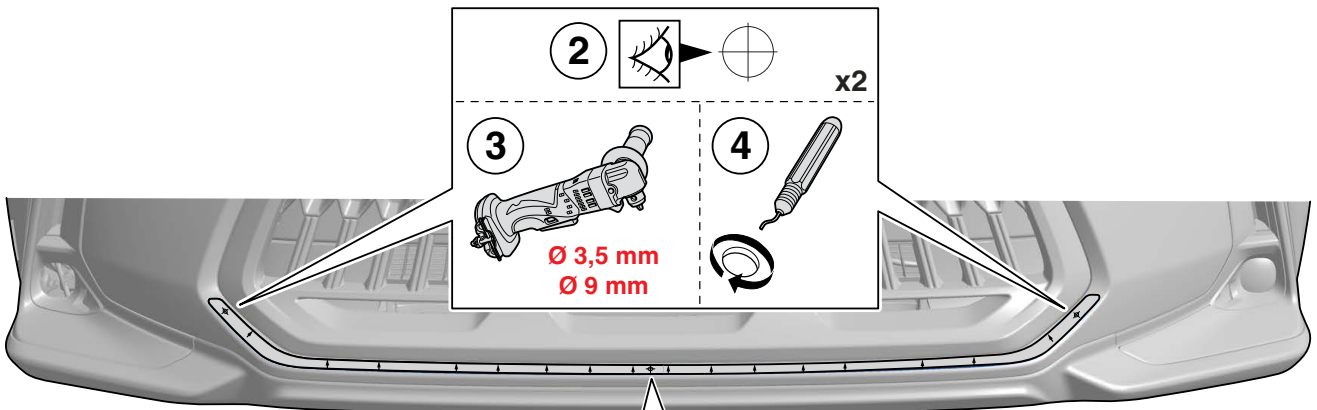
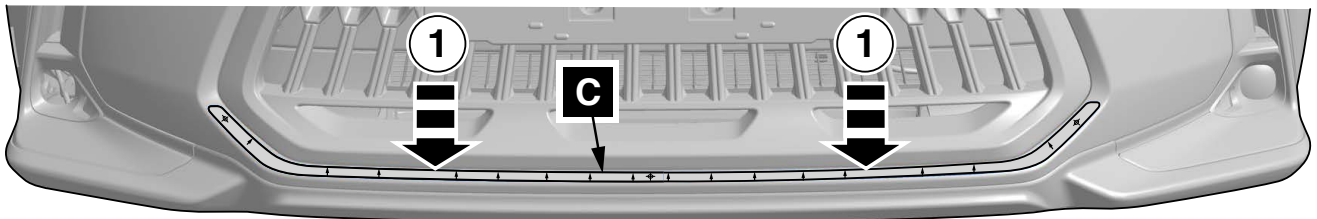
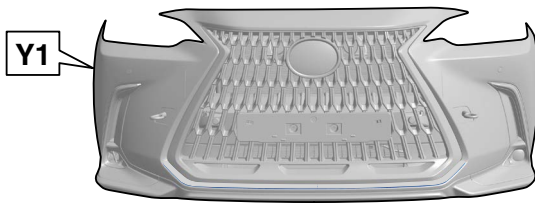

6

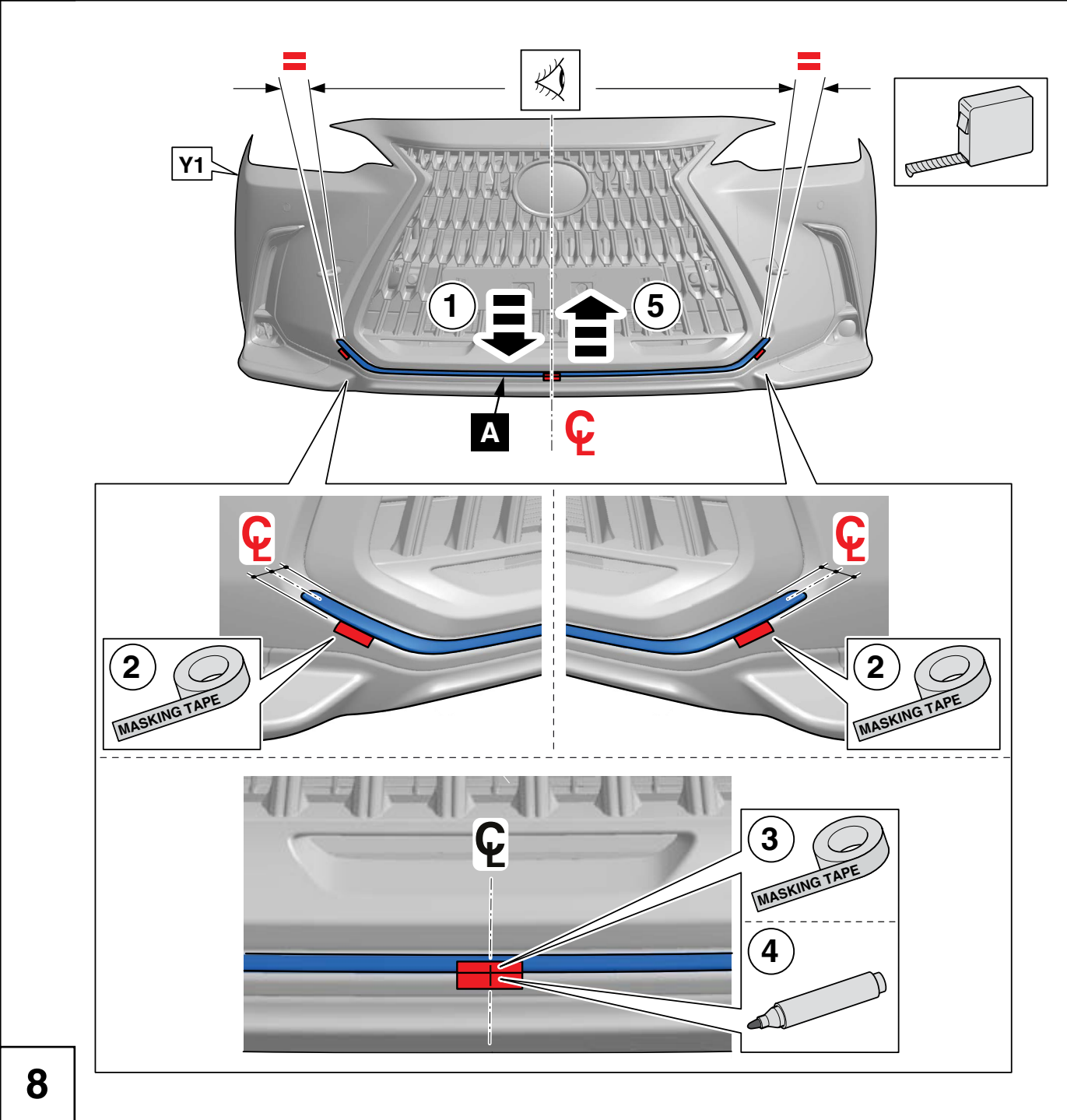
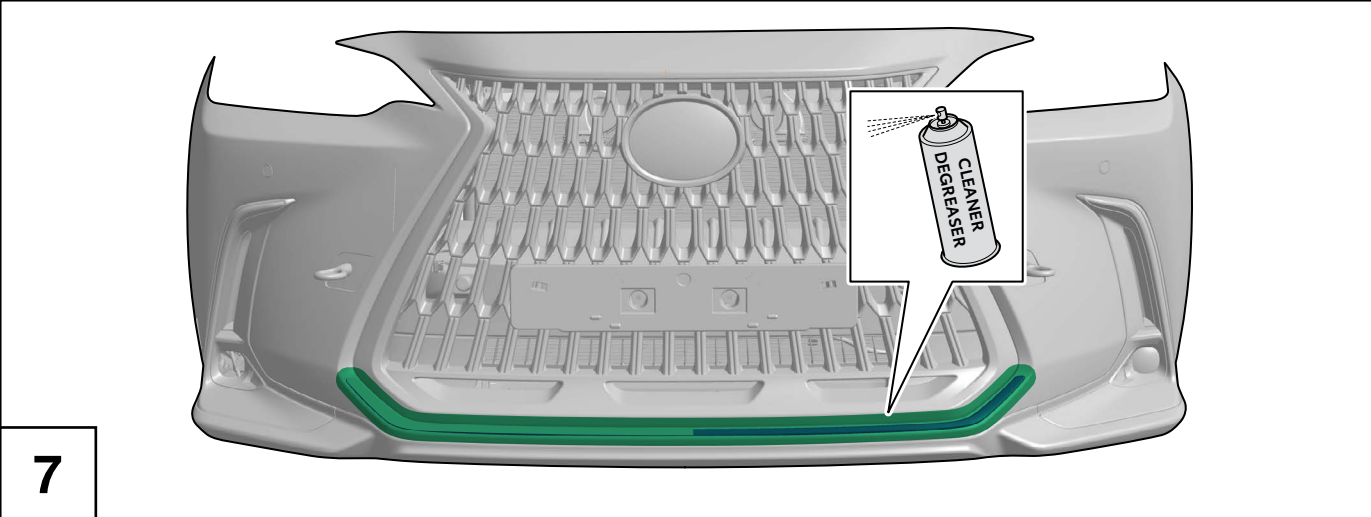

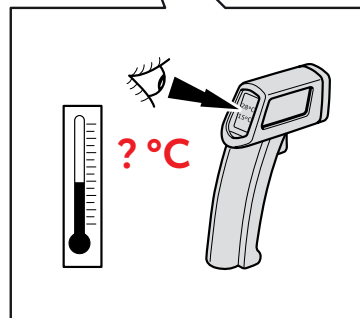
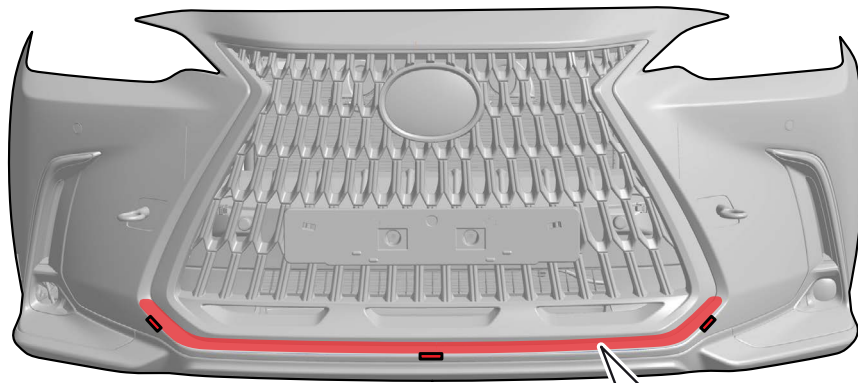

9

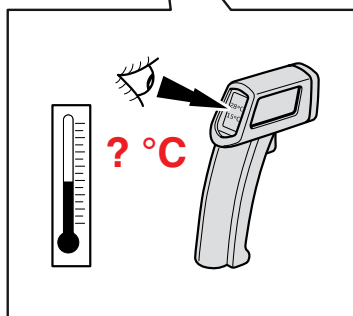

10

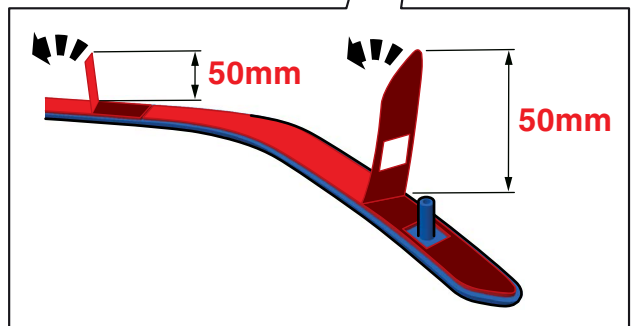
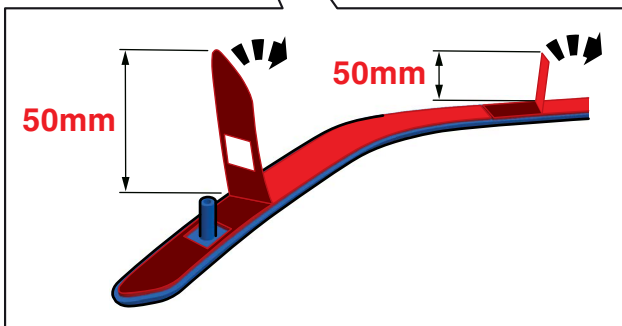
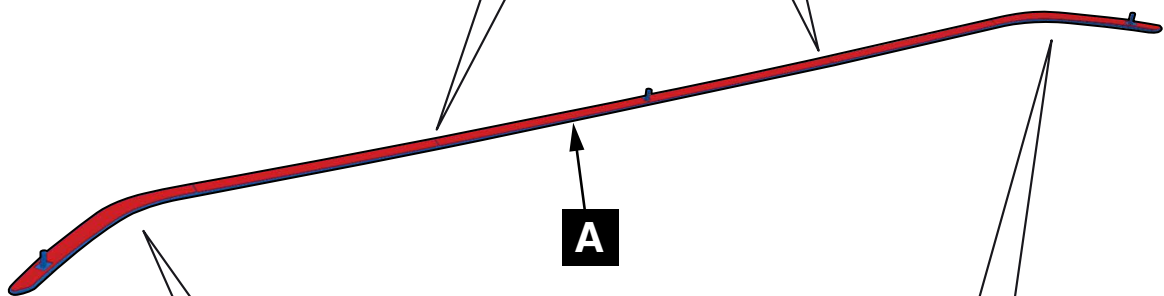
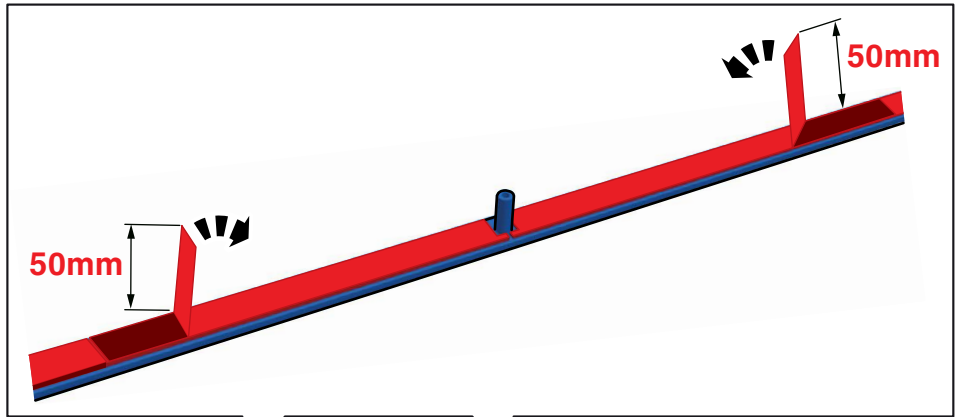
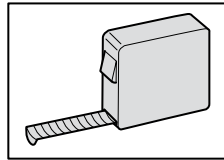
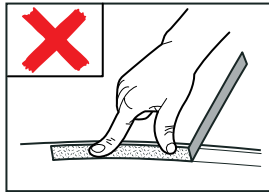

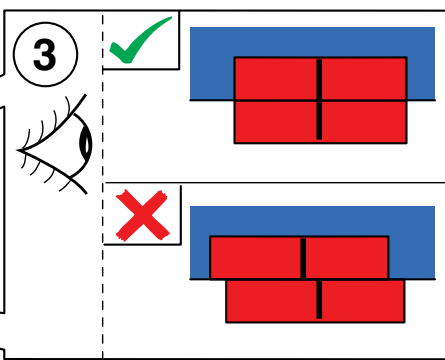
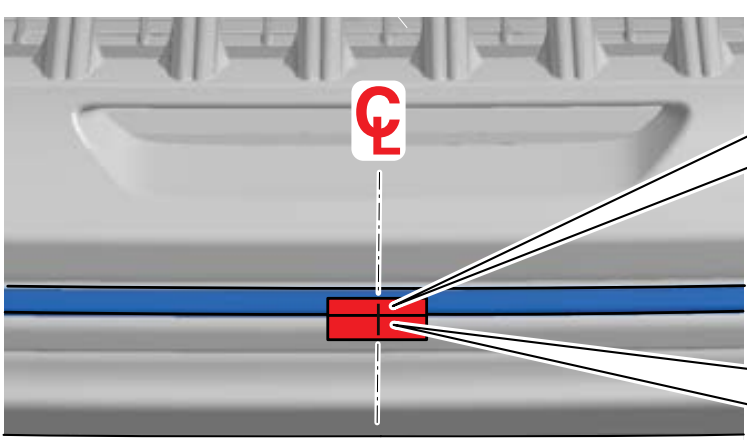
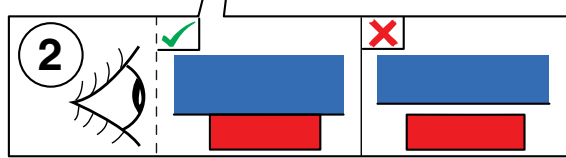
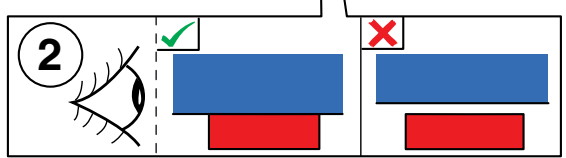
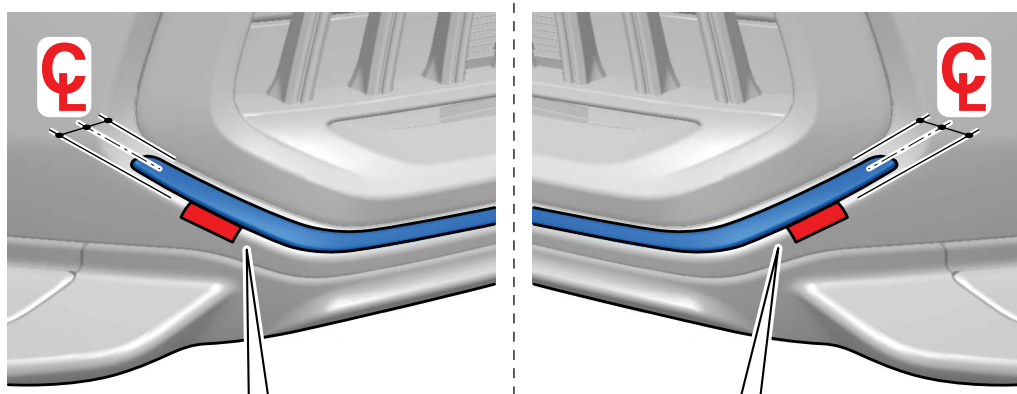
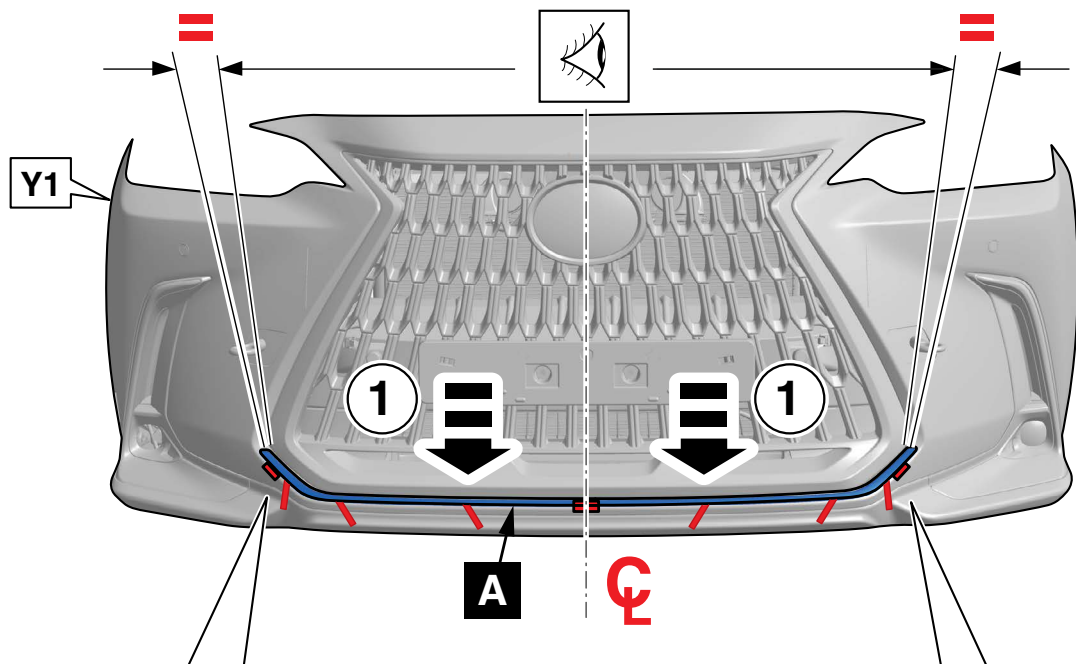

12

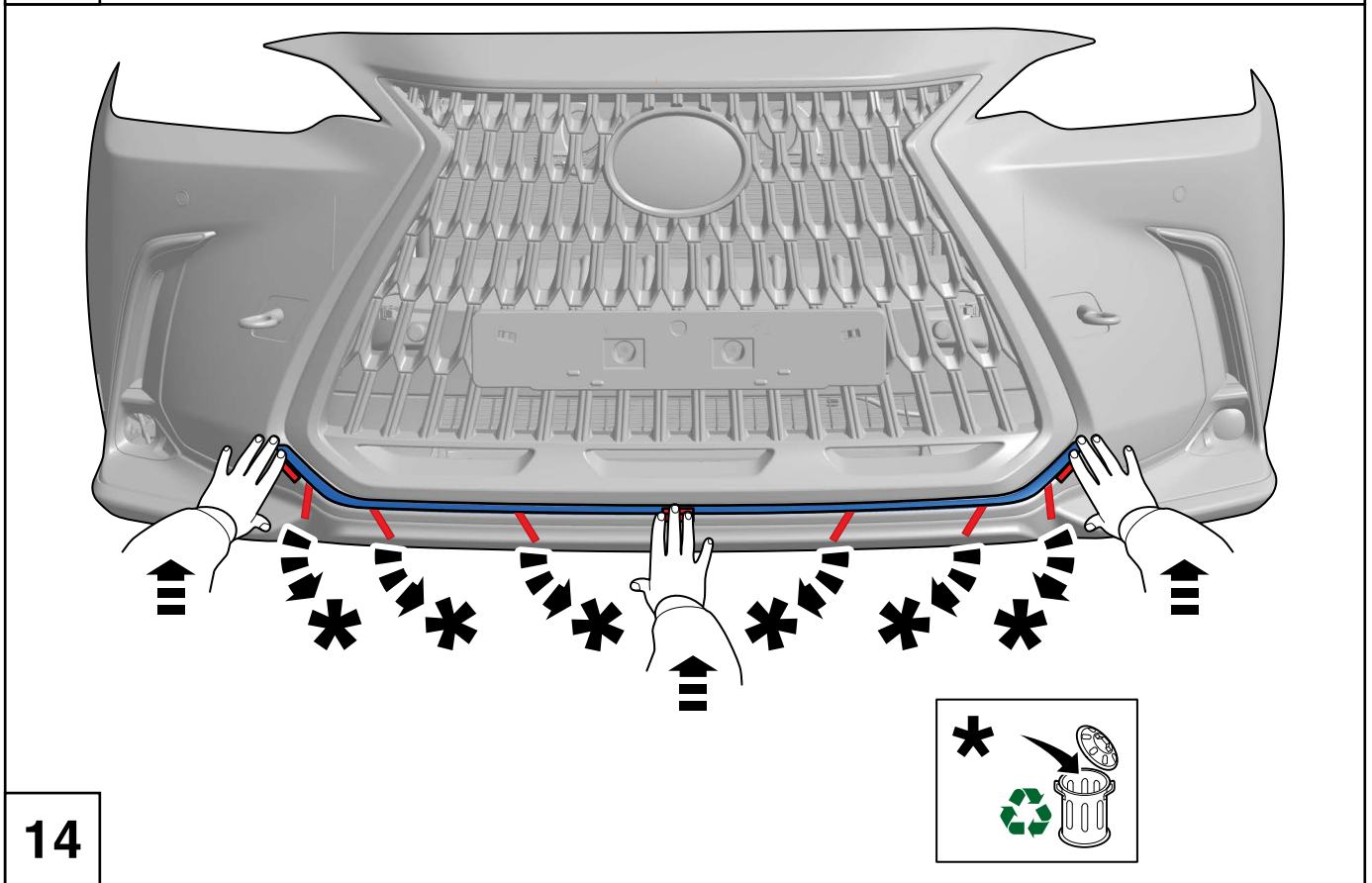
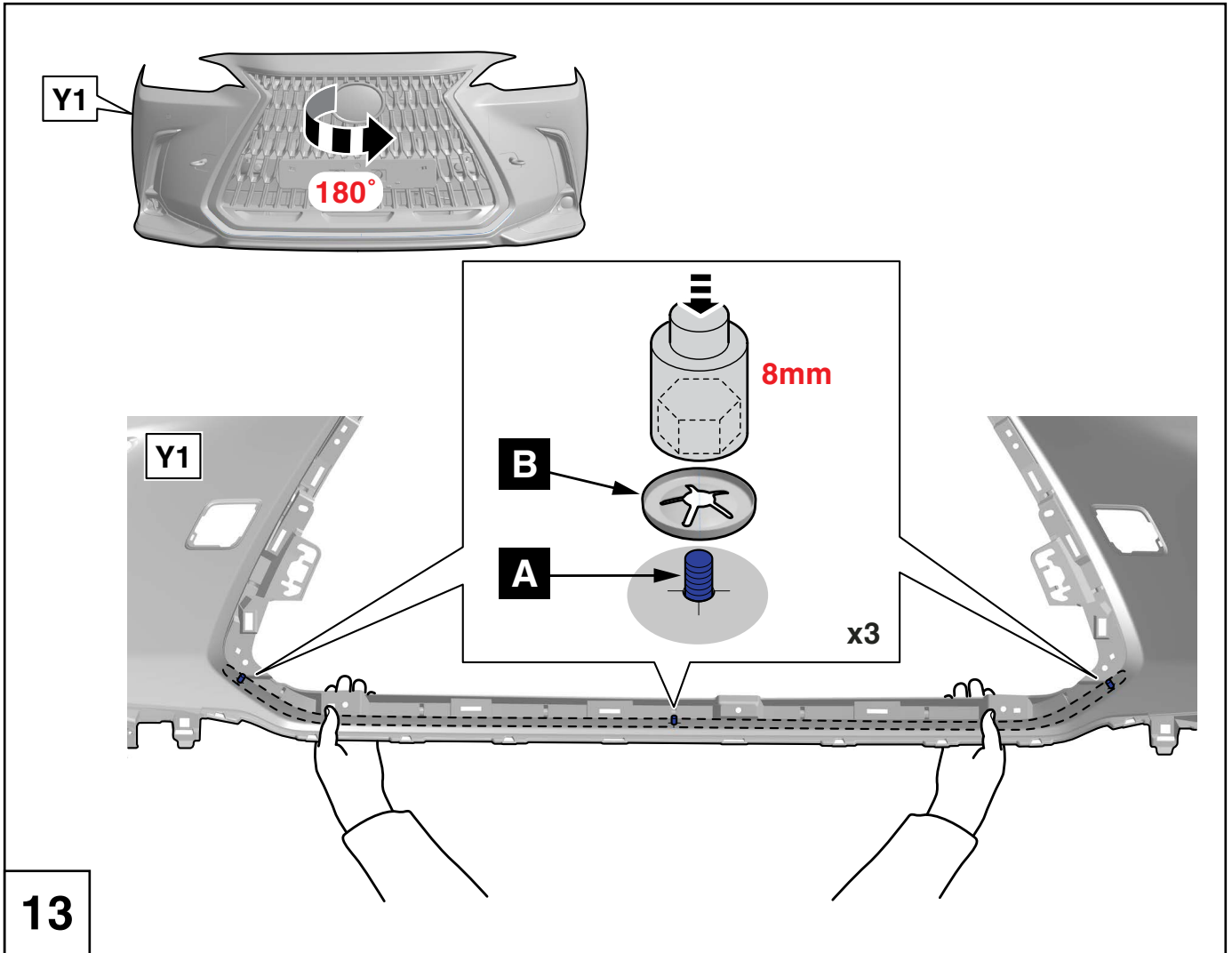

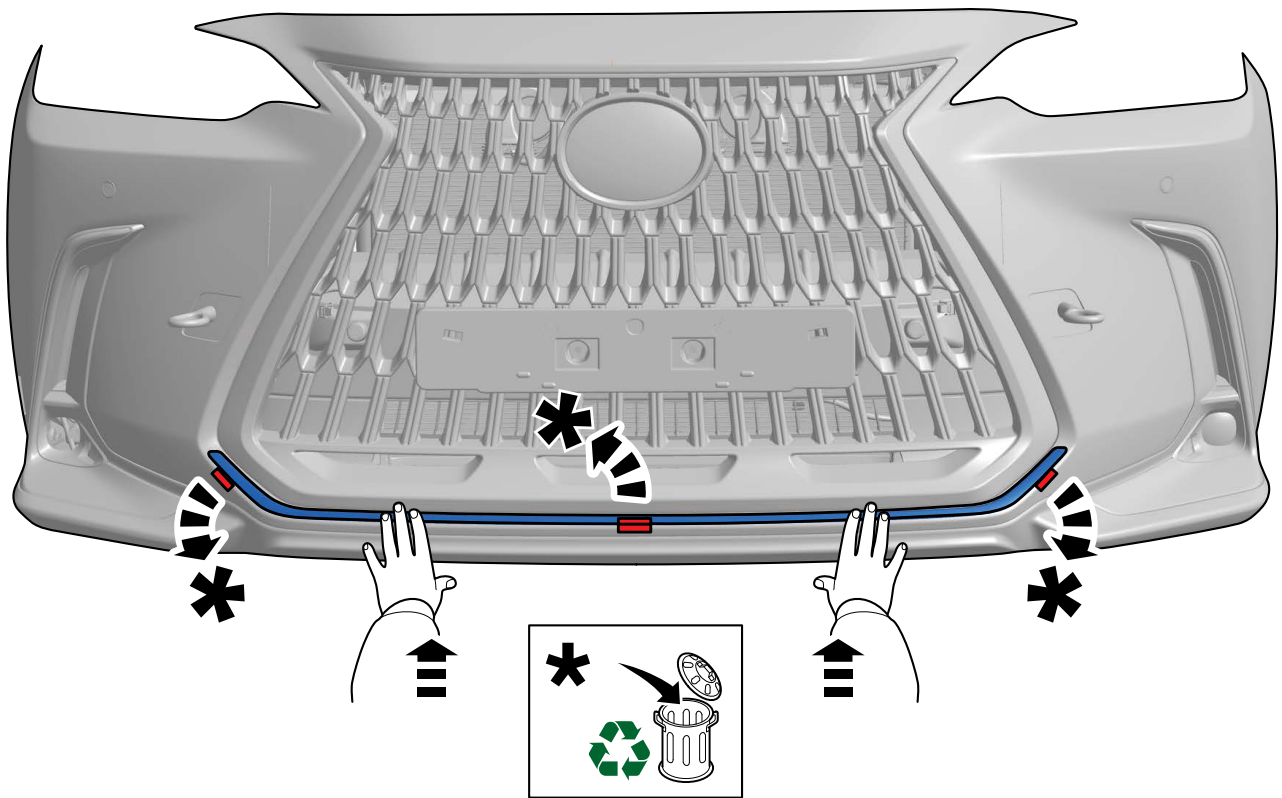

15

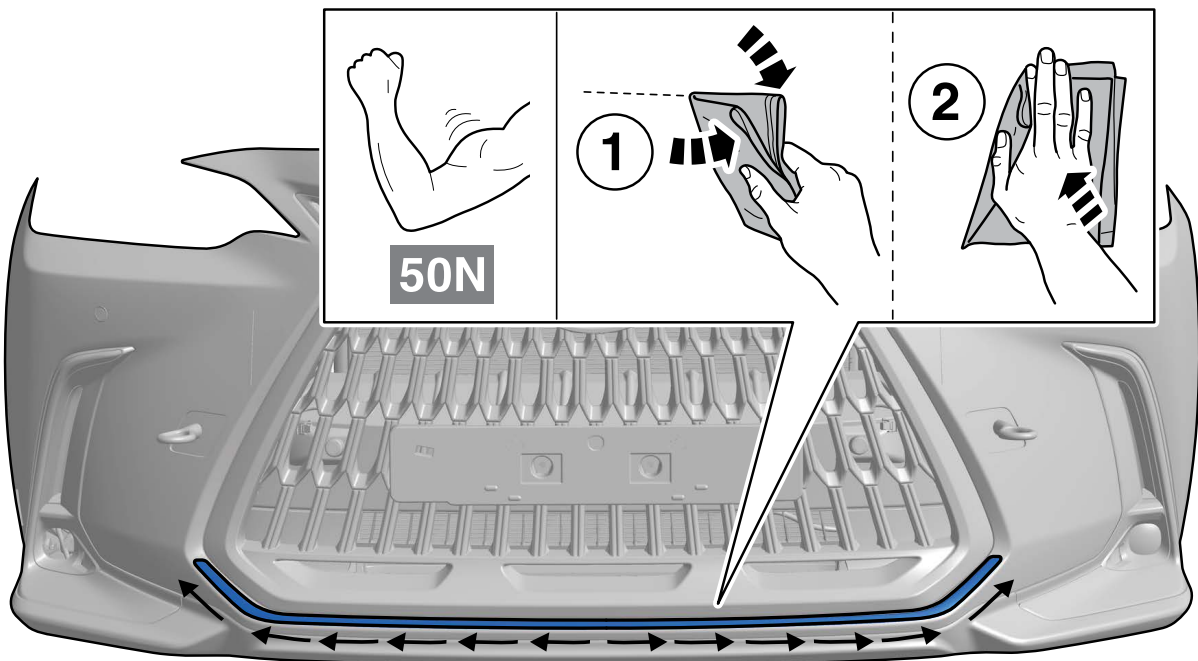

16

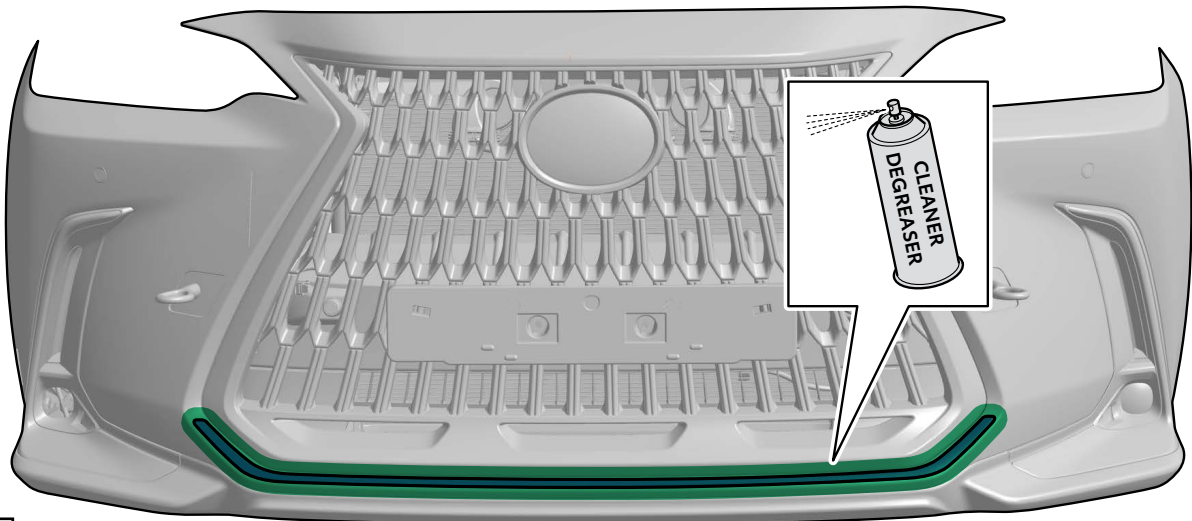

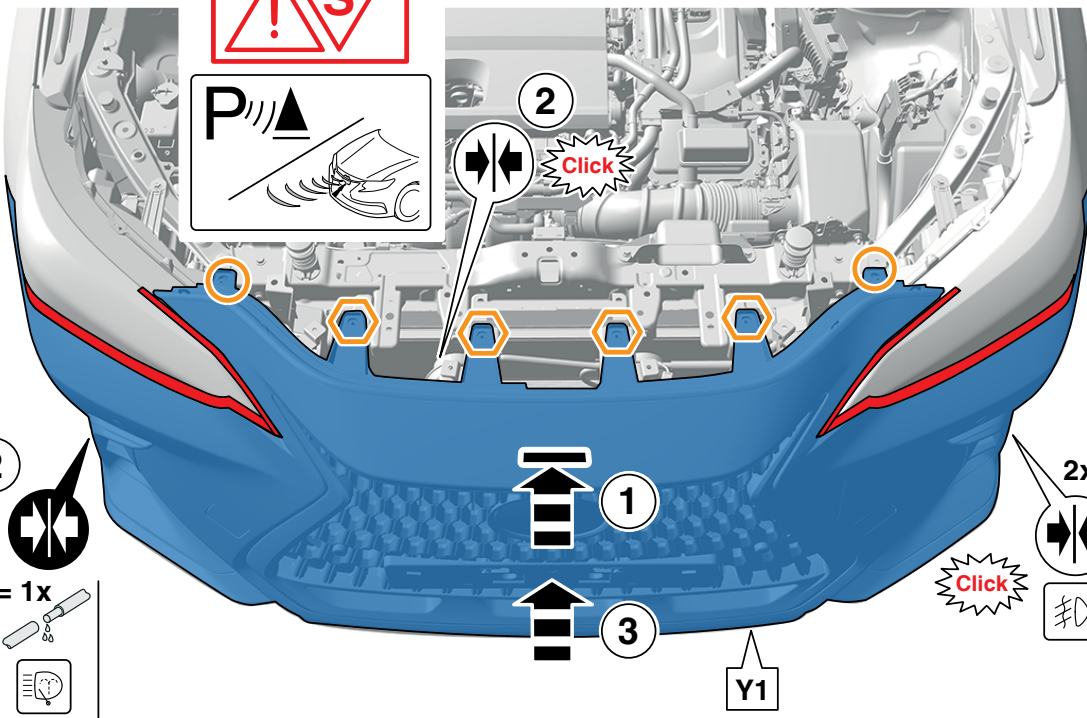
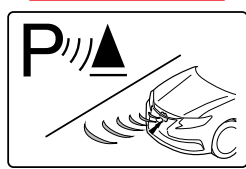
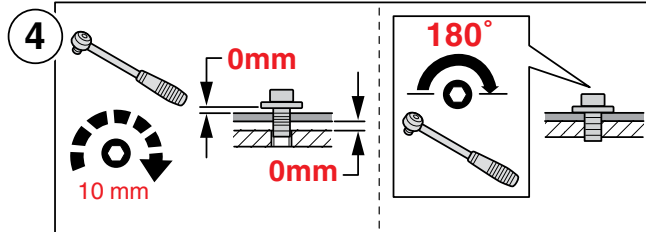
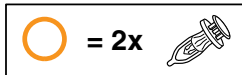
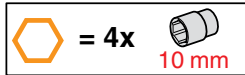
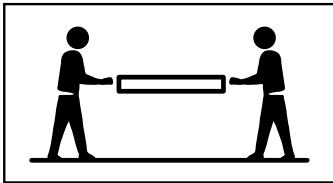

17



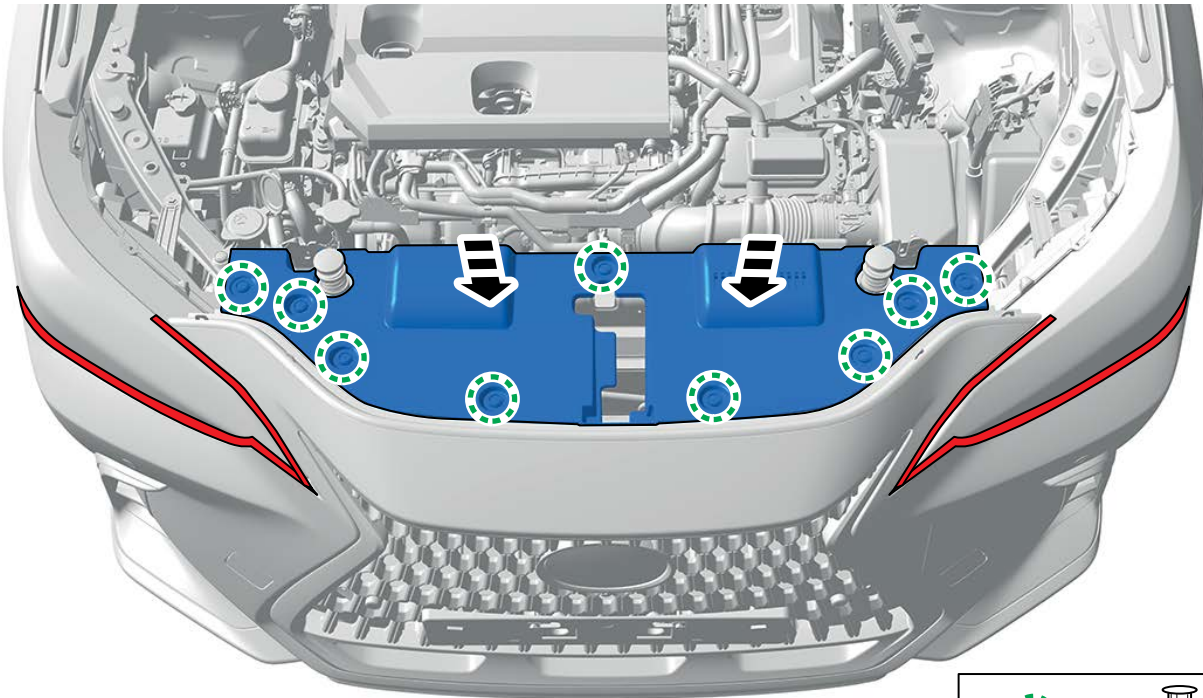

18

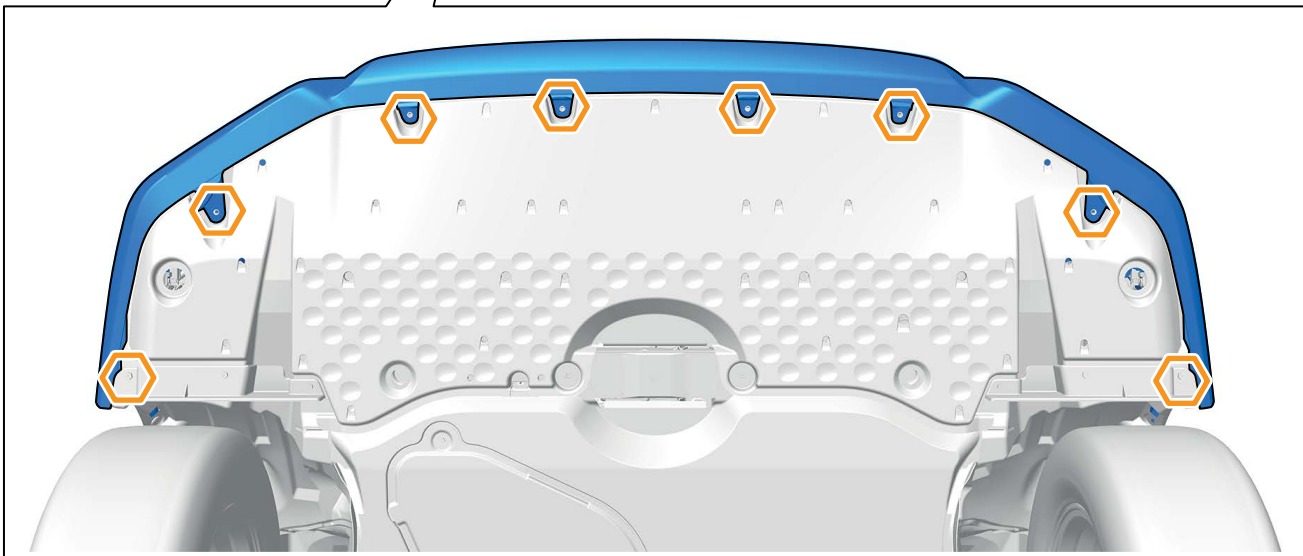

 = 9x 



 = 8x  10 mm

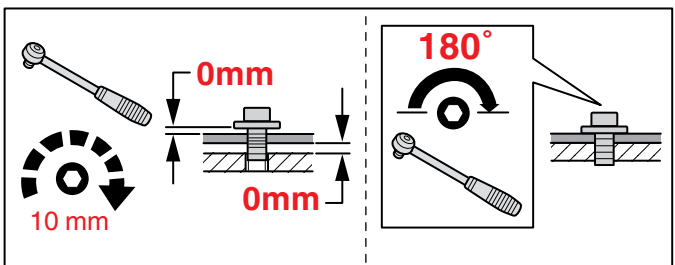

19

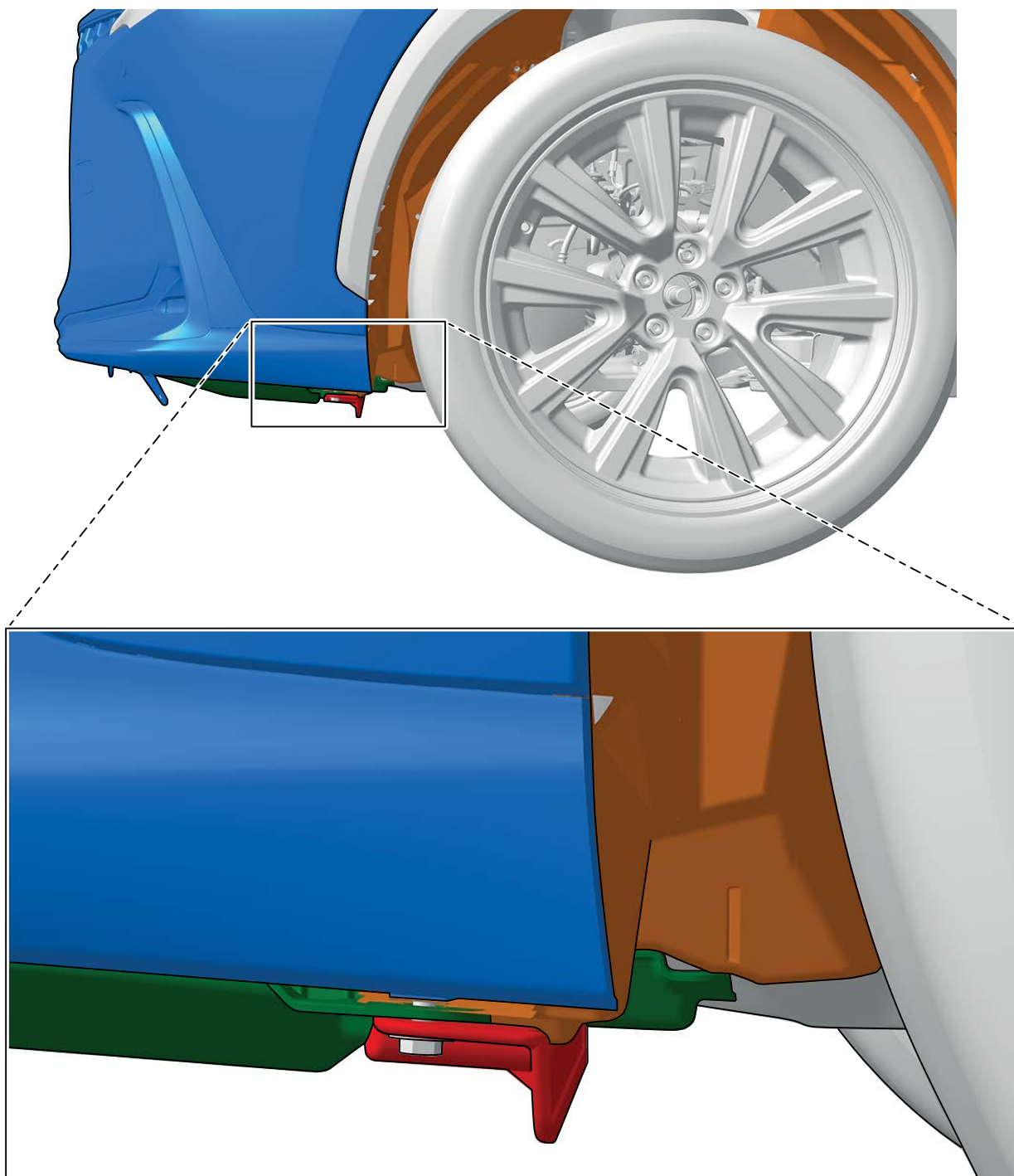

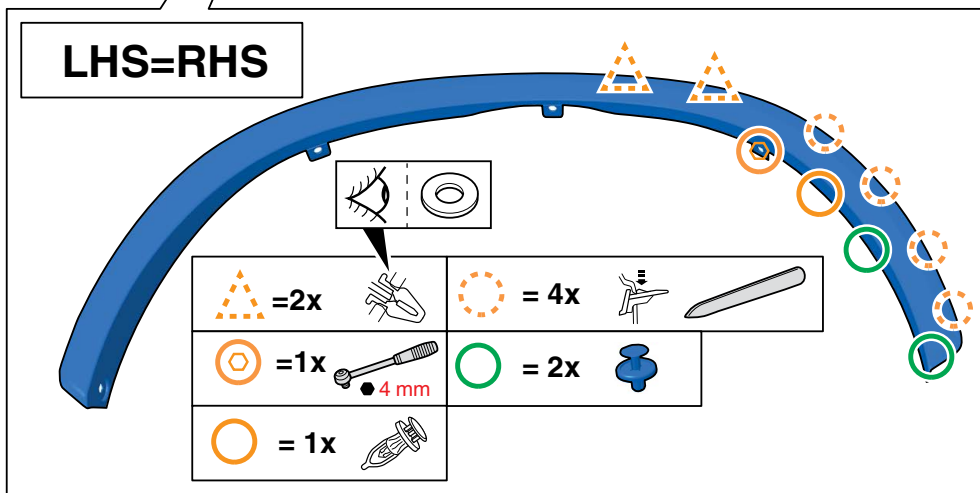
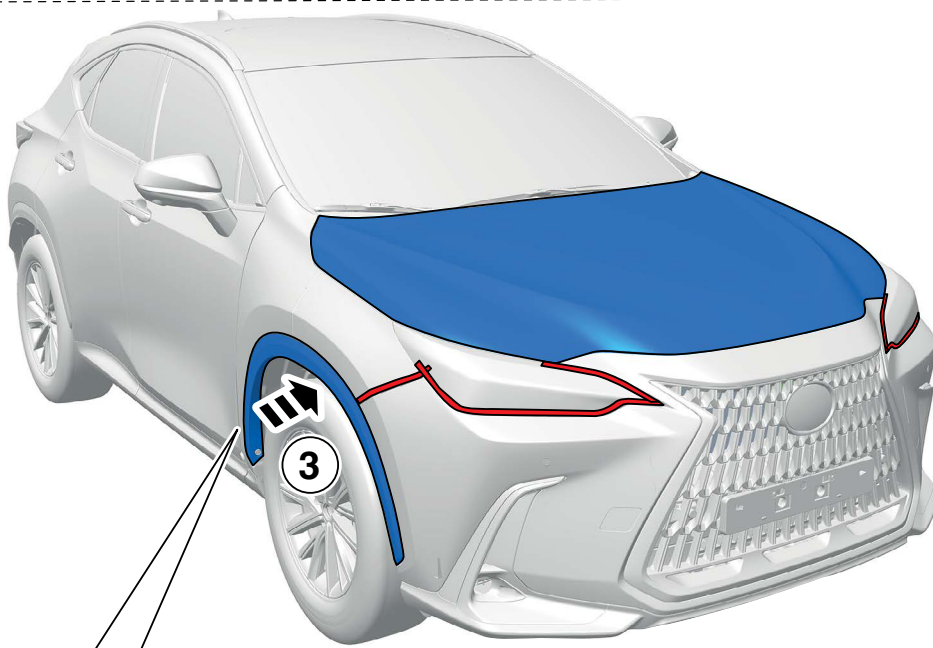
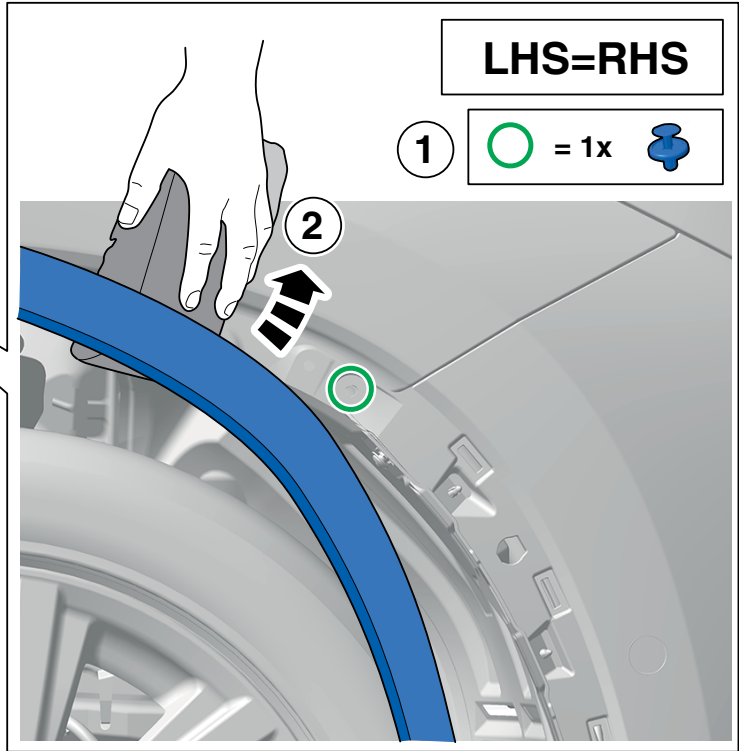
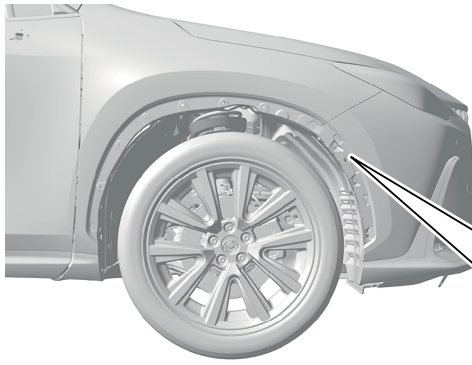

20

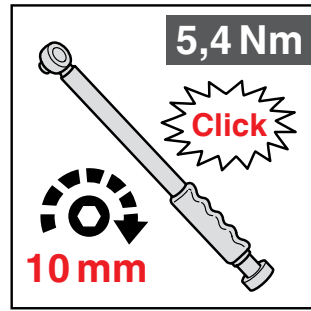
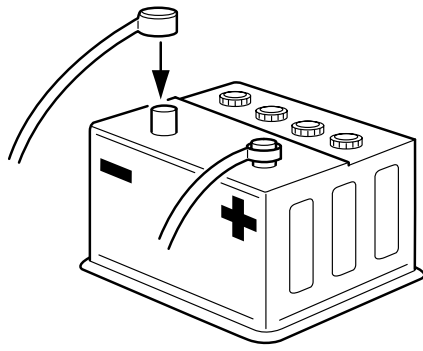

21

GENERAL



Info

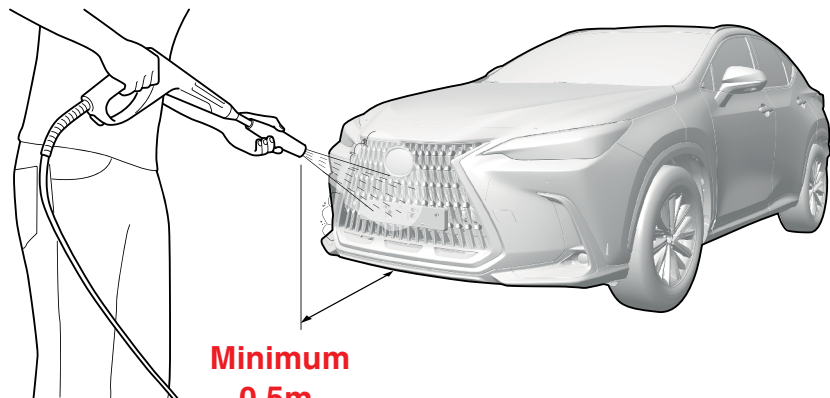
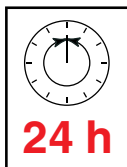
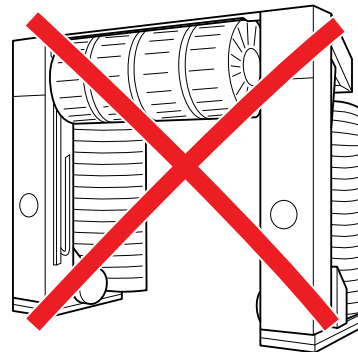
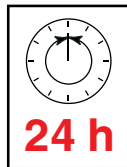

CHECK SHEET

Model/Year **NX** As from **2021/09** Front bumper garnish

VIN n°

DURING INSTALLATION

1

P/N = OK

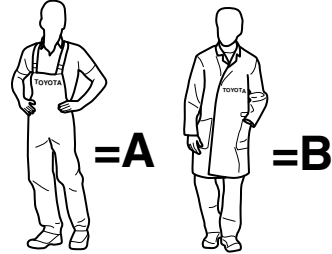

2

PUSH PULL PUSH

Click



3

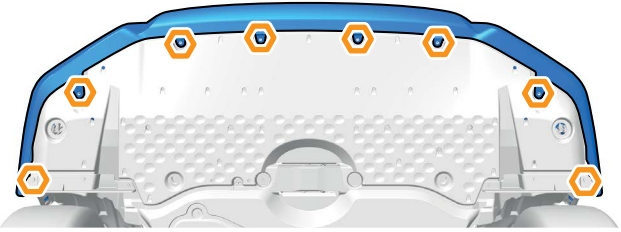

Y1

A Q

4







 

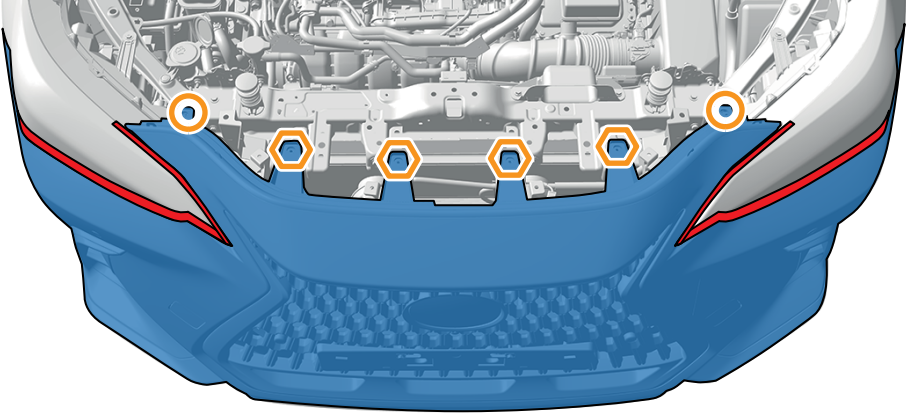

 = 8x  10 mm

5



 = 4x  10 mm

 = 2x 

6



 **Click**

Serial Number

5,4 Nm

 

AFTER INSTALLATION

1

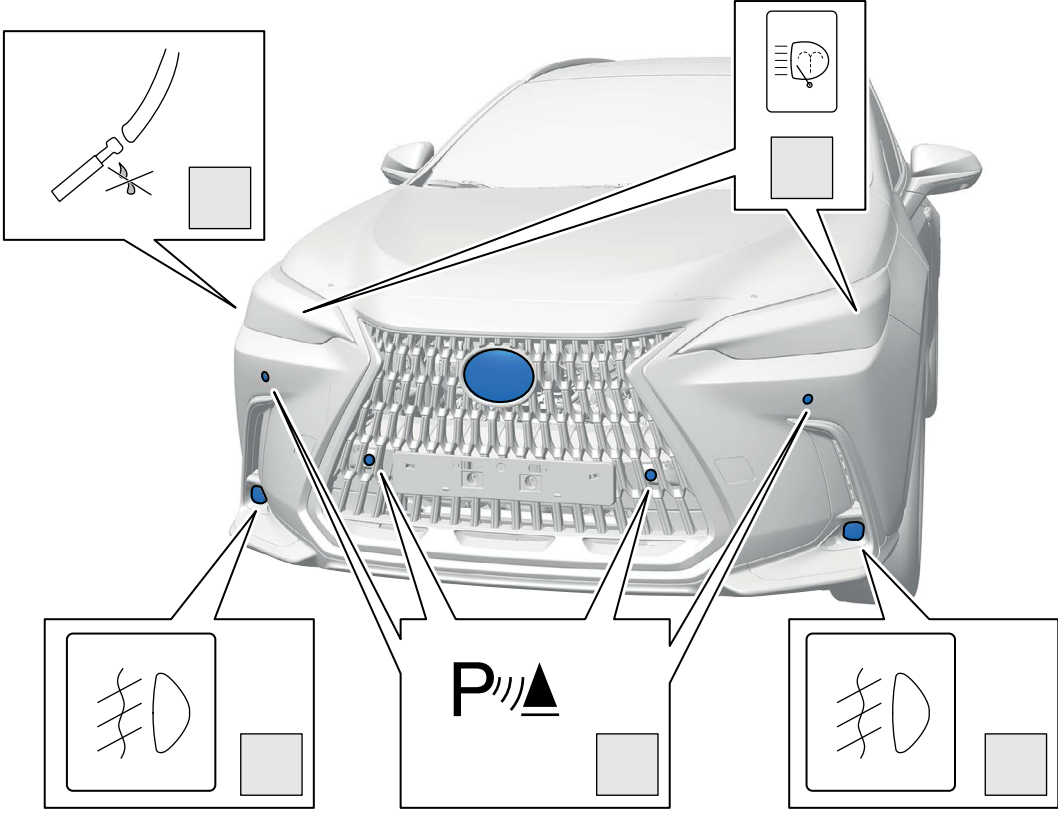

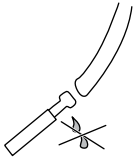

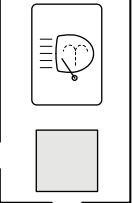

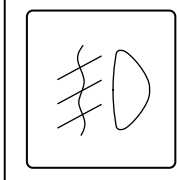

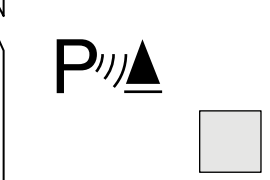

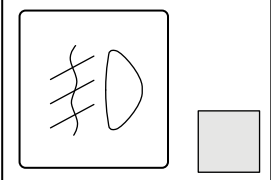

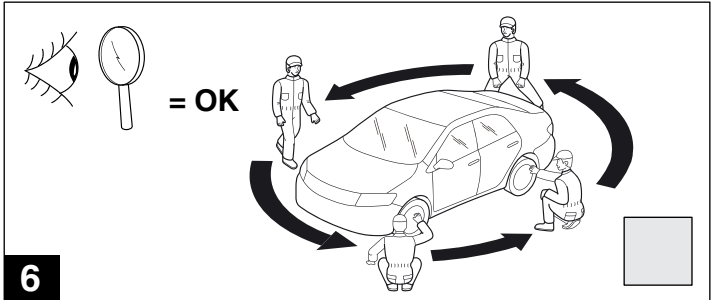
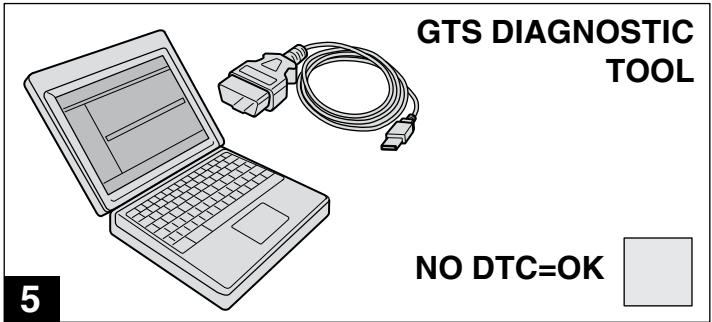
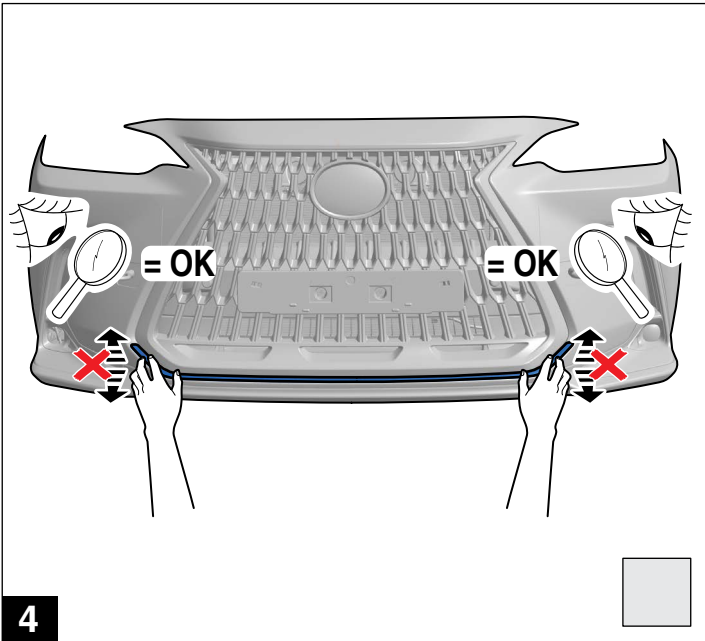
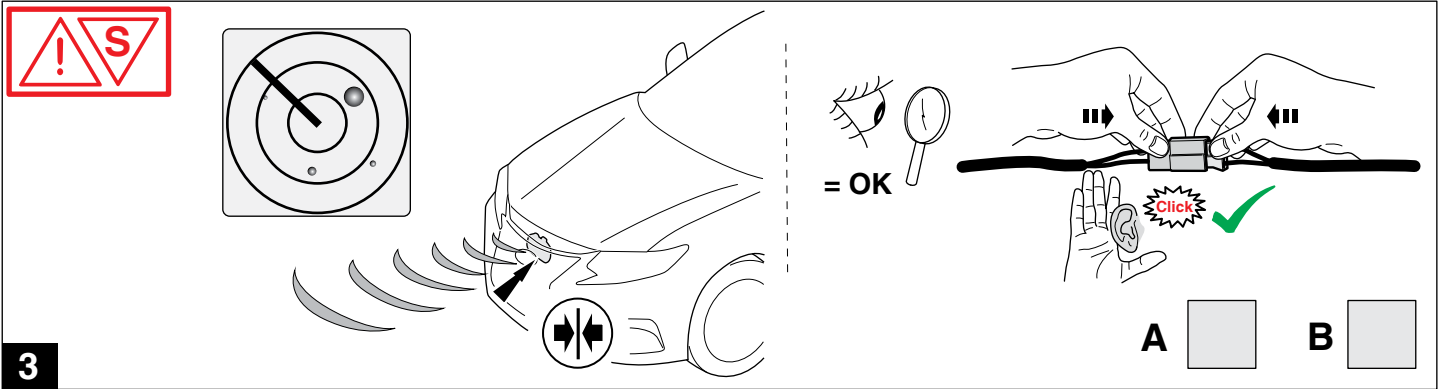
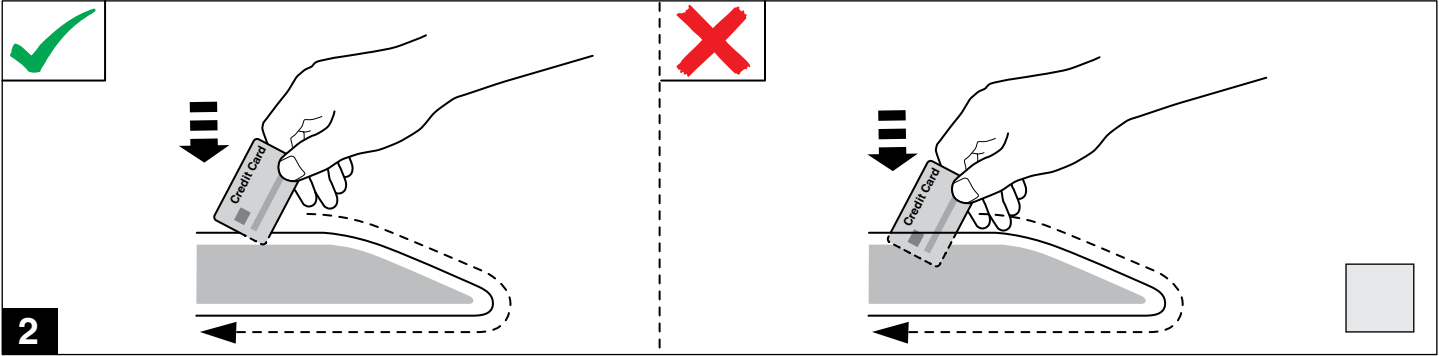

Installation Date:
. . / . . /

Technician Name & Signature:

Stamp: