

ICE

IN-CAR ENTERTAINMENT SYSTEM

INSTALLATION INSTRUCTIONS

COROLLA VERSO

	PART NUMBER
Headrest base kit	PZ462-E8371-00
DVD kit (optional)	PZ462-E8370-00
Bracket kit DVD (optional)	PZ425-E8370-60
ICE conversion wire	PZ457-00370-00
Security Cover, Dark Grey (optional)	PZ452-00370-B0

RHD

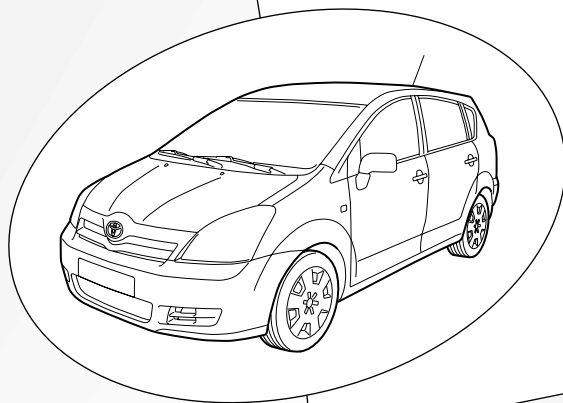

GB

- Expert Fitment Required.
- Disconnect the battery earth cable.
- To avoid damage to the wiring harness, ensure contact with sharp edges is prevented.
- Install parts as shown on illustrations.
- Re-connect battery.
- Re-fit panels, ensure that the wiring harness and other components are neatly and securely located.

D

- Montage durch Fachwerkstatt erforderlich.
- Massekabel von Batterie abklemmen.
- Zur Vermeidung von Beschädigungen an der Kabelisolation ist Berührung mit scharfen Kanten zu vermeiden.
- Teile gemäß Abbildung montieren.
- Batterie wieder anschließen.
- Paneele wieder anbringen; achten Sie darauf, daß der Kabelbaum und andere Teile ordnungsgemäß und genau positioniert sind.

E

- Montaje sólo por el concesionario.
- Desconectar el cable de masa de la batería.
- A efectos de evitar desperfectos en el aislamiento del cable, hay que evitar el contacto con aristas cortantes.
- Montar las piezas tal como se indica en las figuras.
- Vuelva a conectar la batería.
- Volver a colocar los paneles; preste atención a que el mazo del cable y las demás piezas tengan la posición correcta y precisa.

F

- Montage par spécialiste nécessaire.
- Débrancher le câble de masse de la batterie.
- Eviter tout contact avec des arêtes vives afin de ne pas endommager l'isolation des câbles.
- Monter les pièces selon les figures.
- Reconnecter la batterie.
- Remettre le panneau; veillez à ce que le faisceau et les autres pièces soient positionnés correctement et avec la précision requise.

I

- E' necessario in officina specializzata.
- Staccare il cavo di massa dalla batteria
- Allo scopo di evitare danni all'isolazione dei cavi, evitare di metterli a contatto con spigoli acuti.
- Montare le parti secondo quanto rilevabile delle illustrazioni.
- Riconnettere la batteria.
- Rimettere in posizione i pannelli; far ben attenzione che il fascio di cavi e le altre parti siano state posizionate con esattezza e nella dovuta maniera.

P

- Especialista em montagem requerido.
- Separe o cabo de terra do acumulador.
- Para não se danificar a isolação dos cabos, é conveniente evitar-se contacto com arestas afiadas.
- Monte as partes conforme ilustrado.
- Recolocar a bateria
- Tornar a colocar os painéis; verificar se a árvore de cabos e outras peças estão na posição exacta e prescrita.

NL

- Montage door vakman nodig.
- Massakabel van accu losmaken.
- Ter vermindering van beschadiging aan de isolatie van de elektrokit dient contact met scherpe kanten te worden vermeden.
- Delen overeenkomstig afbeelding monteren.
- Accu weer aansluiten.
- Panelen weer monteren; let erop, dat de kabelboom en andere delen correct en netjes gepositioneerd worden.

DK

- Montage ved professionelt værksted påkrævet.
- Stelkabel fjernes fra batteri.
- Berøring med skarpe kanter skal undgås for at undgå beskadigelse af kabelisoleringen.
- Dele skal monteres i henhold til illustrationer.
- Tilslut batteri igen.
- Paneler fastgøres igen; vær opmærksom på, at kabelsamlingen og andre dele placeres korrekt og præcist.

N

- Nødvendig med montering fra fagverksted.
- Klem jordkabelen av batteriet.
- For å unngå skader på kabelisoleringen må berøring av skarpe kanter unngås.
- Monter alle deler i henhold til illustrasjonene.
- Tilkobl batteriet igjen.
- Monter panelene igjen, og pass på at kabelbunten og andre deler er anbrakt ordentlig og på riktig sted.

S

- Verkstadsmontage erfordras.
- Lossa stomkabeln från batteriet.
- För att förhindra skador på ledningarnas isolation skall berøring med vassa kanter undvikas.
- Montera detaljerna enligt figurerna
- Anslut batteriet igen.
- Sätt tillbaka panelerna igen; kontrollera noga att ledningsmattan och andra detaljer ligger på rätt plats.

FIN

- Asennus tarpeen merkkikorjaamossa.
- Erotta maadoitusjohto akusta
- Pidä huoli myös siitä, että kaapelointi on korin kiinnityksen myötäinen ja kiinnitetty huolellisesti muihin liikkuviin osiin.
- Asenna osat kuvien mukaan.
- Kytke akku takaisin.
- Aseta paneelit paikalleen; tarkista, että kaapelointi ja muut osat ovat asianmukaisesti ja tarkalleen paikoillaan.

CZ

- Montáž ve specializované dílně nutná.
- Odpojte zemnicí kabel od baterie.
- Zabraňte tomu, aby se kabely poškodily tím, že jsou položeny na ostrých hranách.
- Montujte části podle vyobrazení
- Opět připojit baterii.
- Opět připevněte panely; dbejte na to, aby svazek kabelů a ostatní části byly uloženy na správném místě.

H

- A szereléshez szakműhely kell.
- Húzza le az akkumulátor testkábeljét.
- A kábelszigetelés megsérülésének elkerülésére ügyeljen arra, hogy a kábel ne juthasson érintkezésbe éles peremű alkatrészekkel.
- Az alkatrészeket az ábrák szerint szerelje be.
- Ismét csatlakoztassa az akkumulátort.
- Szerelje vissza a fedőlapokat, ügyeljen arra, hogy a kábelek és a többi alkatrészek pontosan a számukra kijelölt helyen maradjanak.

PL

- Konieczny montaż przez warsztat specjalistyczny.
- Odłączyć przewód masy od akumulatora.
- Dla zapobieżenia uszkodzeniu izolacji chronić przed zetknięciem z ostrymi krawędziami.
- Zamontować części zgodnie z rysunkiem.
- Ponownie podłączyć akumulator.
- Na powrót osadzić osłony; zadbać aby wiązka kablowa i inne części były właściwie i dokładnie ułożone.

GR

- Να τοποθετεί από συνεργείο.
- Αποσυνδέστε το καλώδιο γείωσης από τη μπαταρία.
- Για να αποφευχθούν ζημιές στη μόνωση καλωδίων, να αποφεύγεται η επαφή των με αιχμηρές ακμές.
- Τοποθέτηση των μερών σύμφωνα με τις Εικόνες.
- Συνδέστε πάλι τη μπαταρία.
- Τοποθετήστε πάλι το κάλυμμα προσοχή, η πλεξούδα καλωδίων και άλλα μέρη να είναι τοποθετημένα ακριβώς και σύμφωνα με τους κανονισμούς.

PZ462-E8370-00

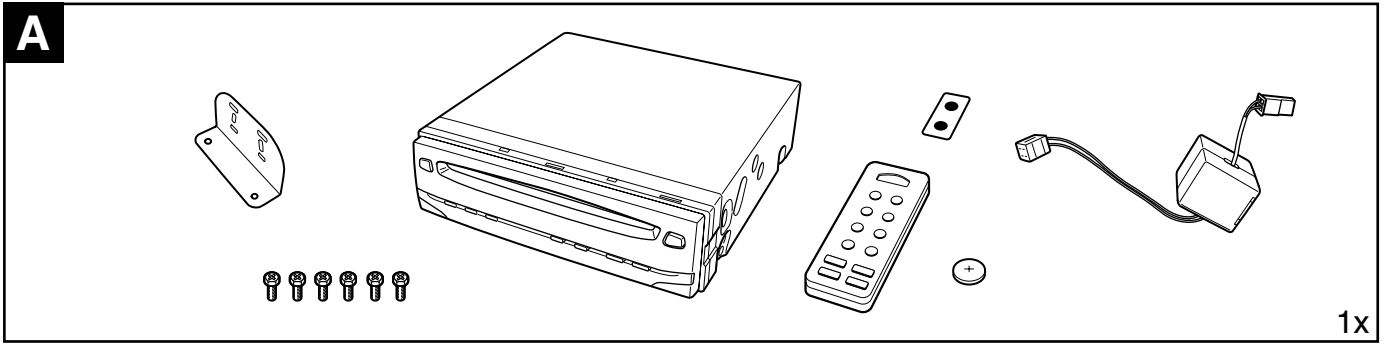

PZ425-E8370-60

PZ457-00370-00

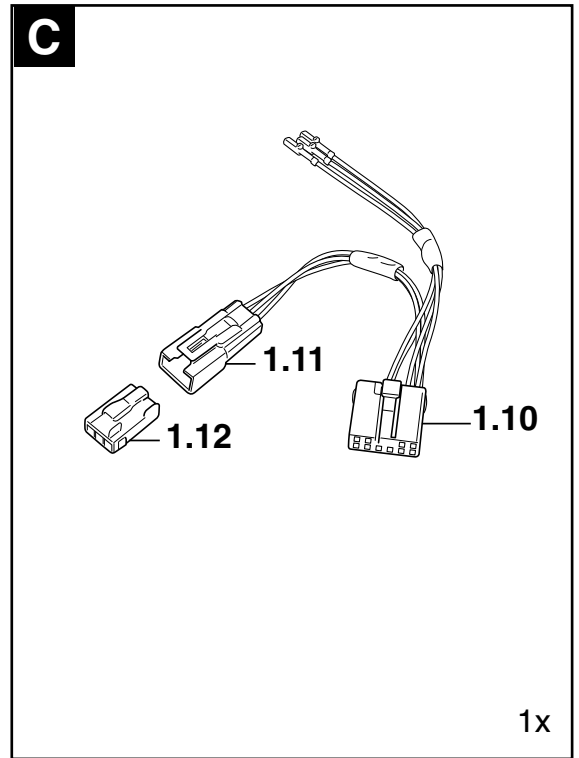
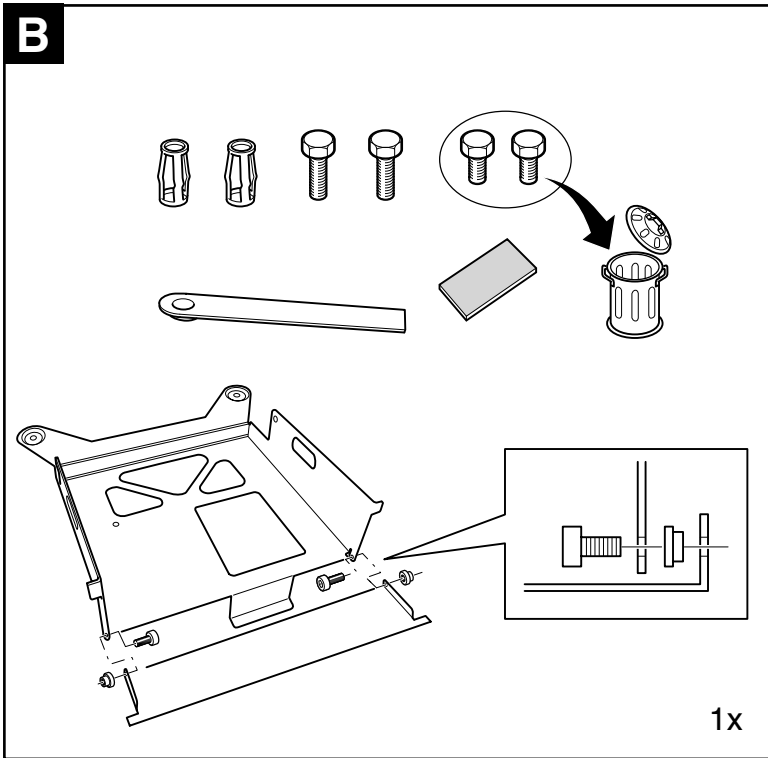



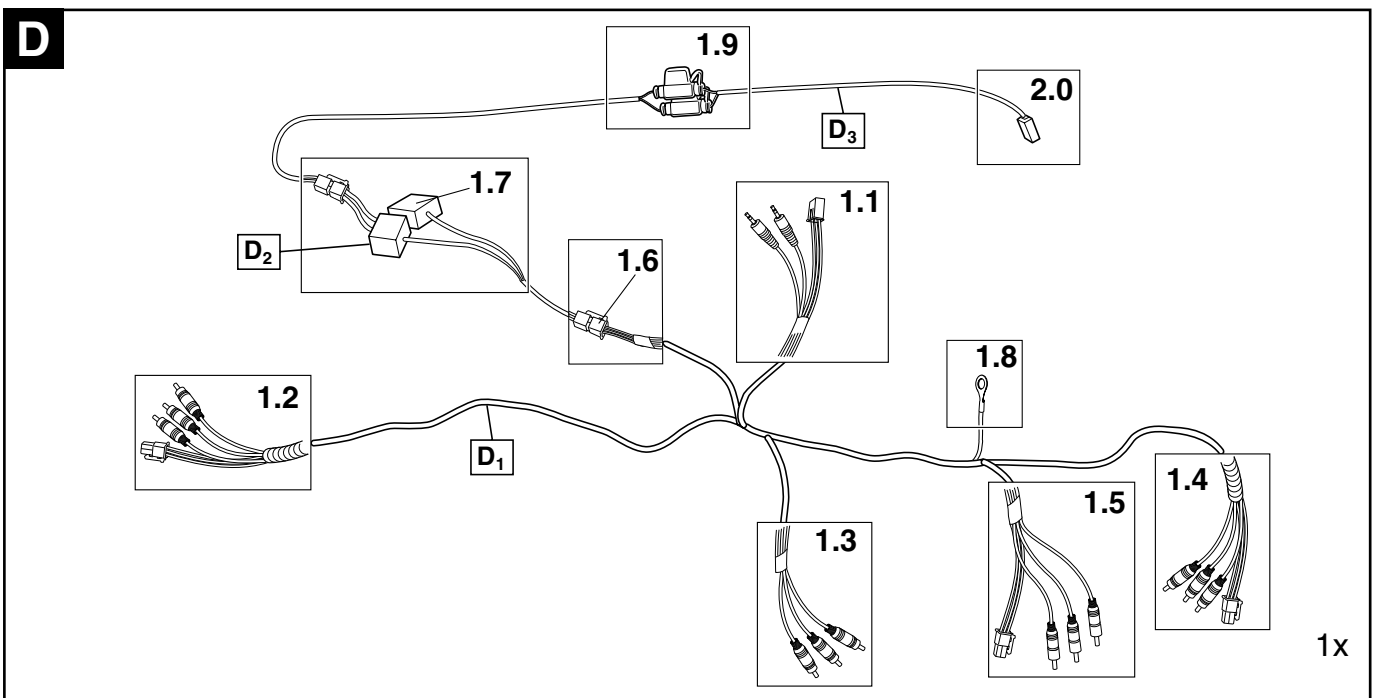

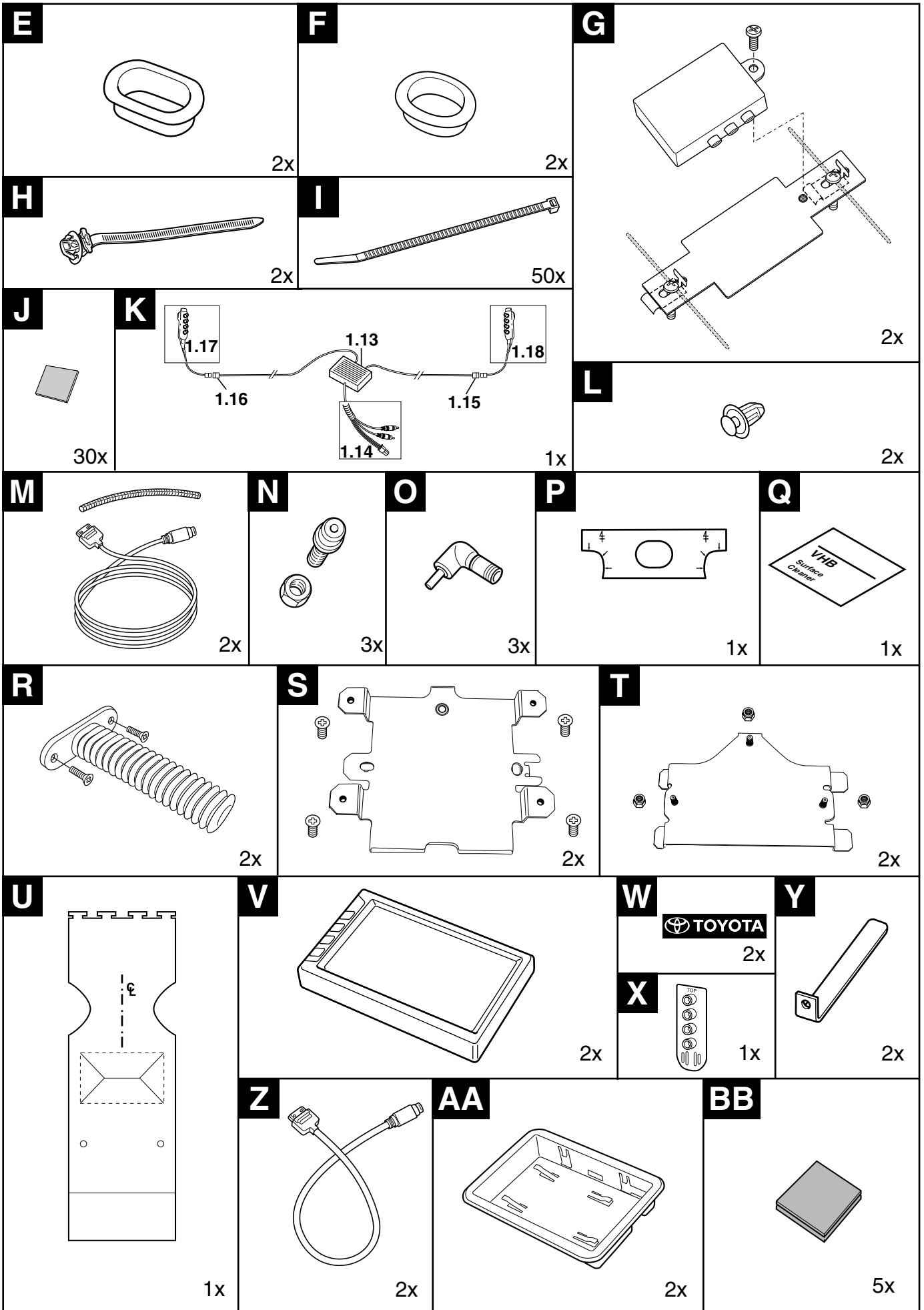



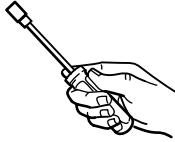
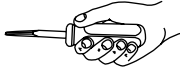

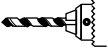
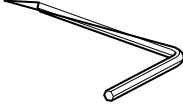

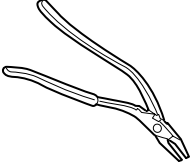

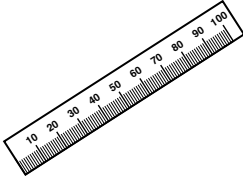

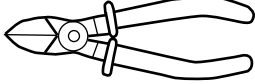
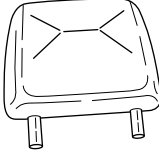
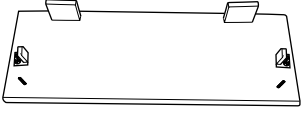
PZ462-E8371-00





TOOLS

			
			
	 5x		
			

	=	
	=	
	=	
	=	

	GB	D	E	F	I	P	NL	DK
L	Blue	Blau	Azul	Bleu	Blu	Azul	Blauw	Blå
B	Black	Schwarz	Negro	Noir	Nero	Preto	Zwart	Sort
BR	Brown	Braun	Marrón	Marron	Marrone	Castanho	Bruin	Brun
G	Green	Grün	Verde	Vert	Verde	Verde	Groen	Grøn
GR	Grey	Grau	Gris	Gris	Grigio	Cinzeno	Grijs	Grå
O	Orange	Orange	Naranja	Orange	Arancione	Laranja	Oranje	Orange
P	Pink	Rosa	Rosa	Rose	Rosa	Rosa	Rosé	Rosa
R	Red	Rot	Rojo	Rouge	Rosso	Vermelho	Rood	Rød
W	White	Weiß	Blanco	Blanc	Bianco	Branco	Wit	Hvid
Y	Yellow	Gelb	Amarillo	Jaune	Giallo	Amarelo	Geel	Gul
V	Violet	Violett	Violeta	Violet	Viola	Violeta	Violet	Violet

	N	S	SF	CZ	H	PL	GR
L	Blå	Blå	Sininen	Modrá	Kék	Niebieska	Μπλε
B	Sort	Svart	Musta	Černá	Fekete	Czarna	Μαύρο
BR	Brun	Brun	Ruskea	Hnědá	Barna	Brązowa	Καφέ
G	Grønn	Grøn	Vihreä	Zelená	Zöld	Zielona	Πράσινο
GR	Grå	Grå	Harmaa	Šedá	Szürke	Szara	Γκρι
NO	Naturfarger	Naturfärger	Luonnonväri	Přírodní barva	Természetes színű	Barwy naturalne	Φυσικά χρώματα
O	Orange	Orange	Oranssi	Oranžová	Narancs	Pomarańczowa	Πορτοκαλί
P	Rosa	Rosa	Rosa	Růžová	Rózsaszín	Różowa	Ροζ
R	Rød	Röd	Punainen	Červená	Piros	Czerwona	Κόκκινο
W	Hvit	Vit	Valkoinen	Bílá	Fehér	Biała	Λευκό
Y	Gul	Gul	Keltainen	Žlutá	Sárga	Żółta	Κίτρινο
V	Fiolett	Violett	Violetti	Fialová	Ibolyakék	Fioletowa	Μοβ

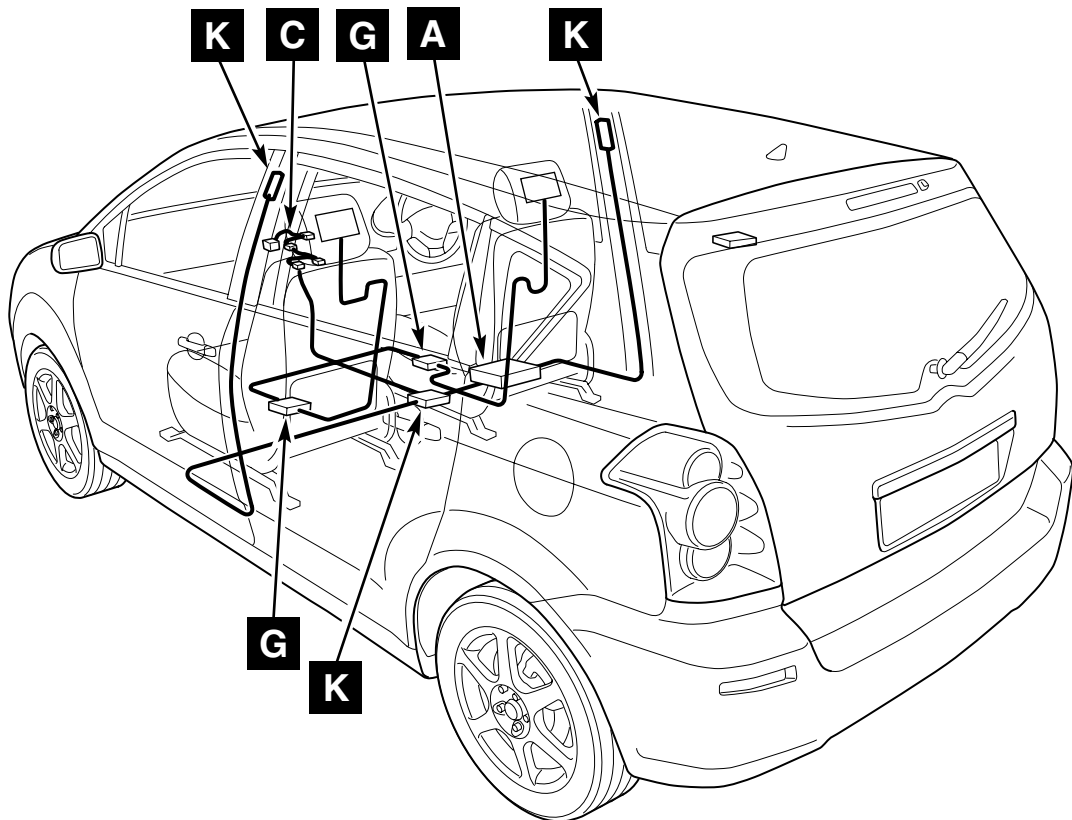

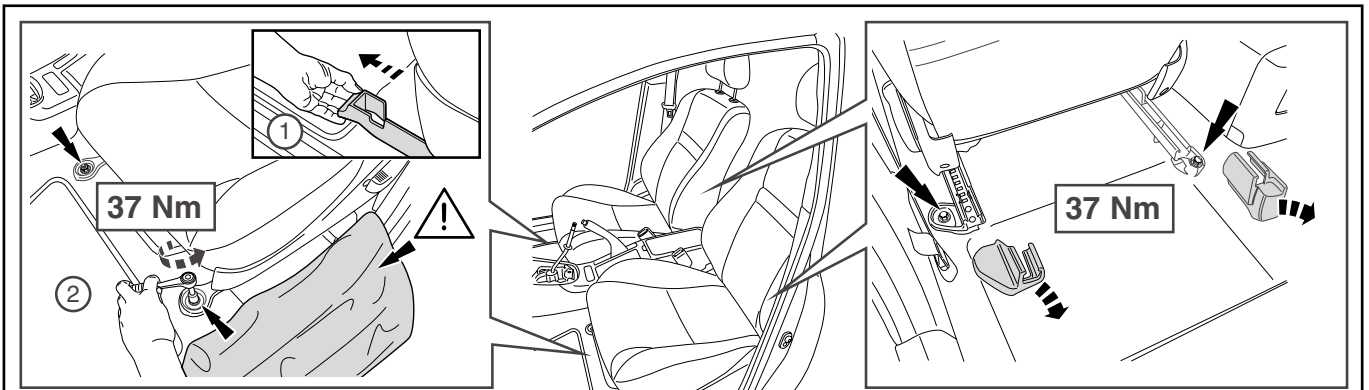

1

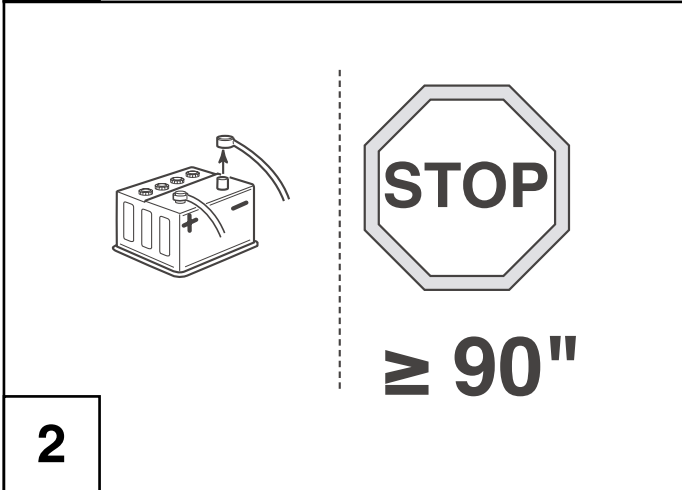

2

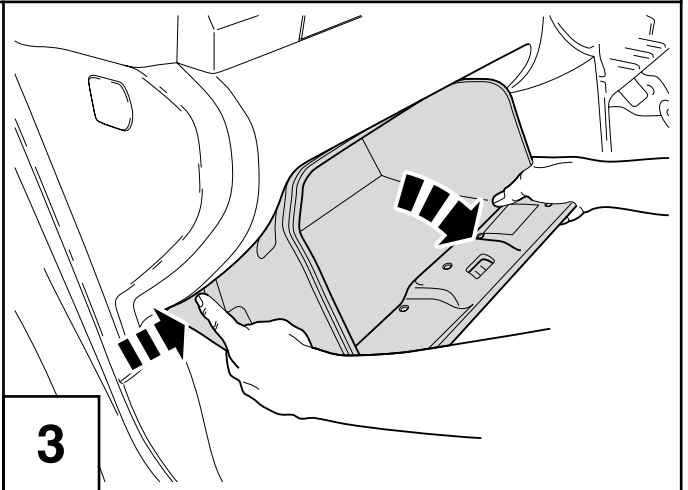

3

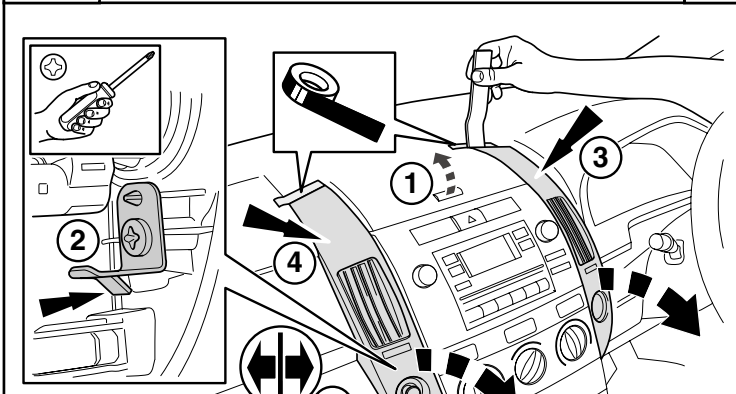

4

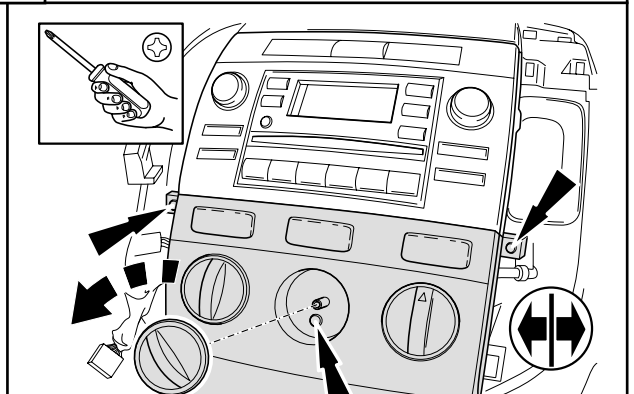

5

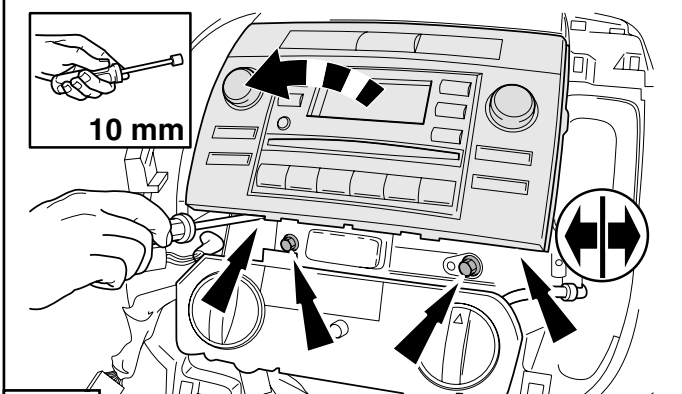

6

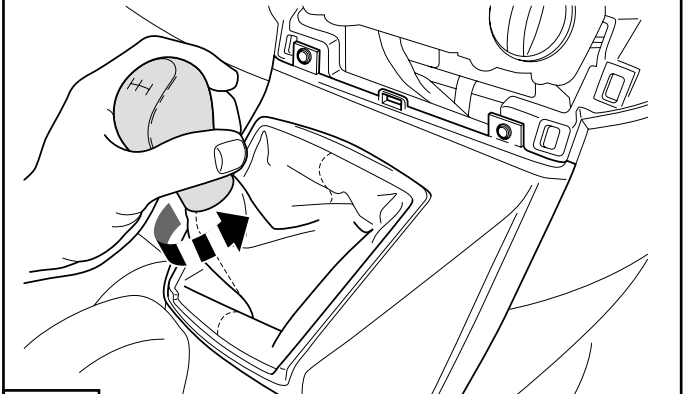

7

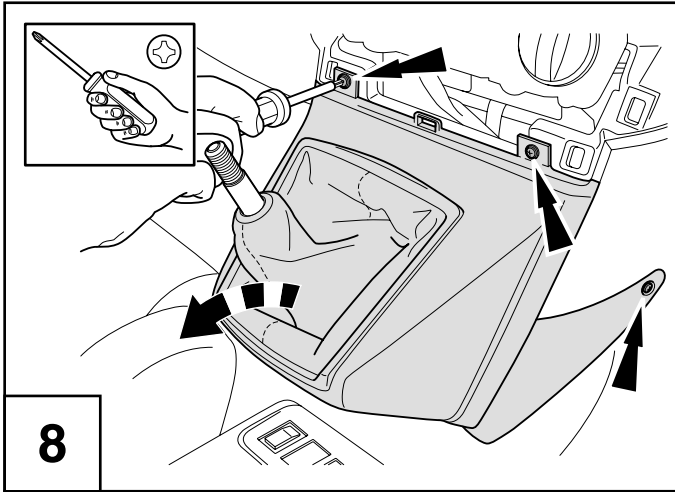

8

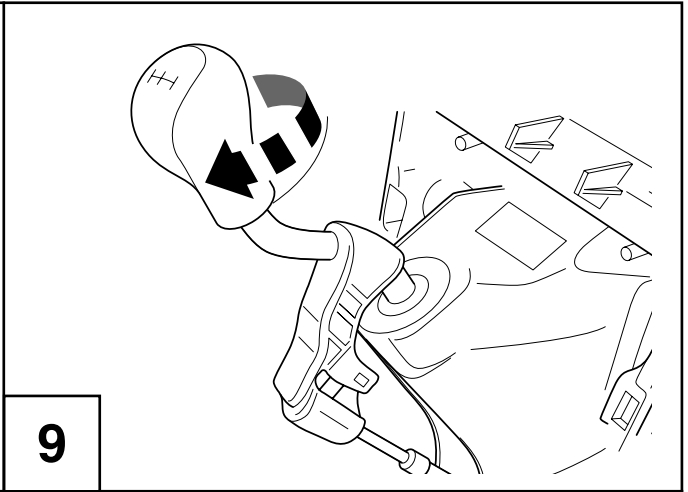

9

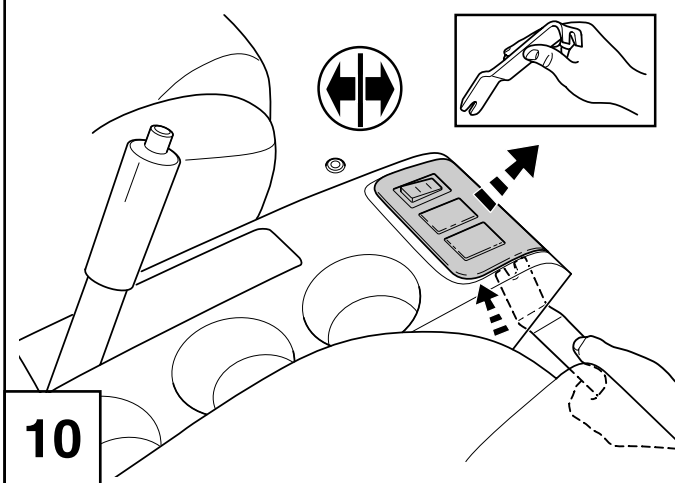

10

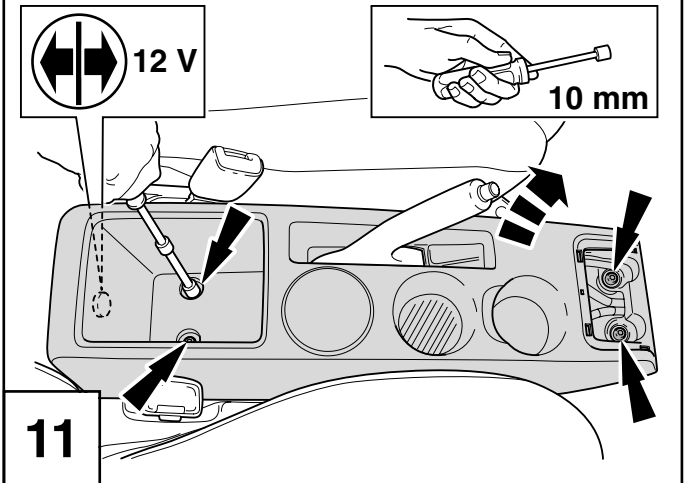

11

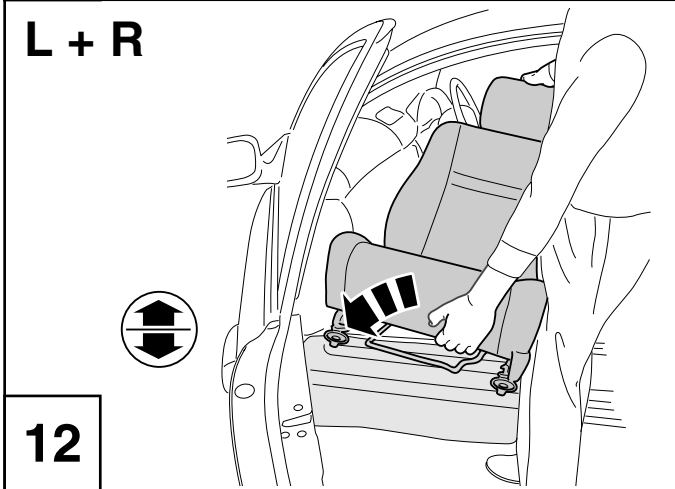

12

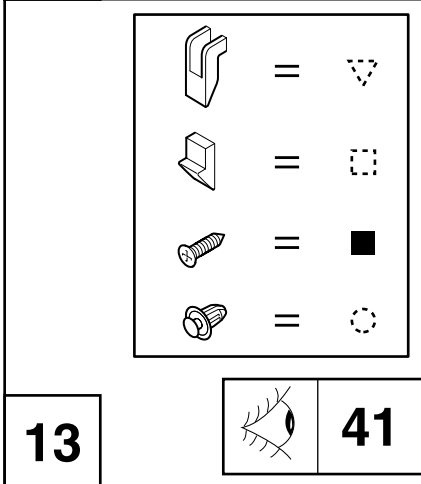
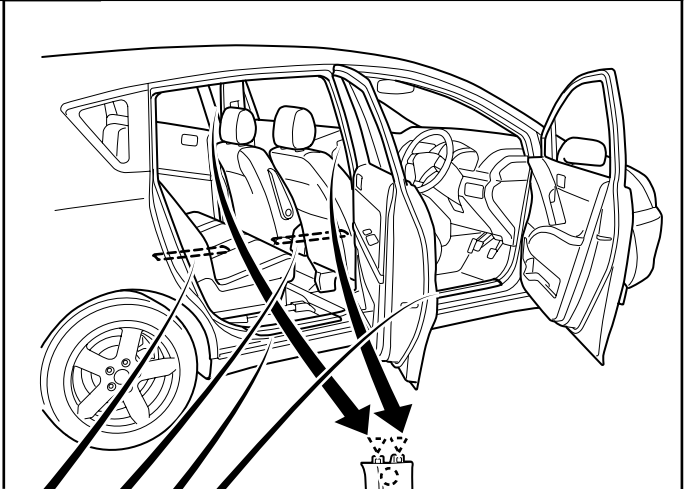

13

41

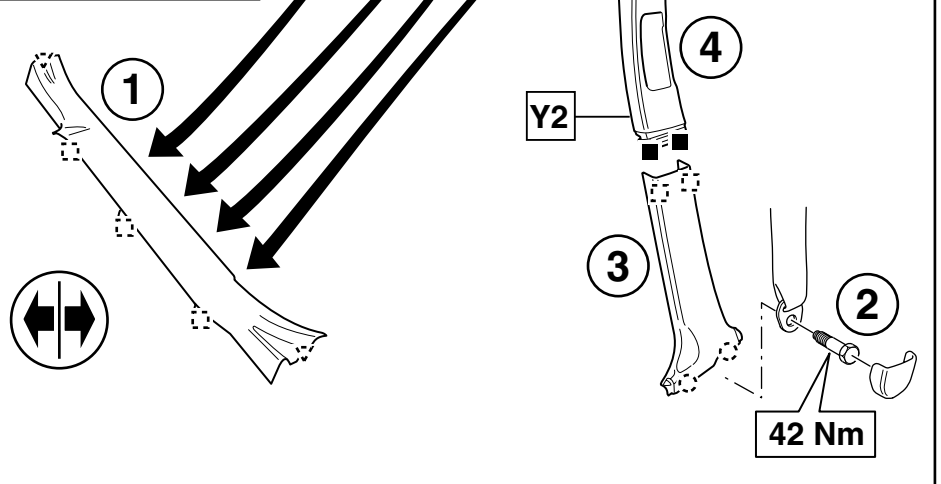

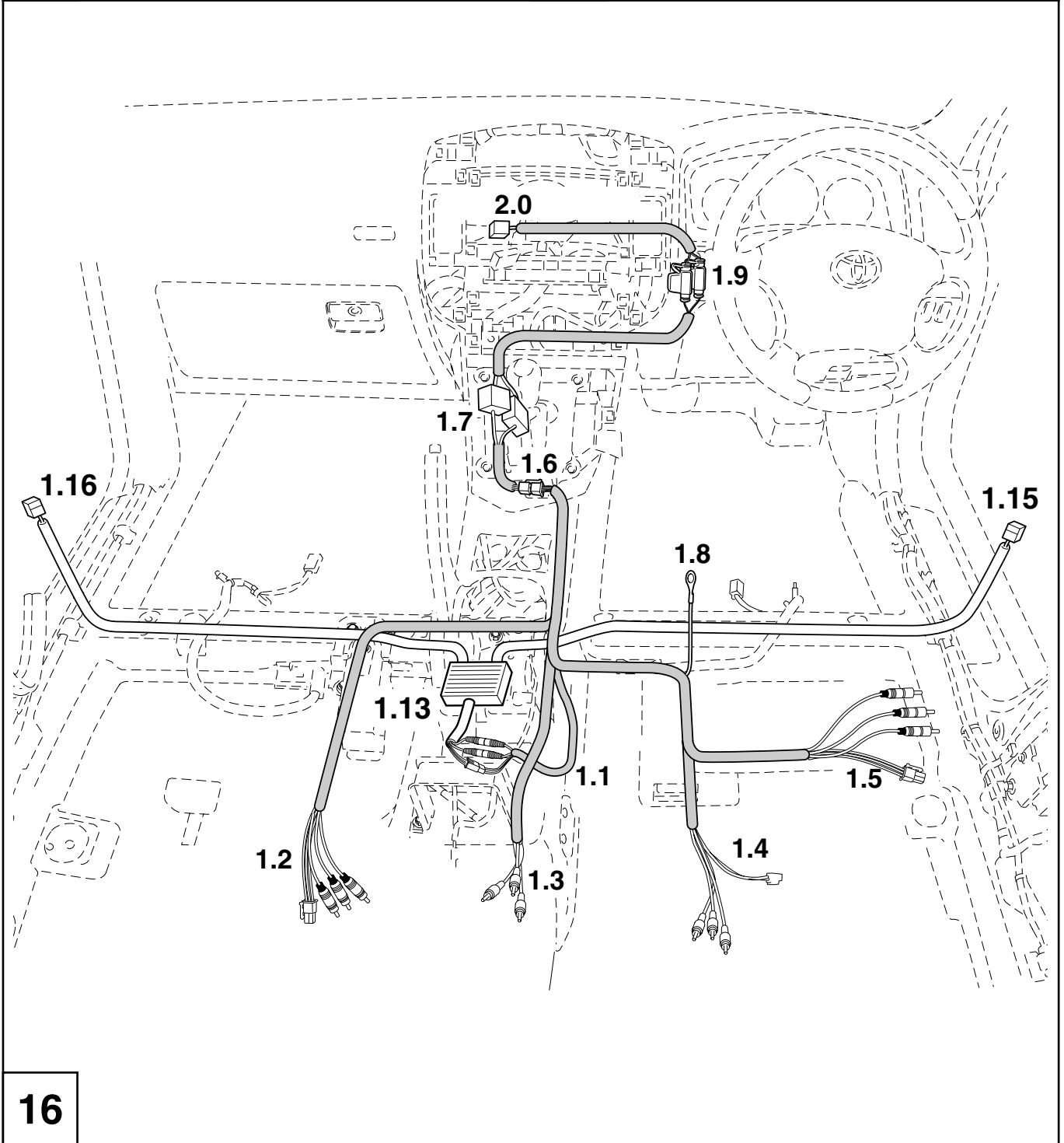
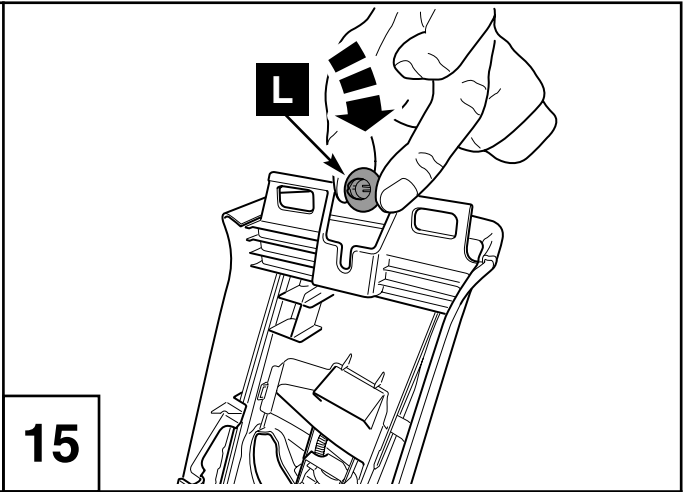
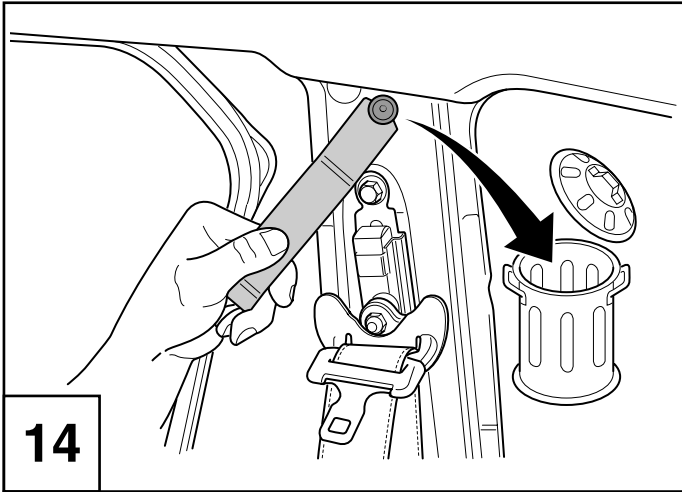

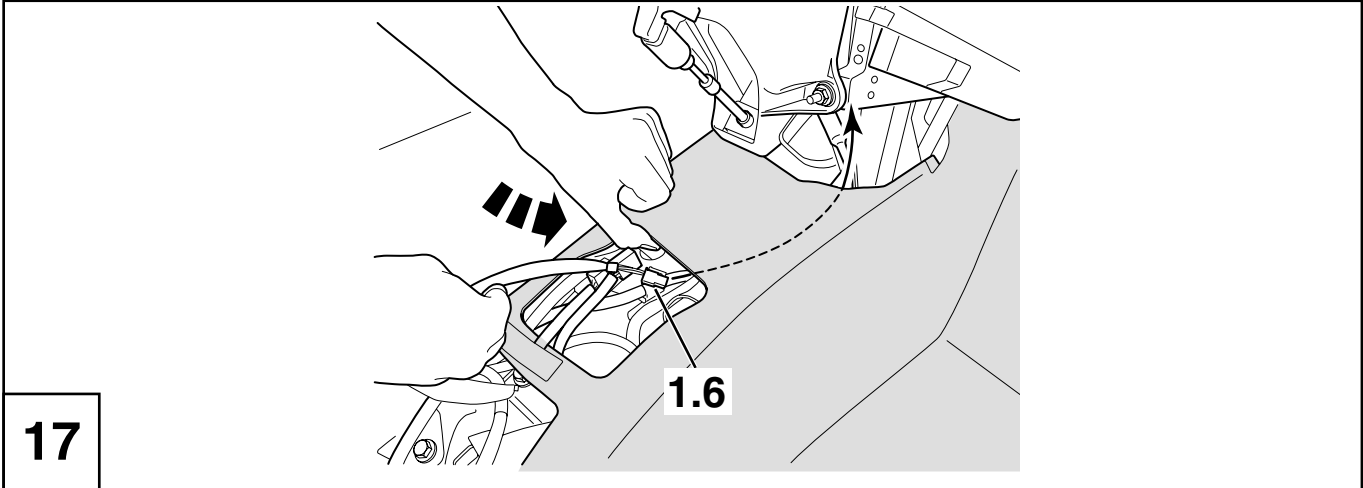

17

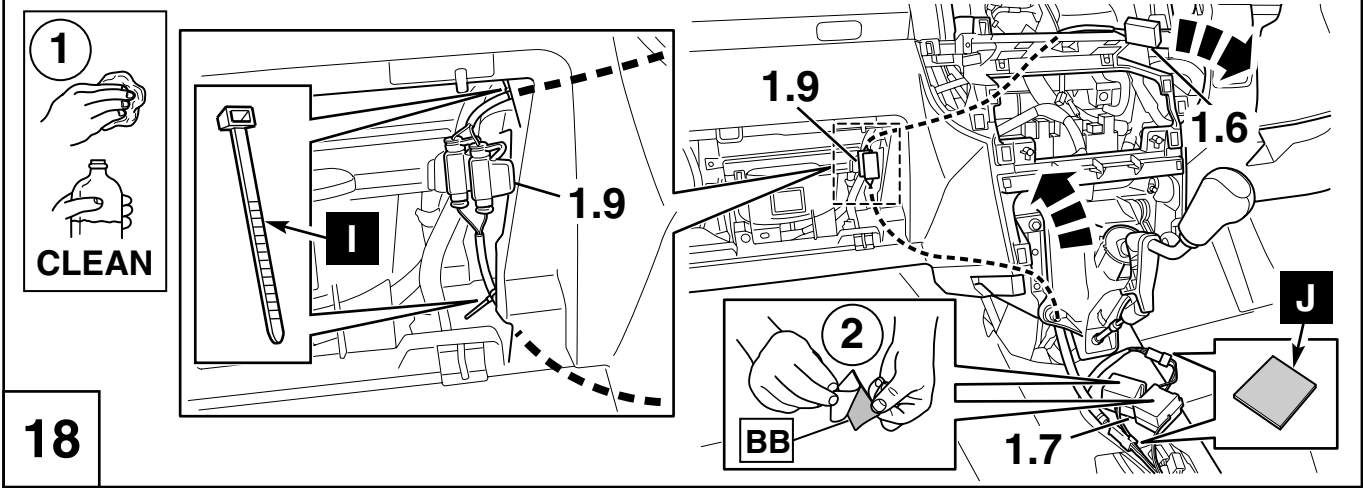

18

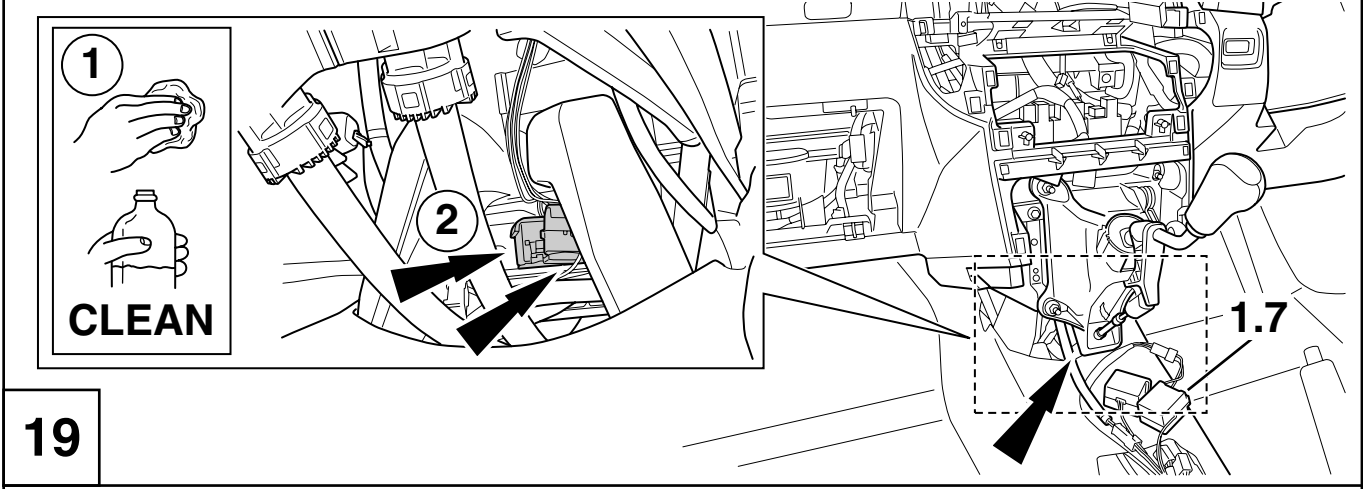

19

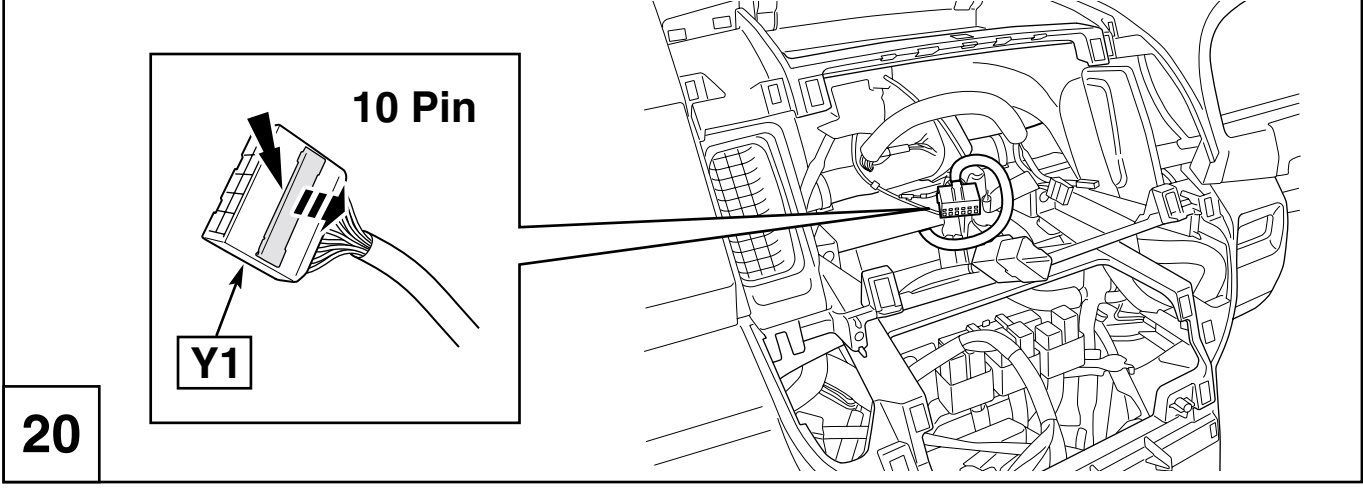

20

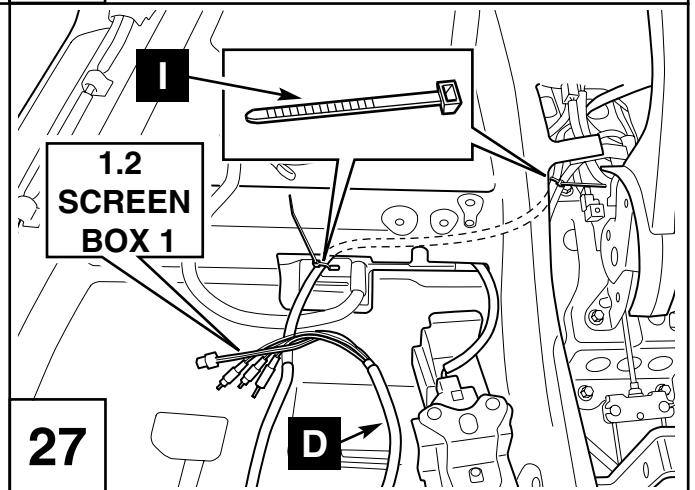
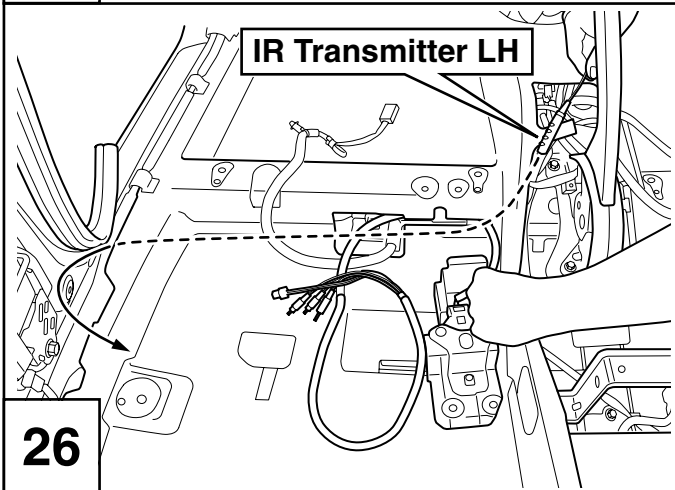
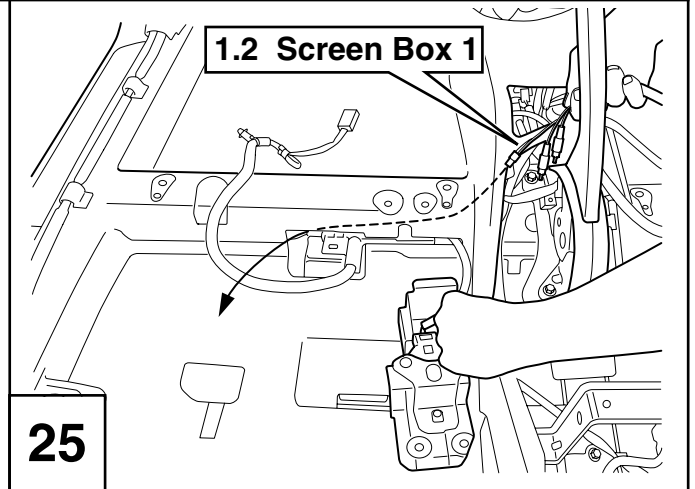
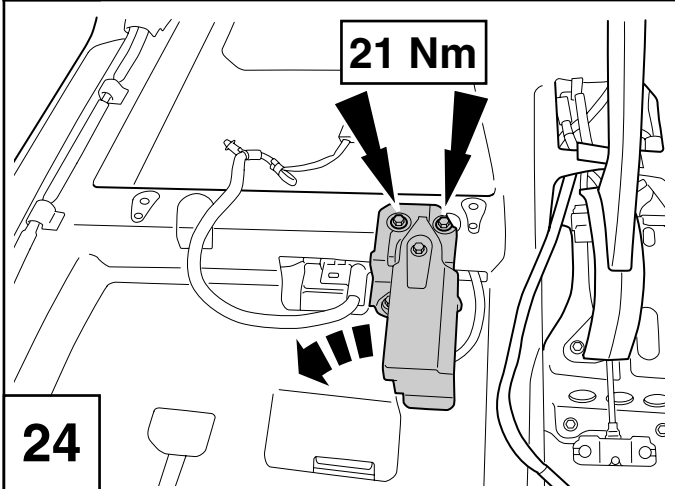
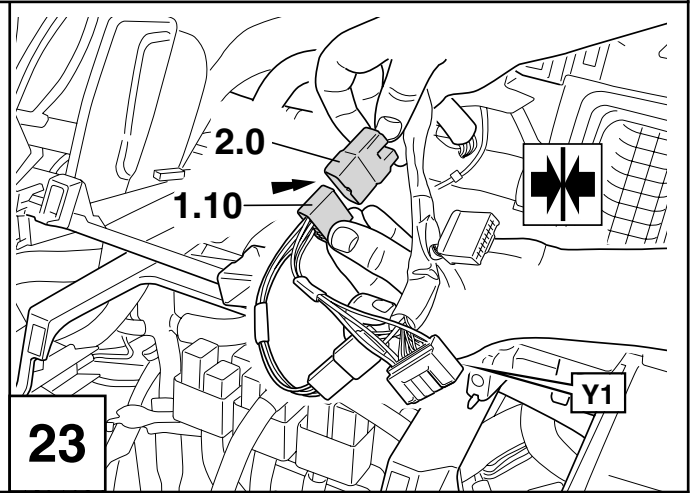
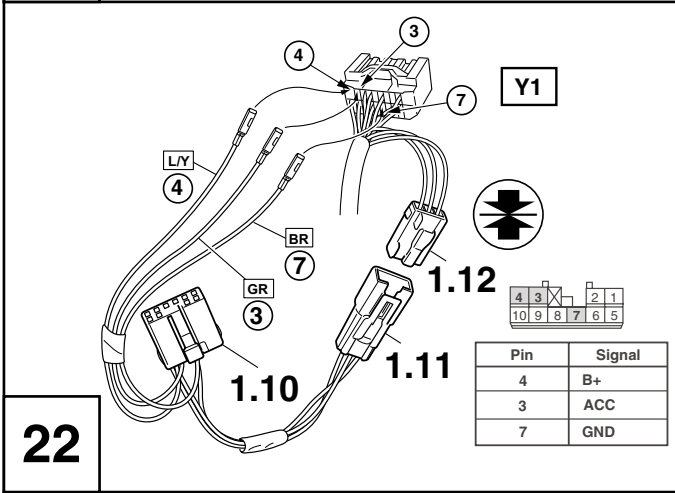
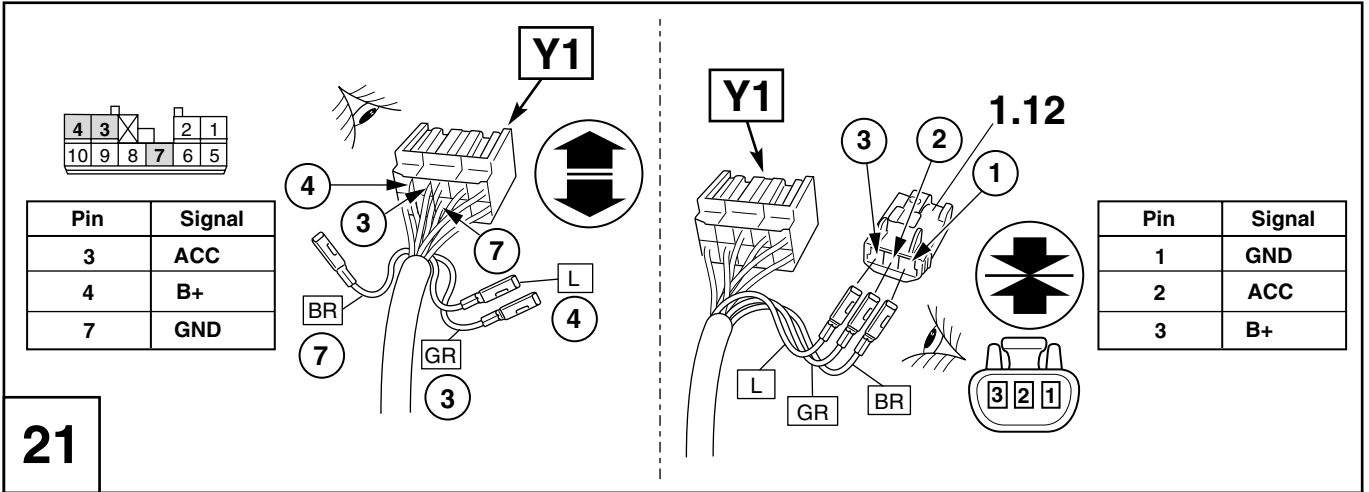

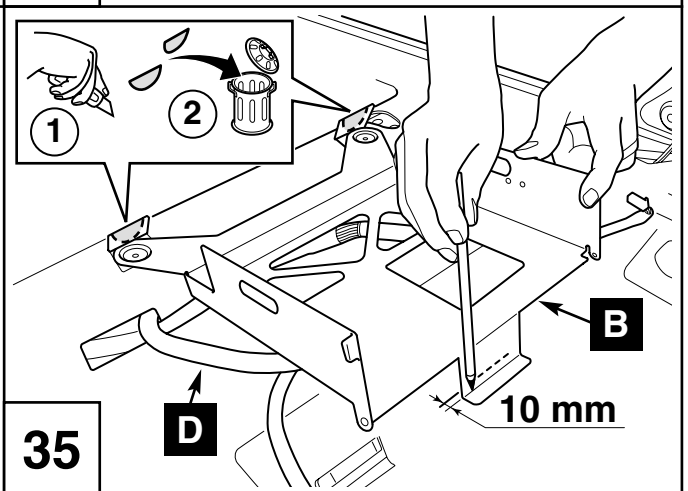
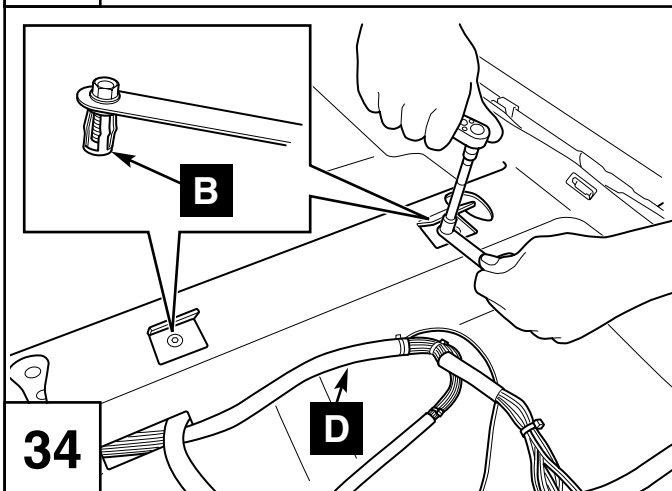
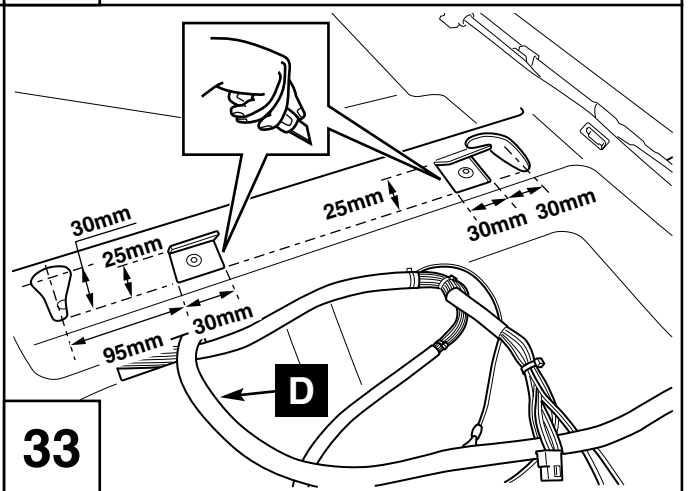
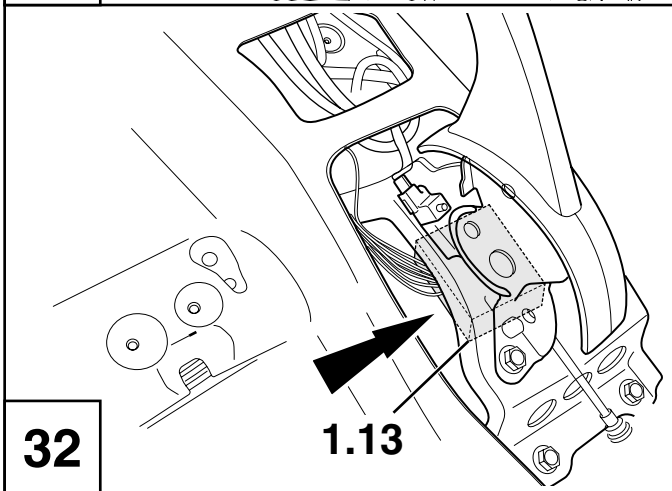
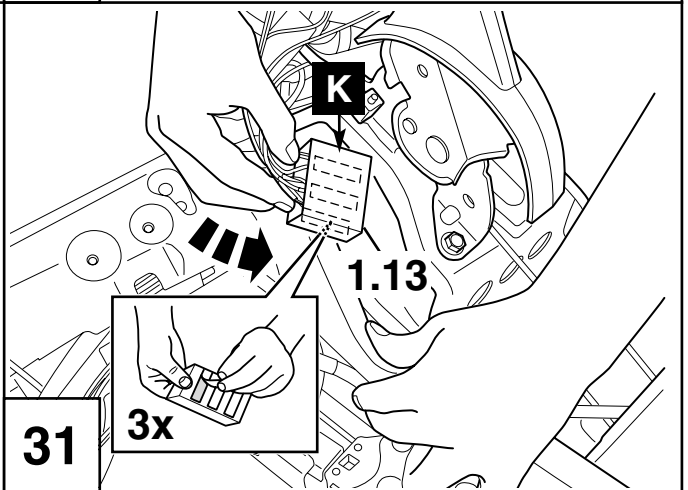
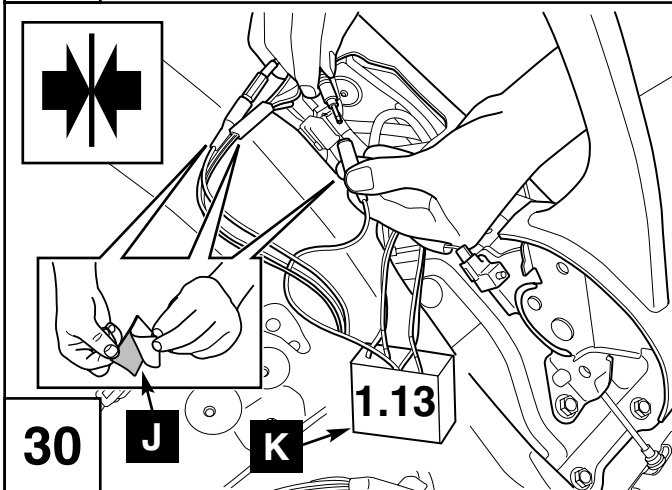
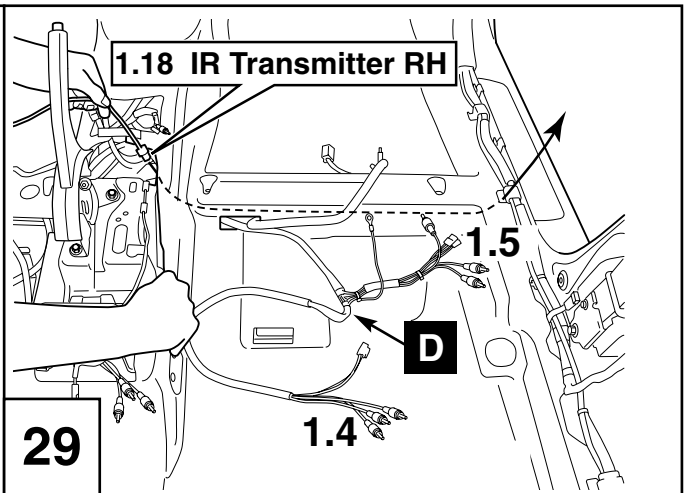
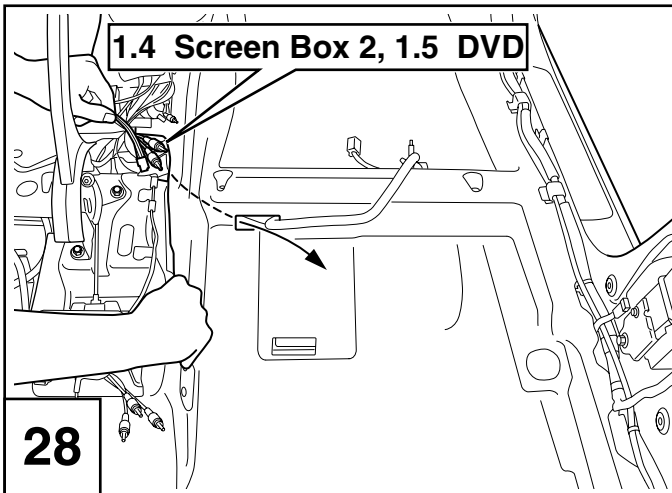

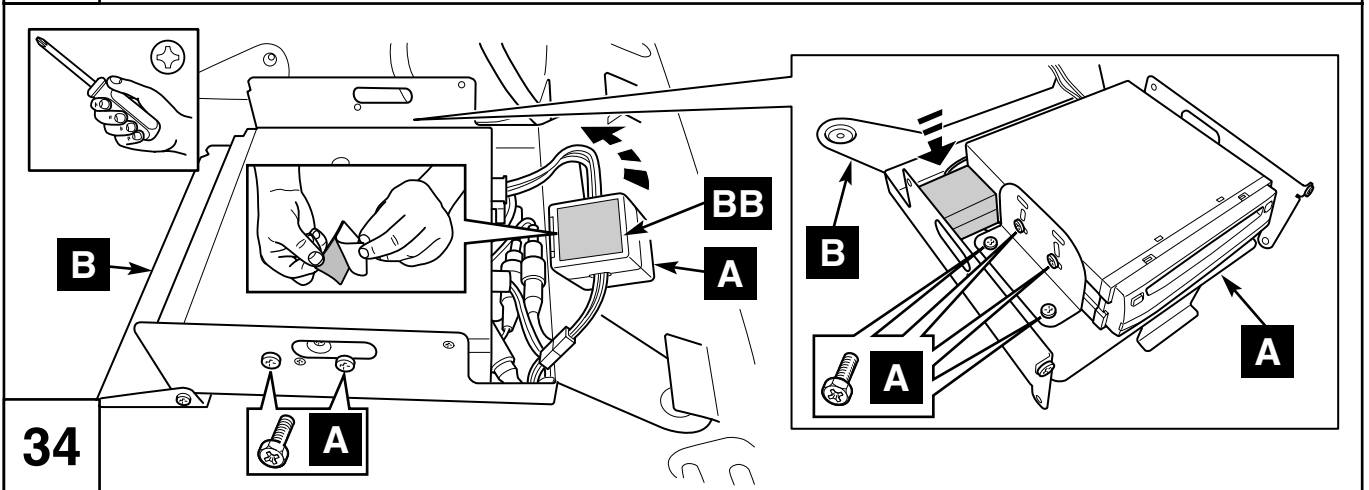
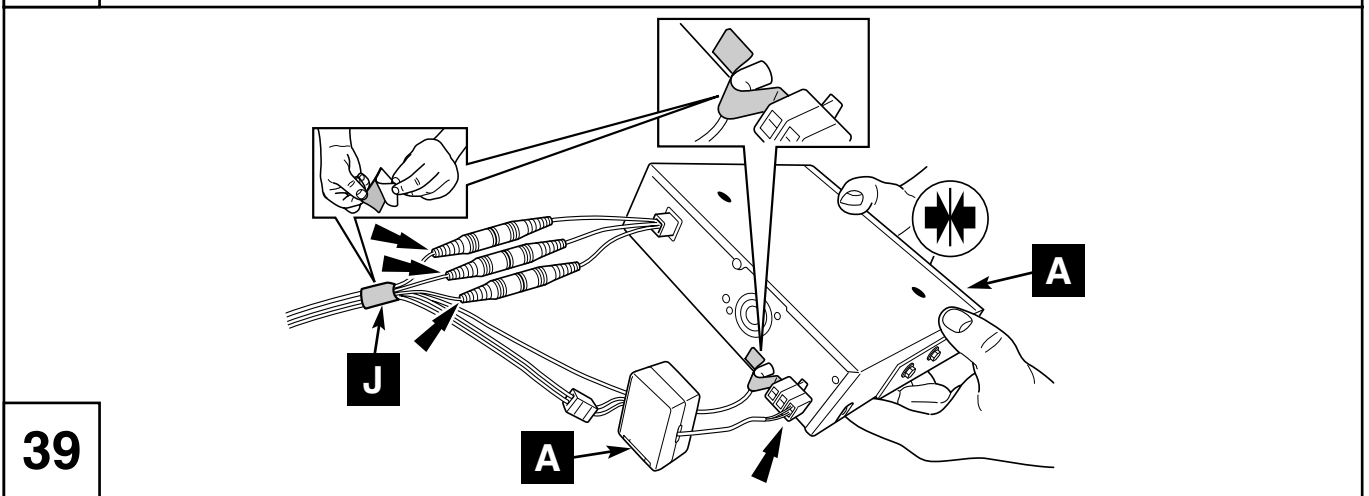
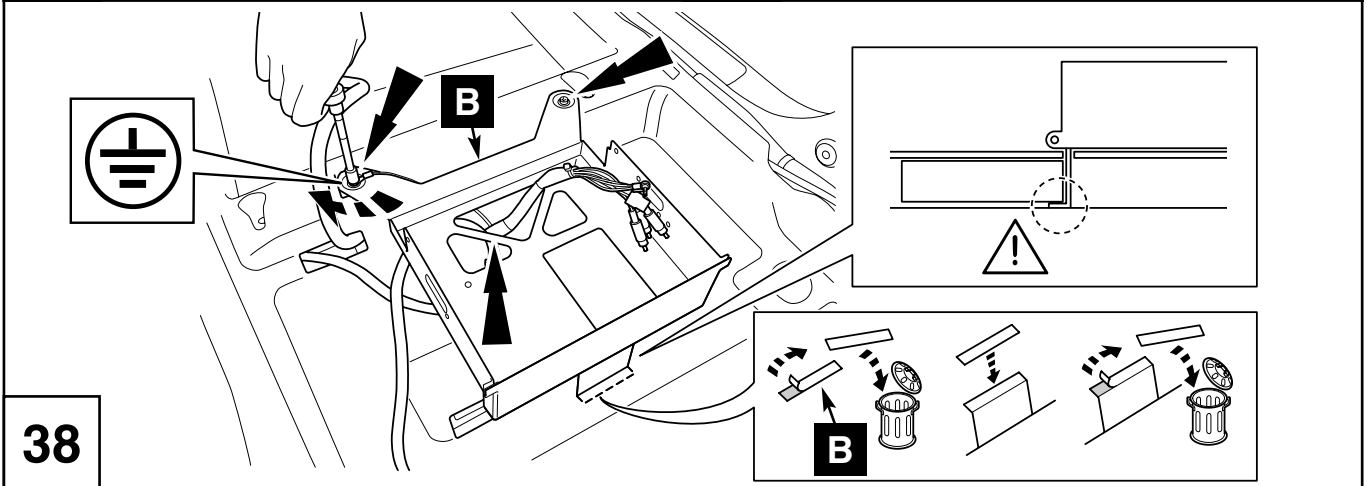
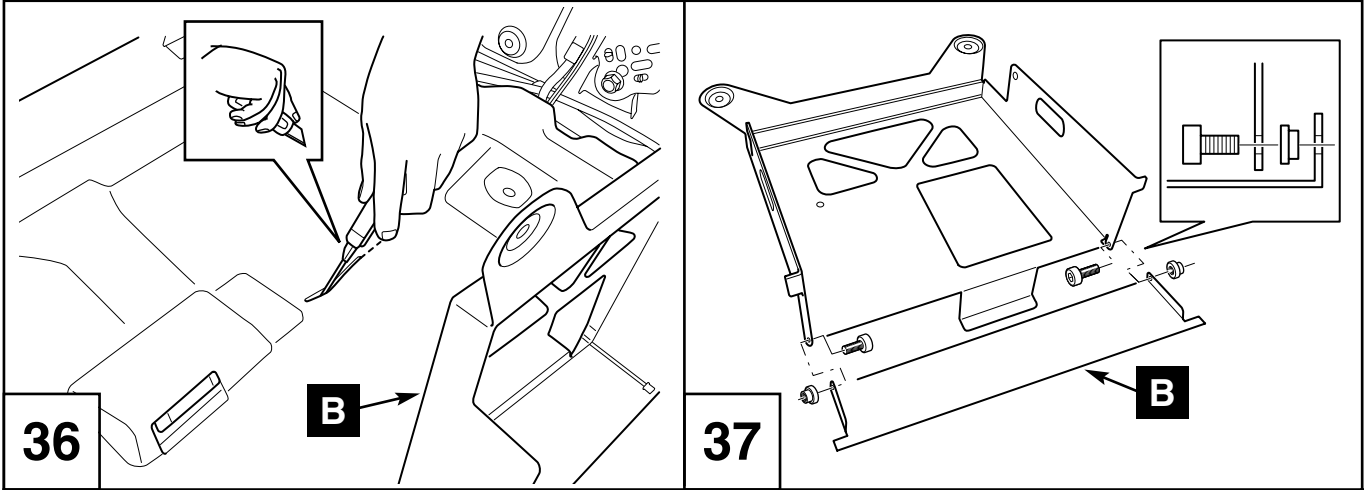

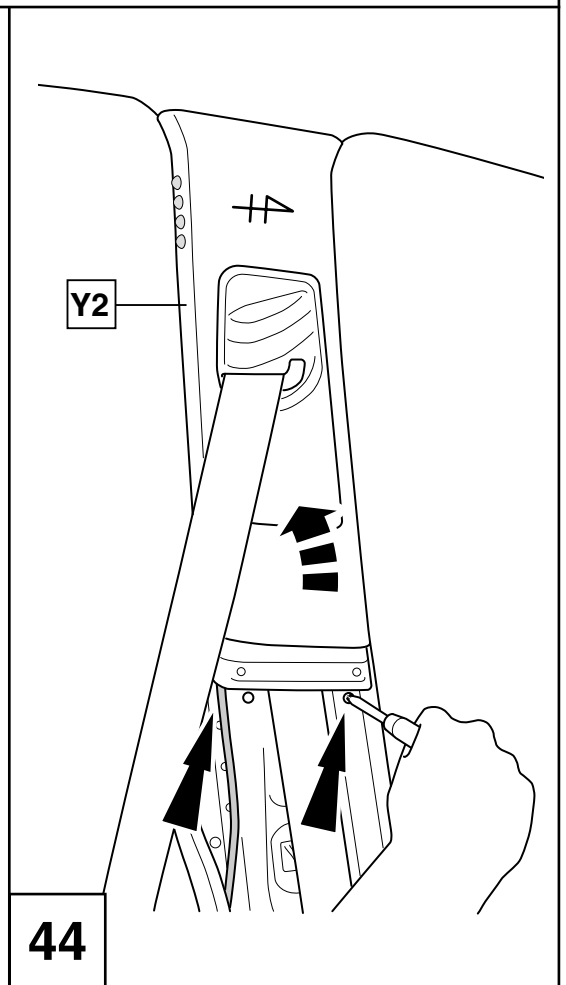
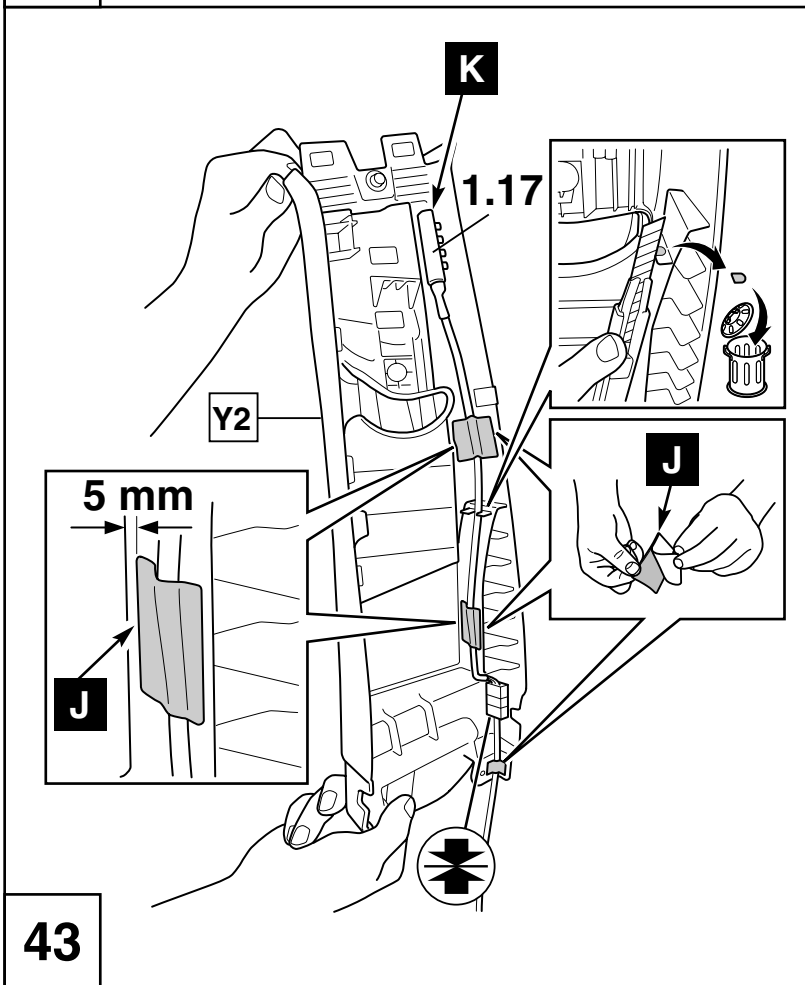
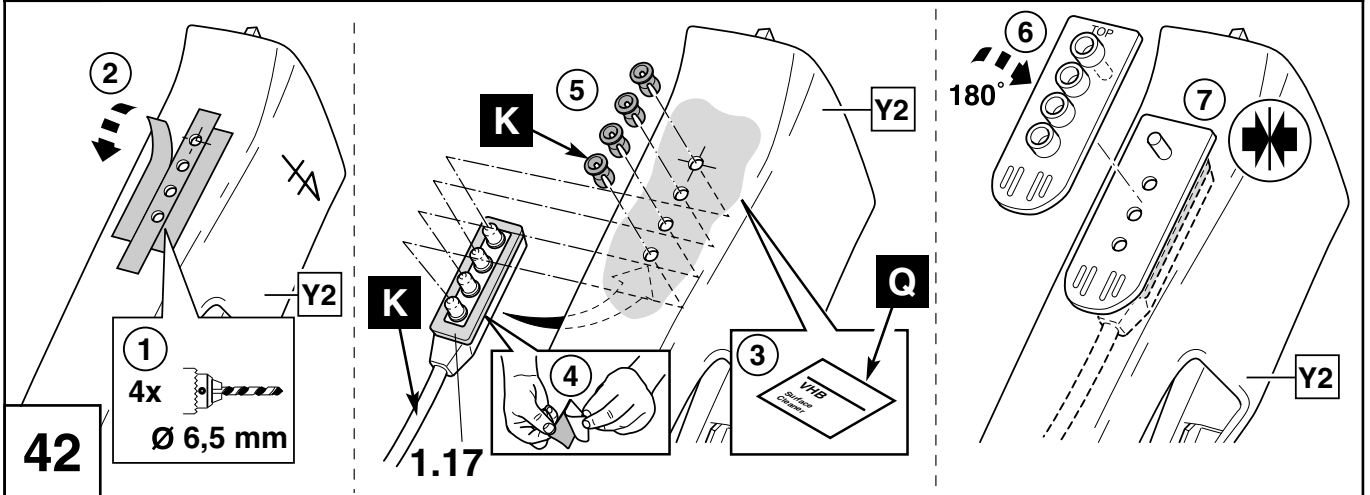
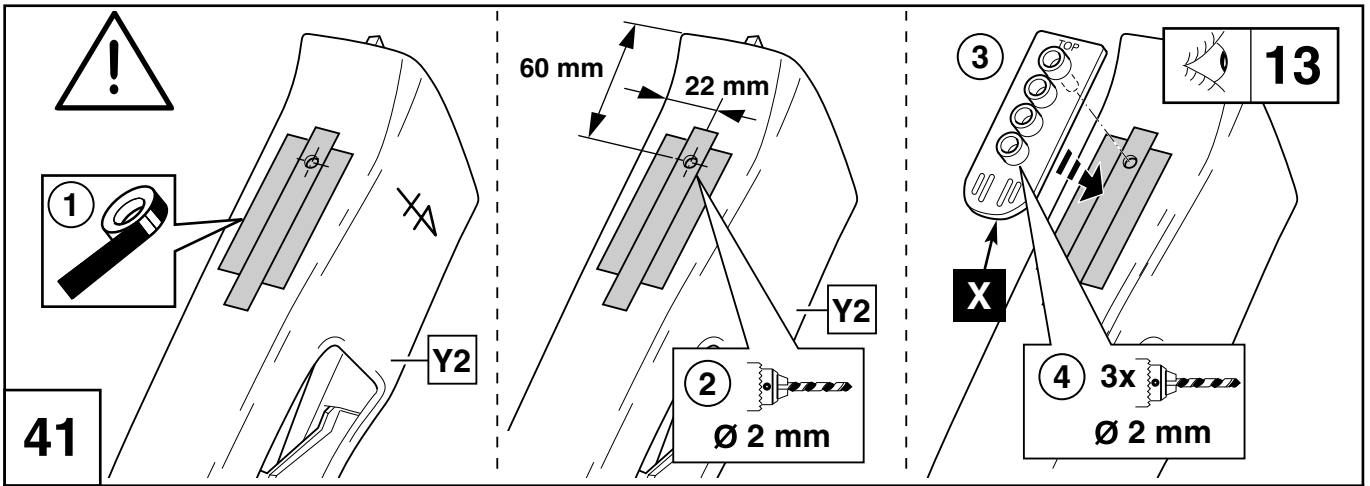

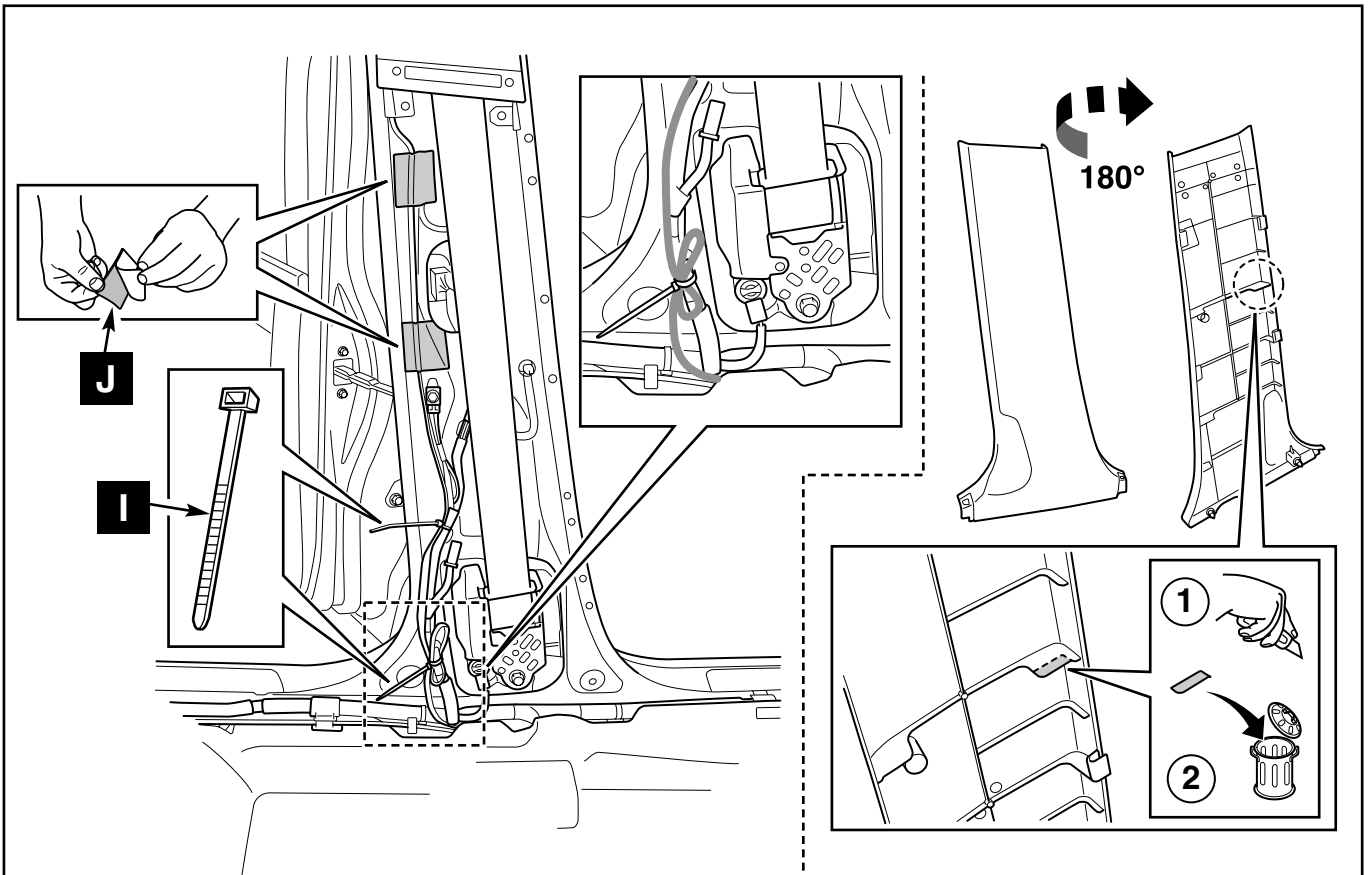

45

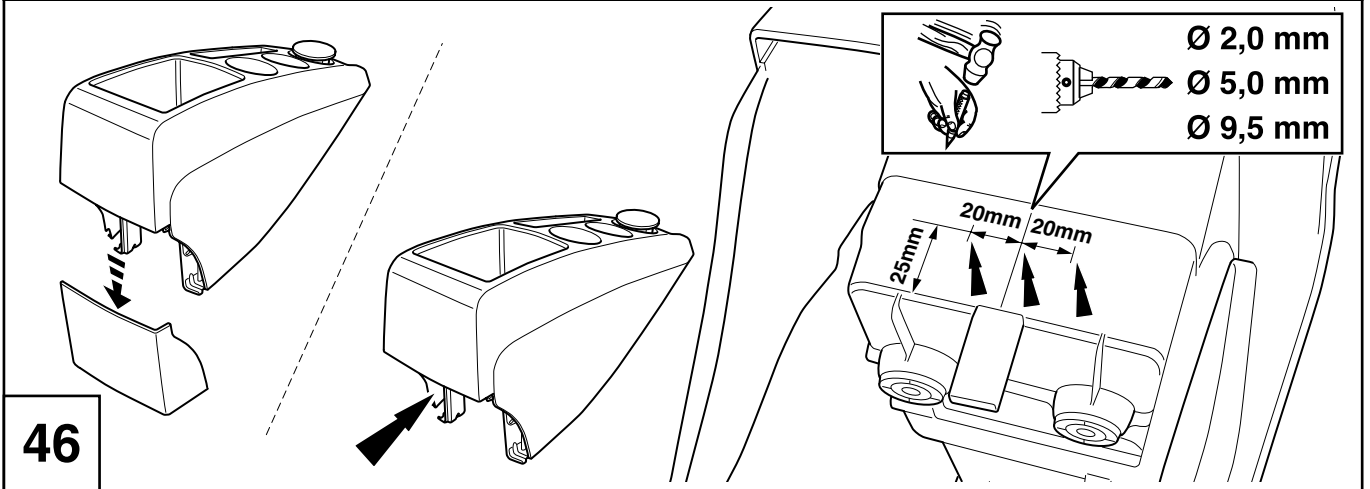

46

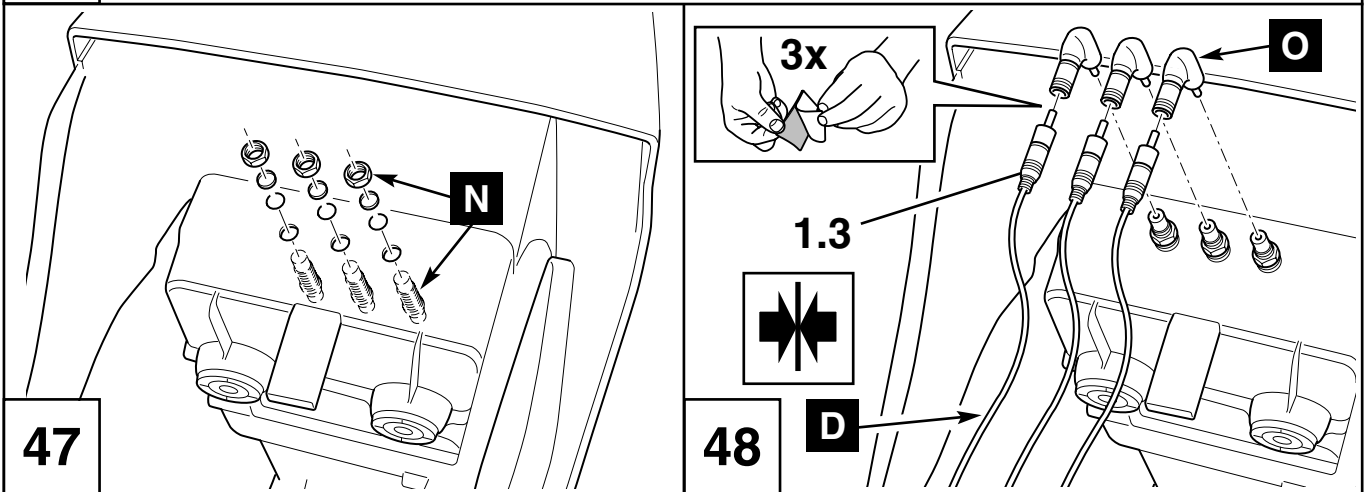

47

48

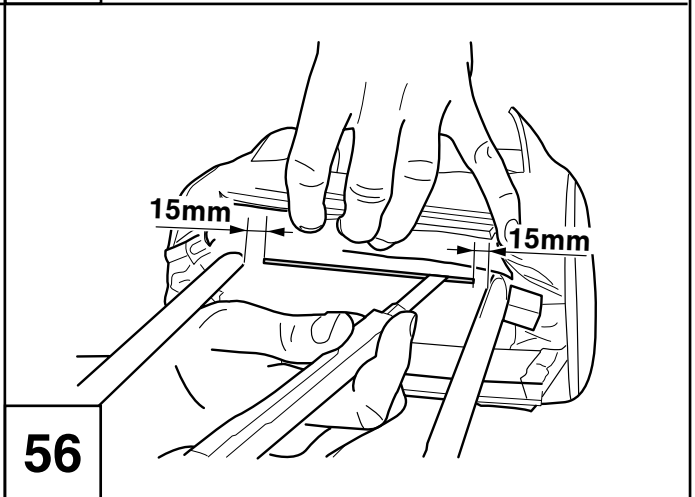
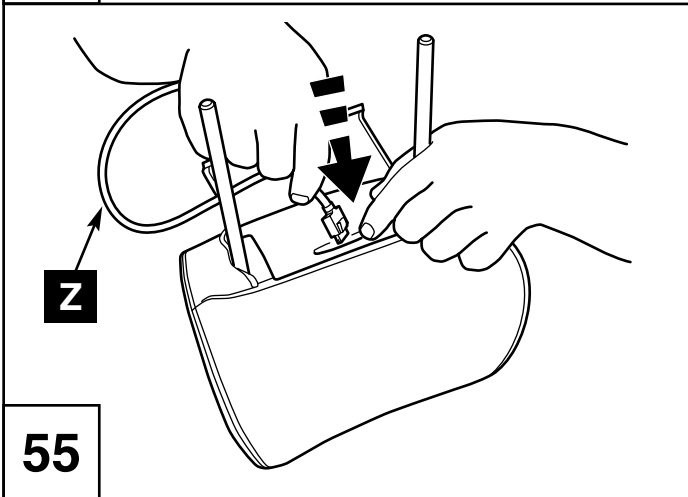
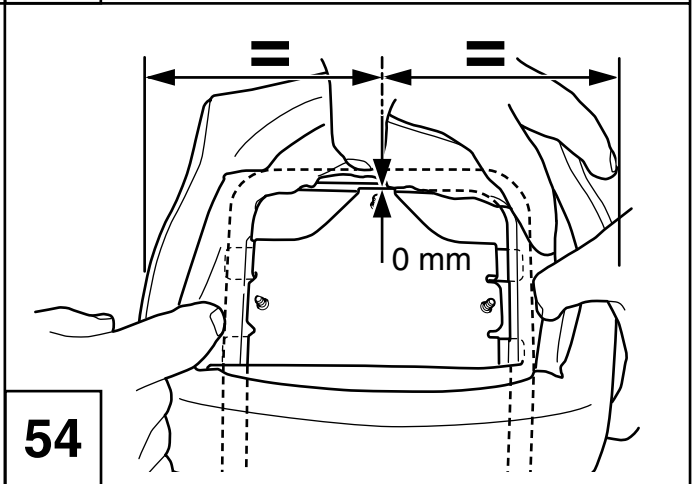
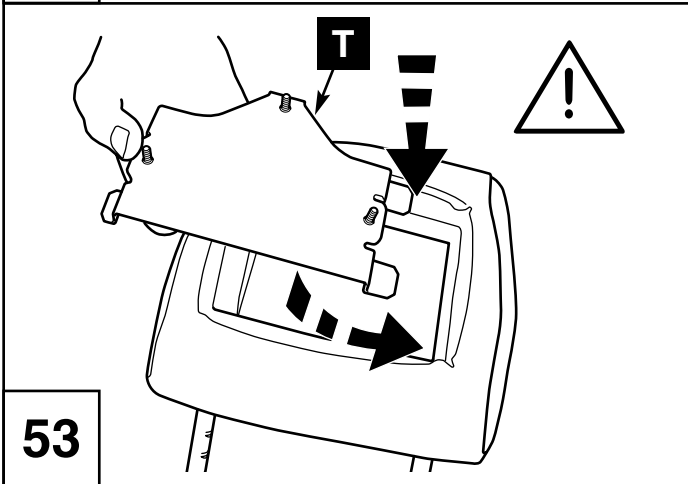
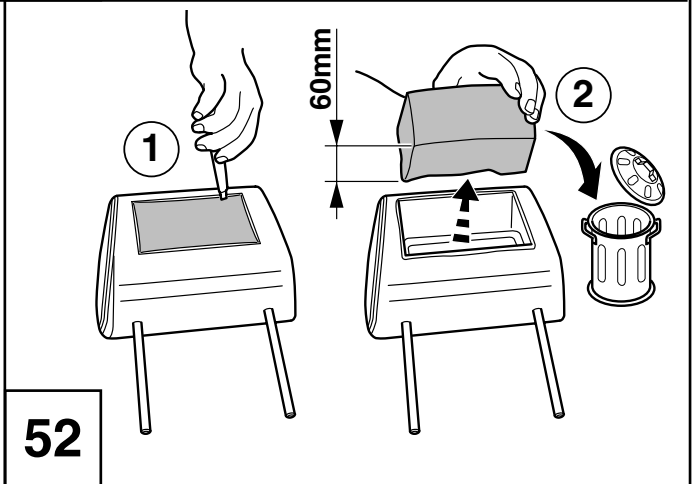
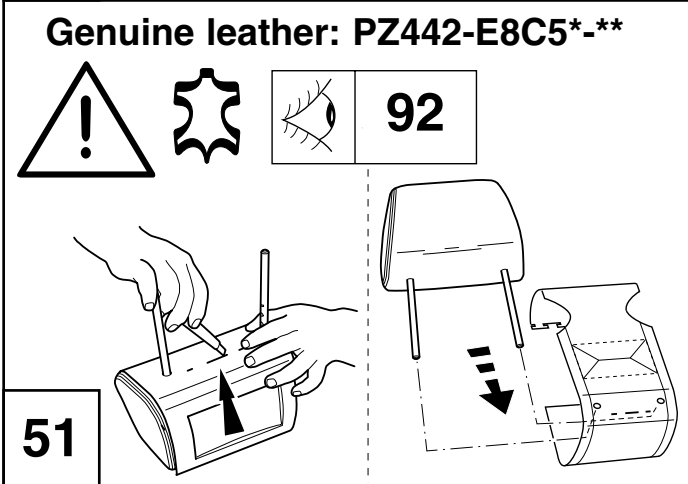
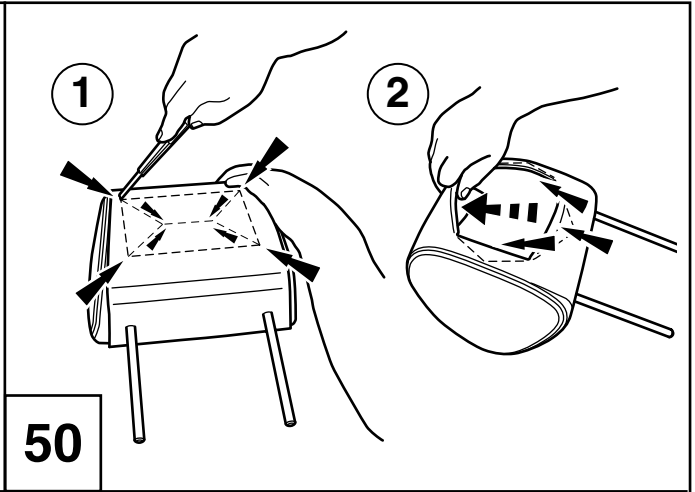
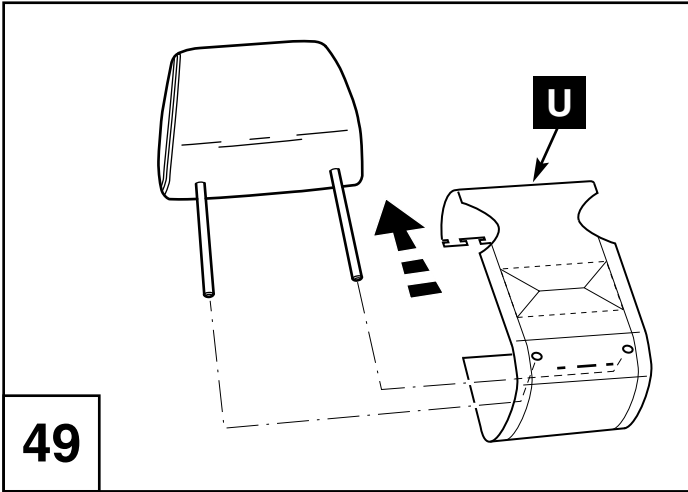

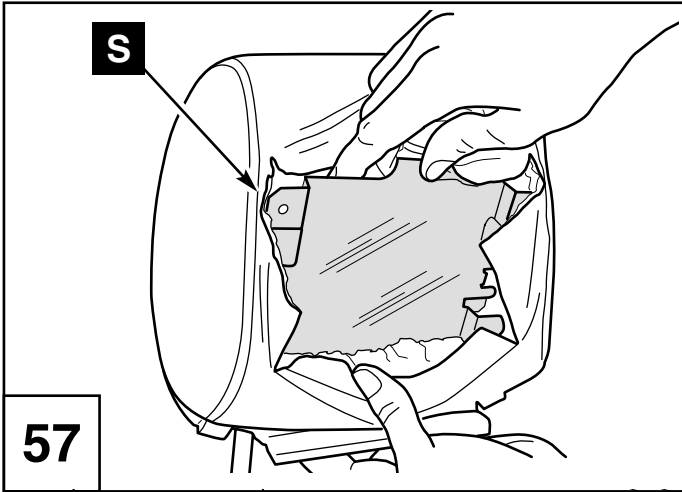

57

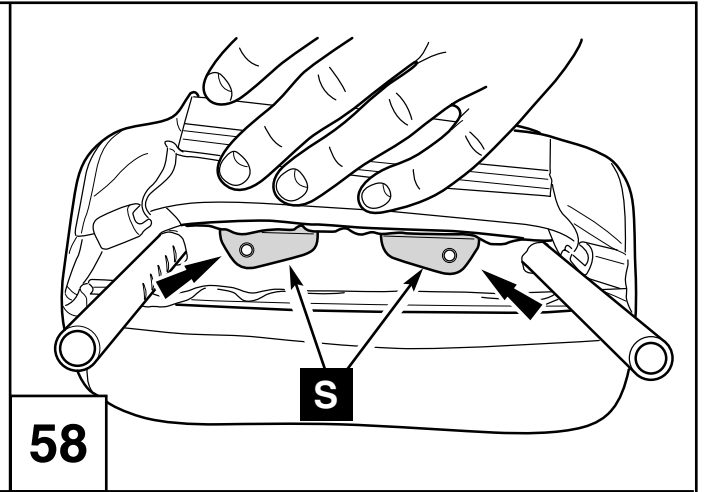

58

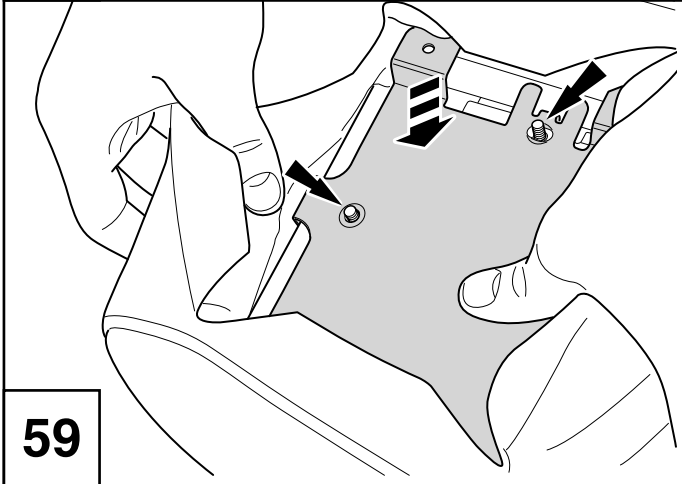

59

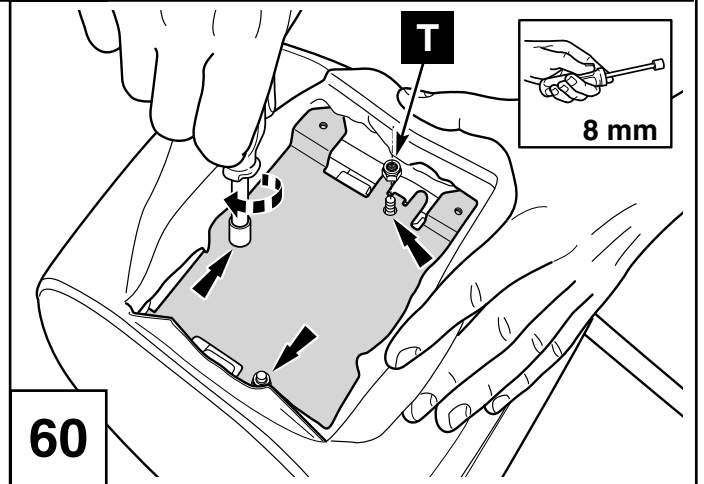

60

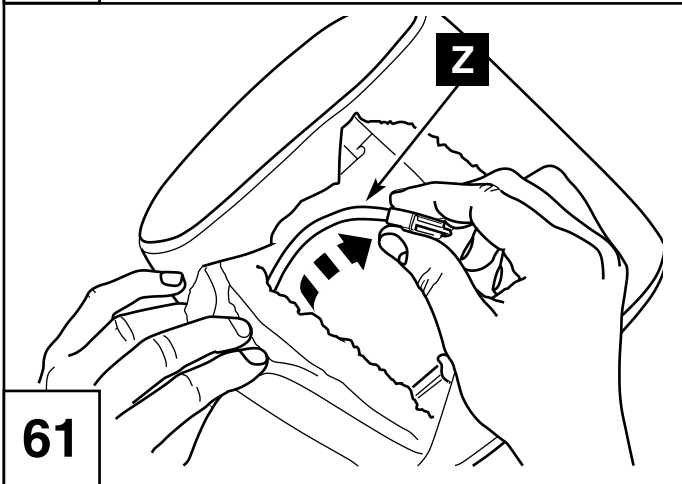

61

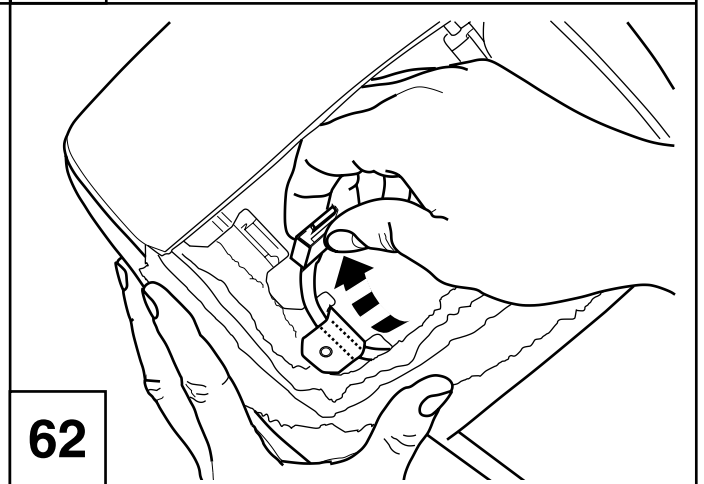

62

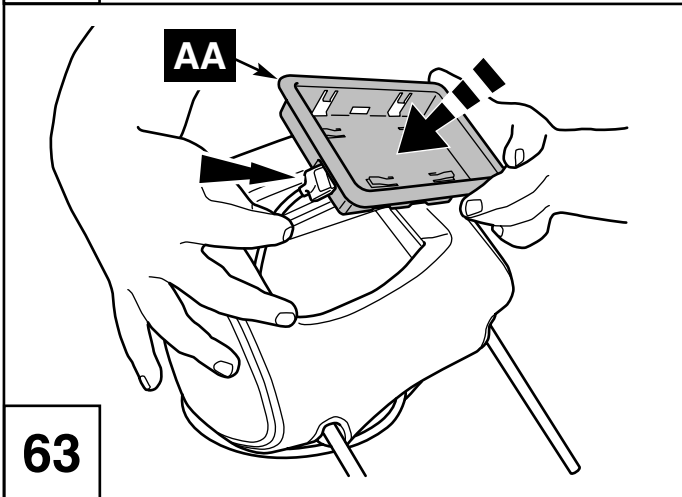

63

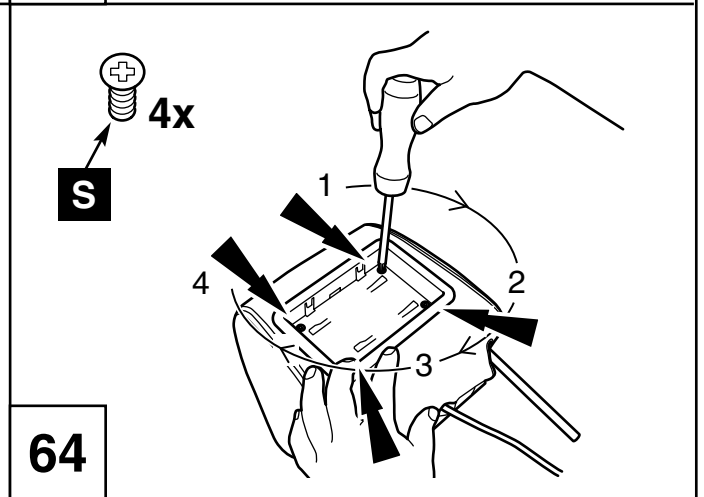

64

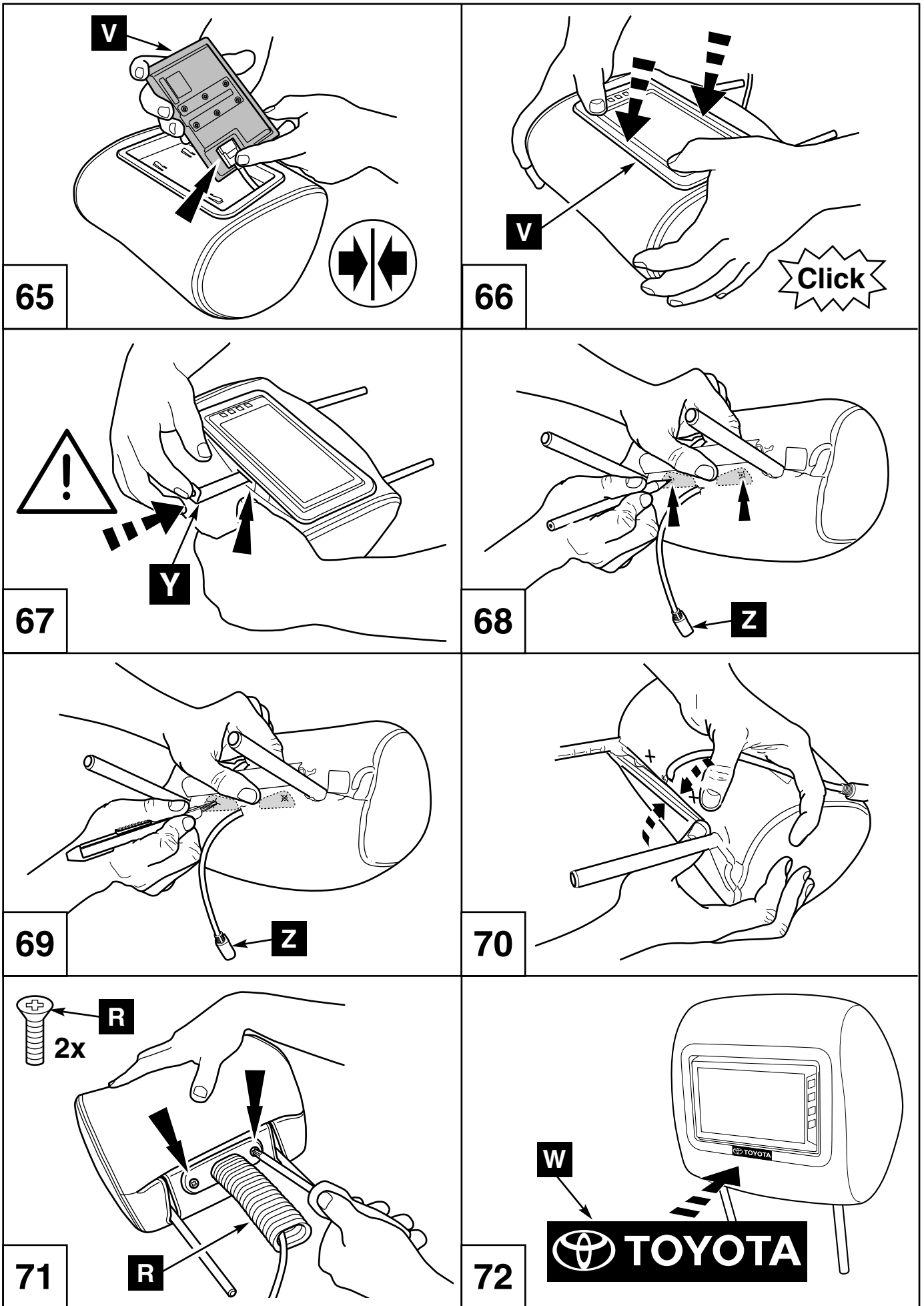

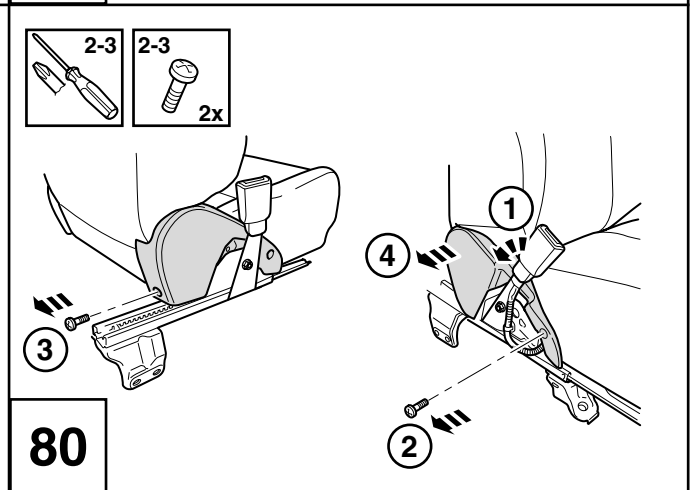
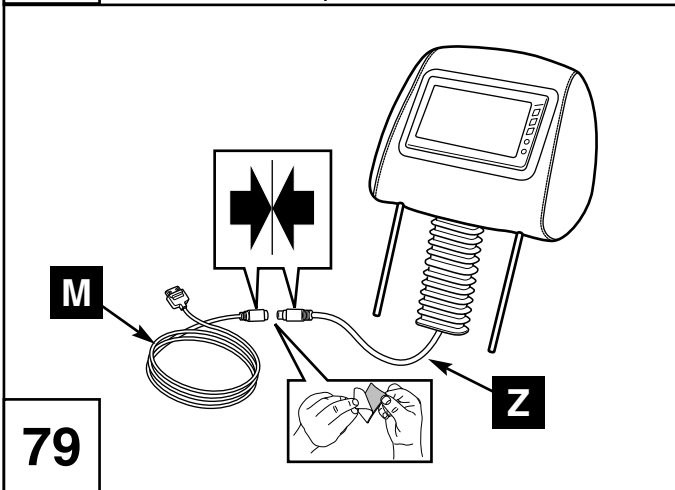
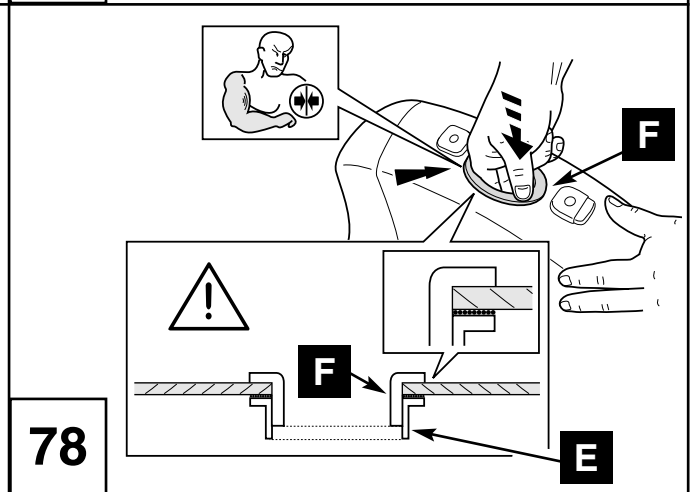
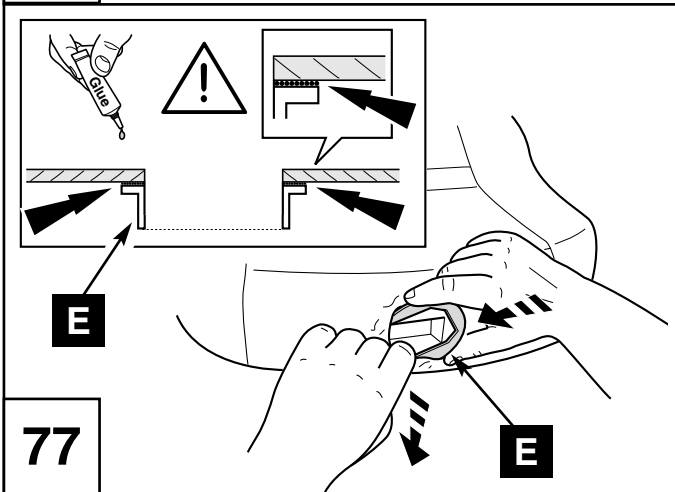
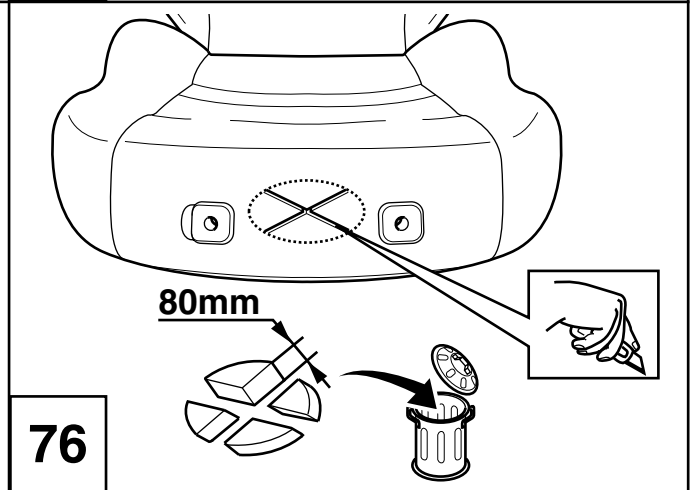
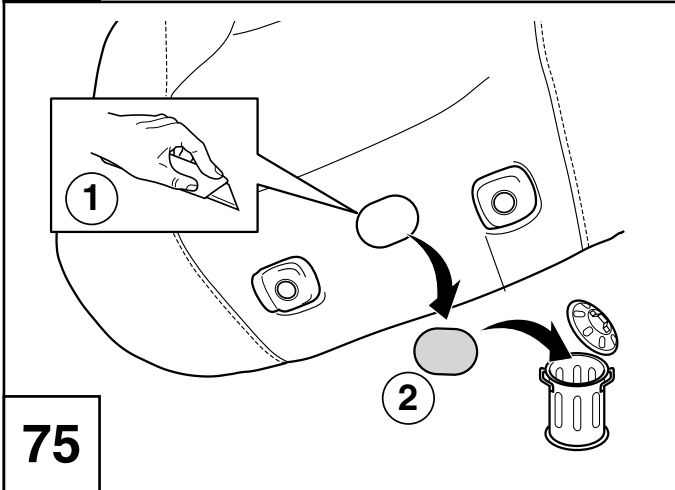
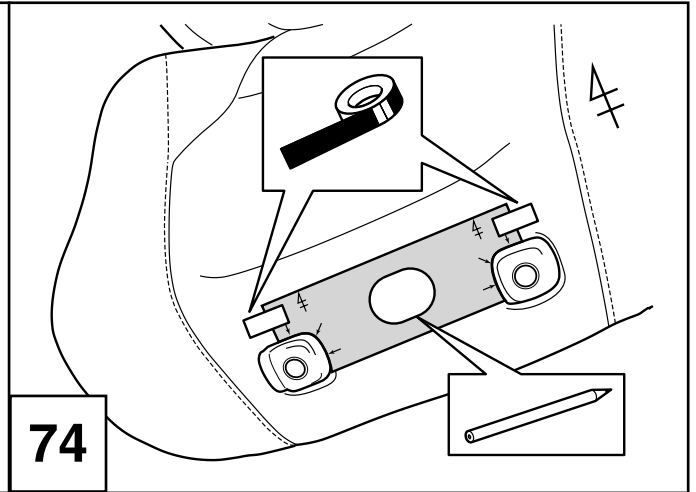
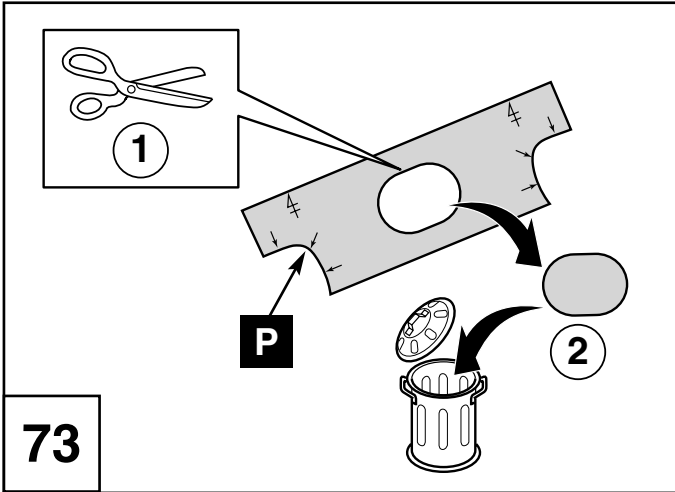

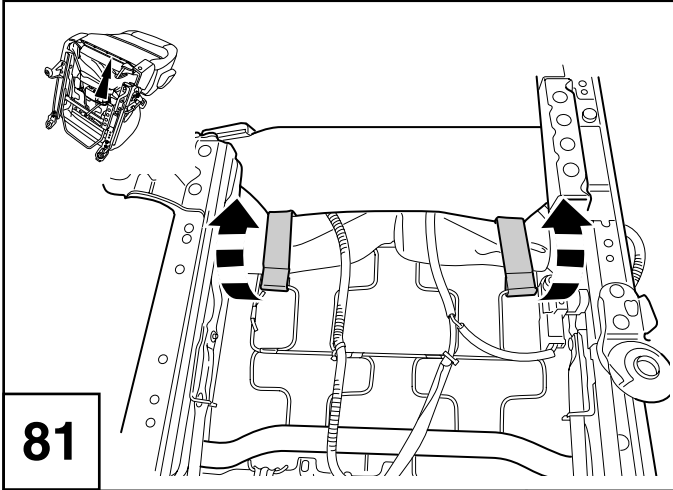

81

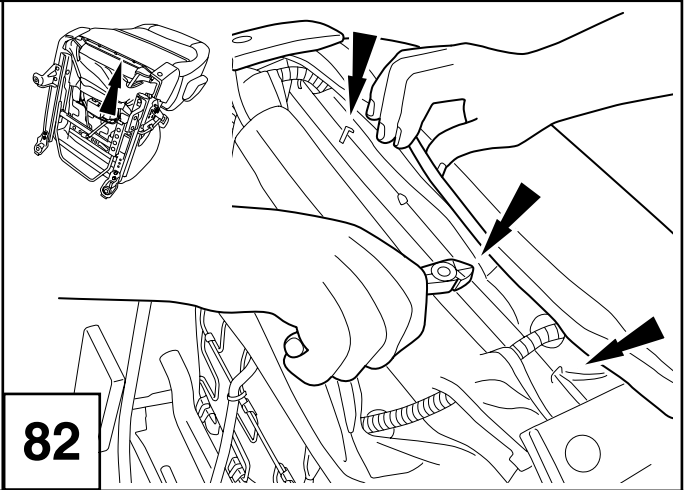

82

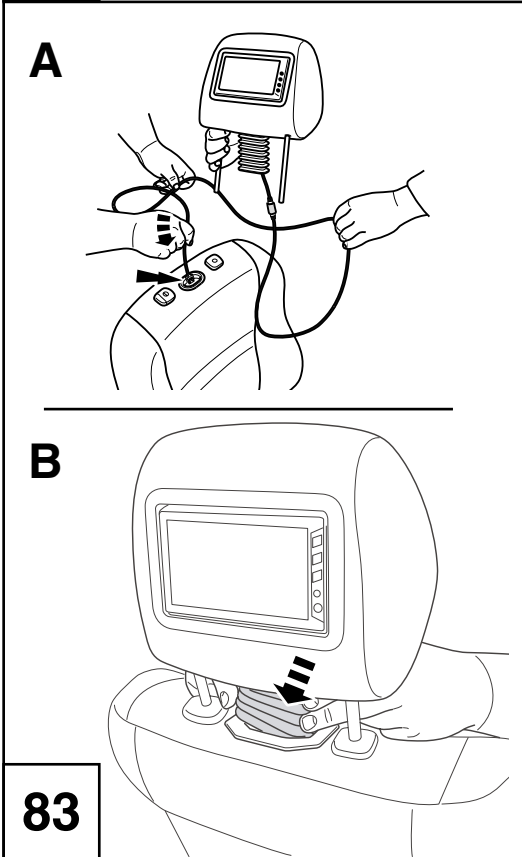

83

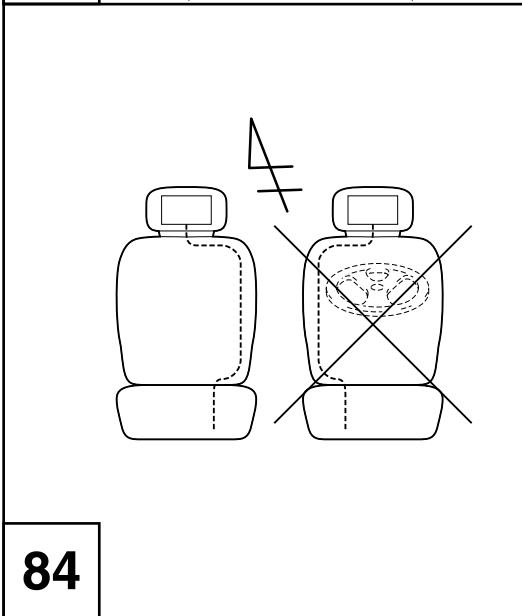
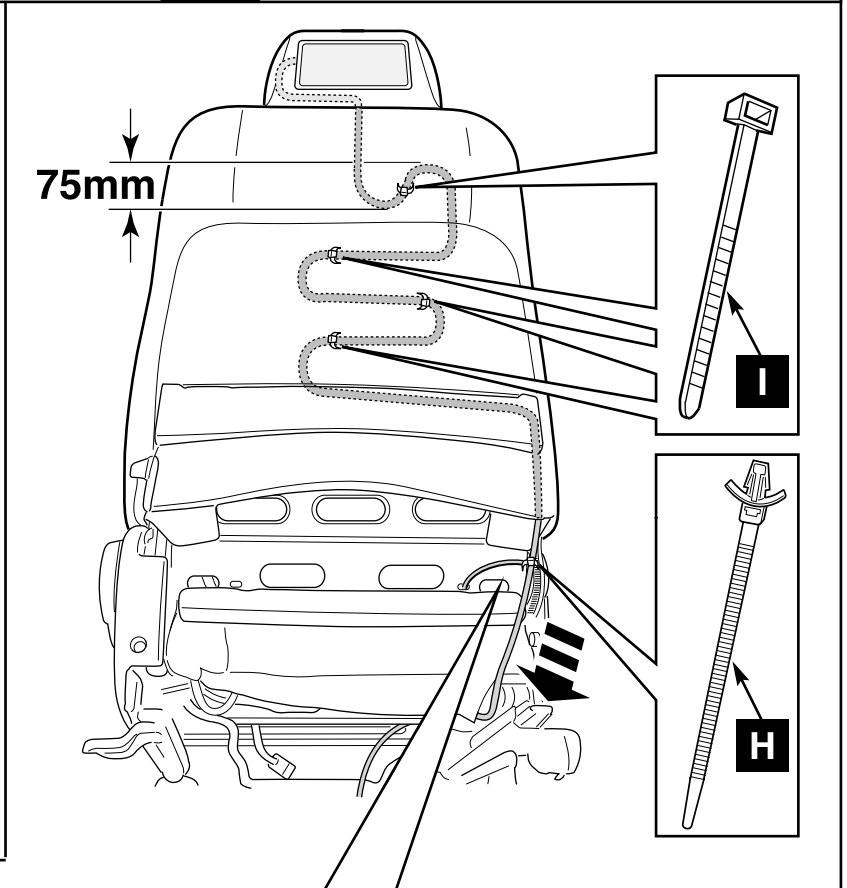

84

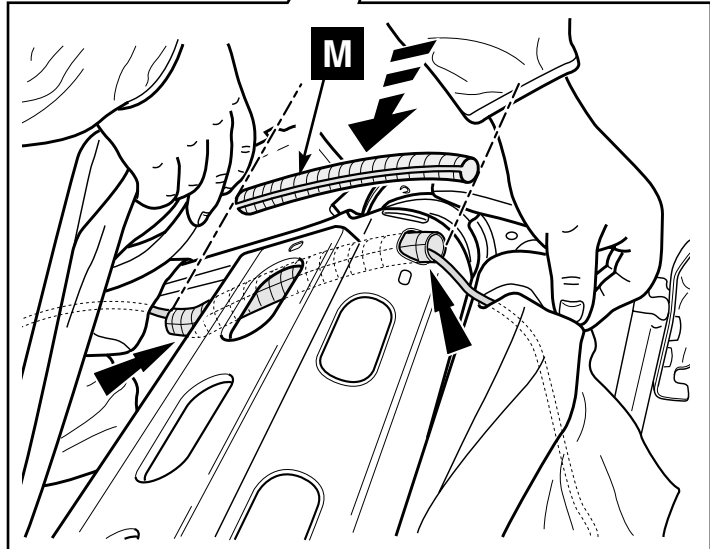

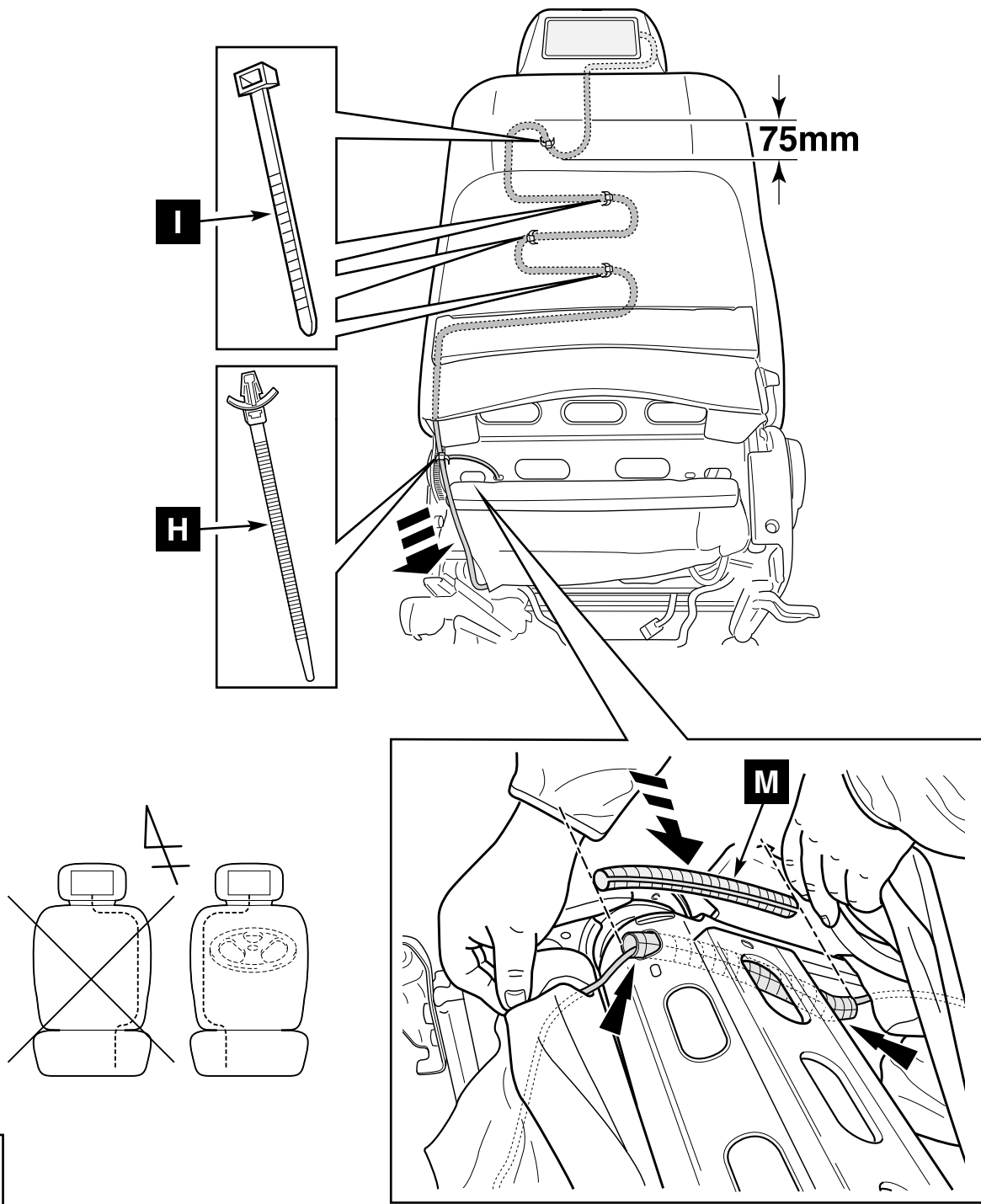

85

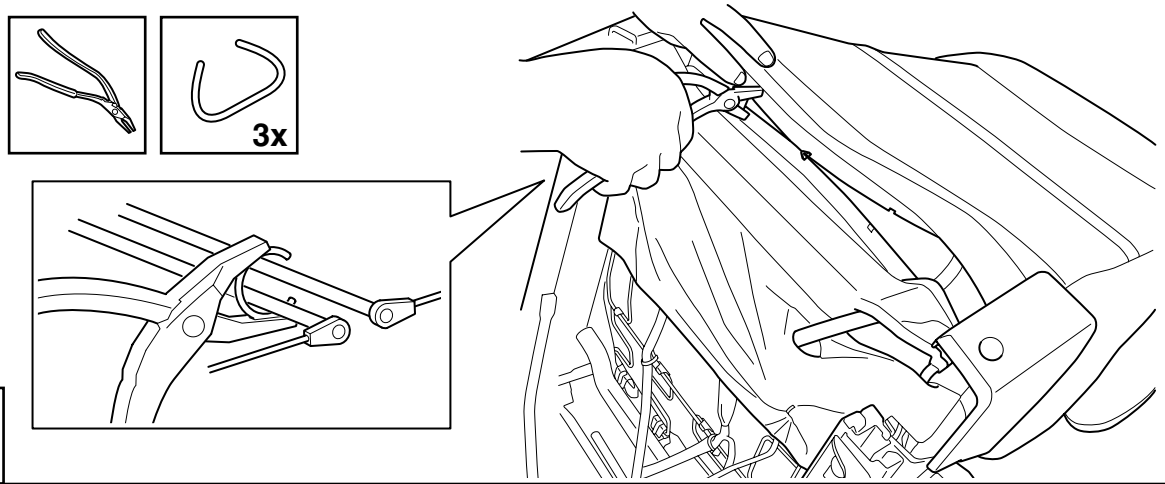

86

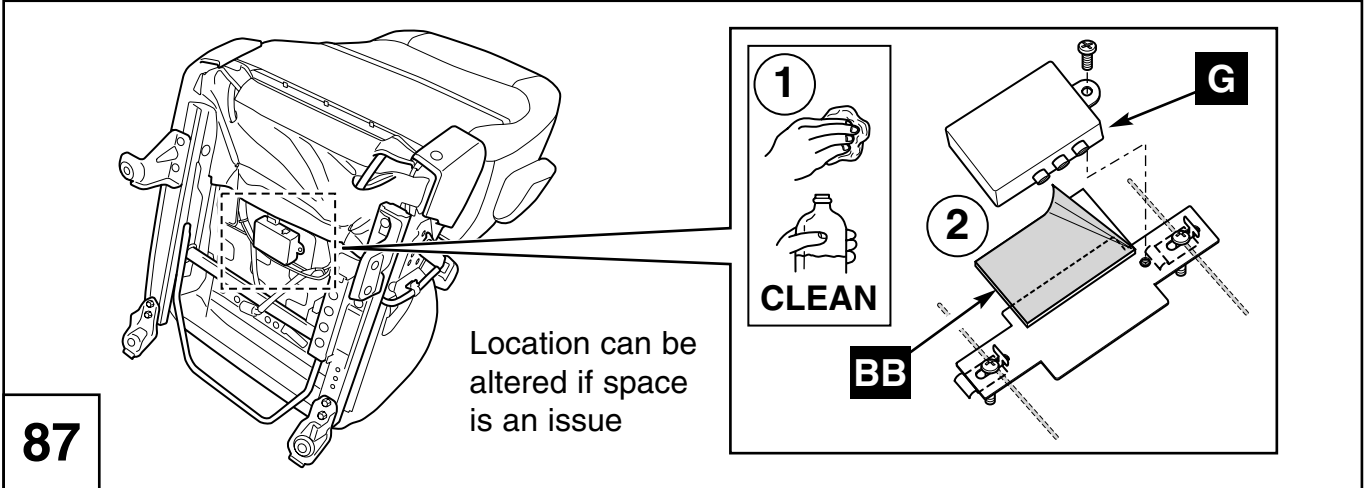

87

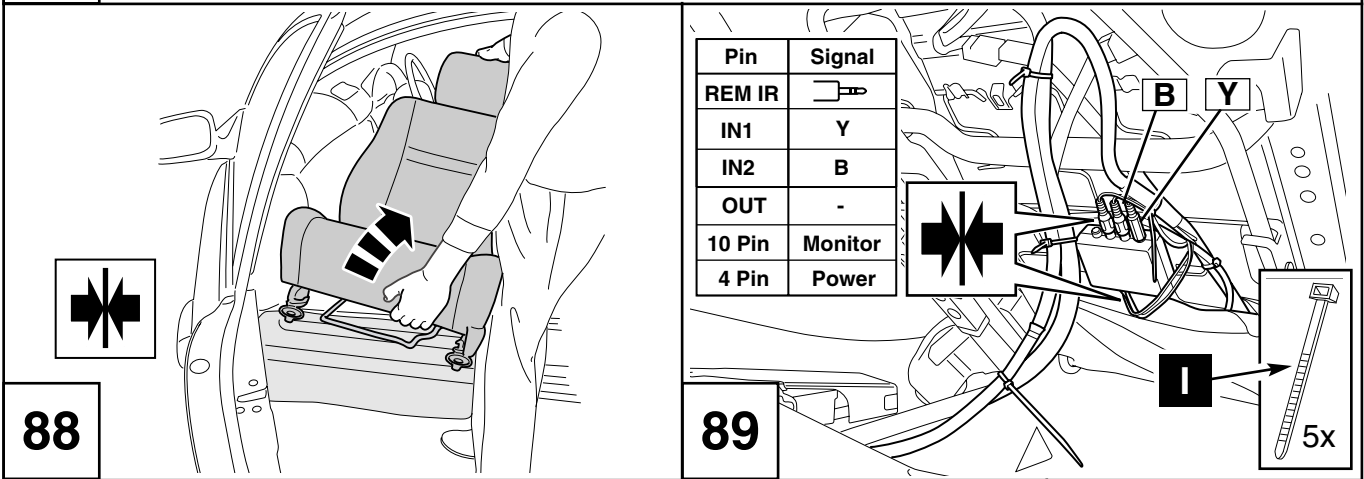

88

89

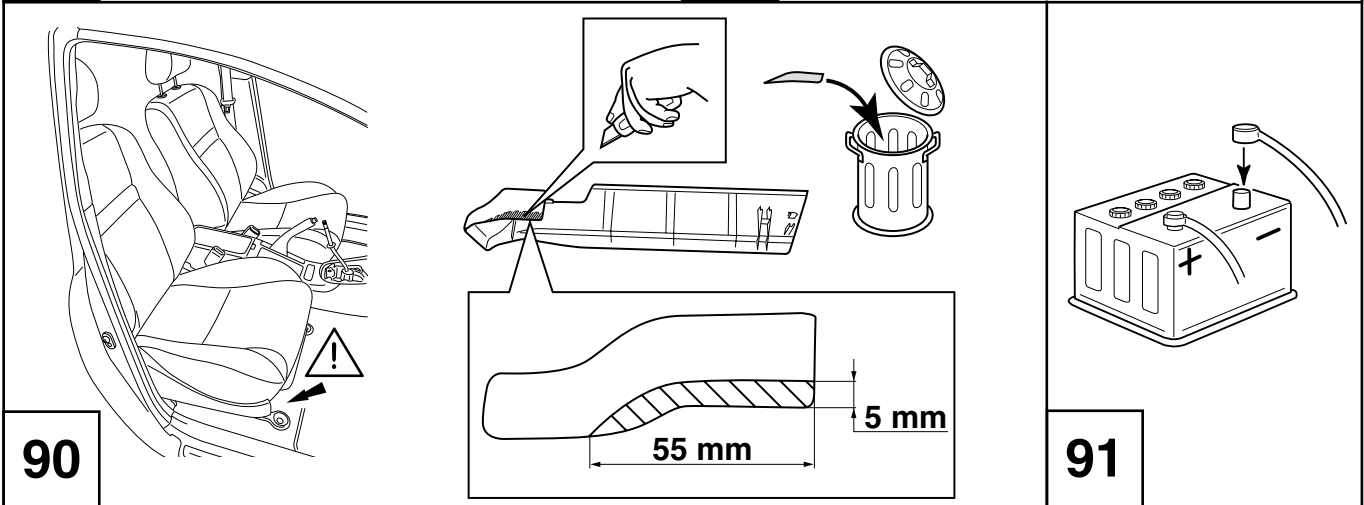

90

91

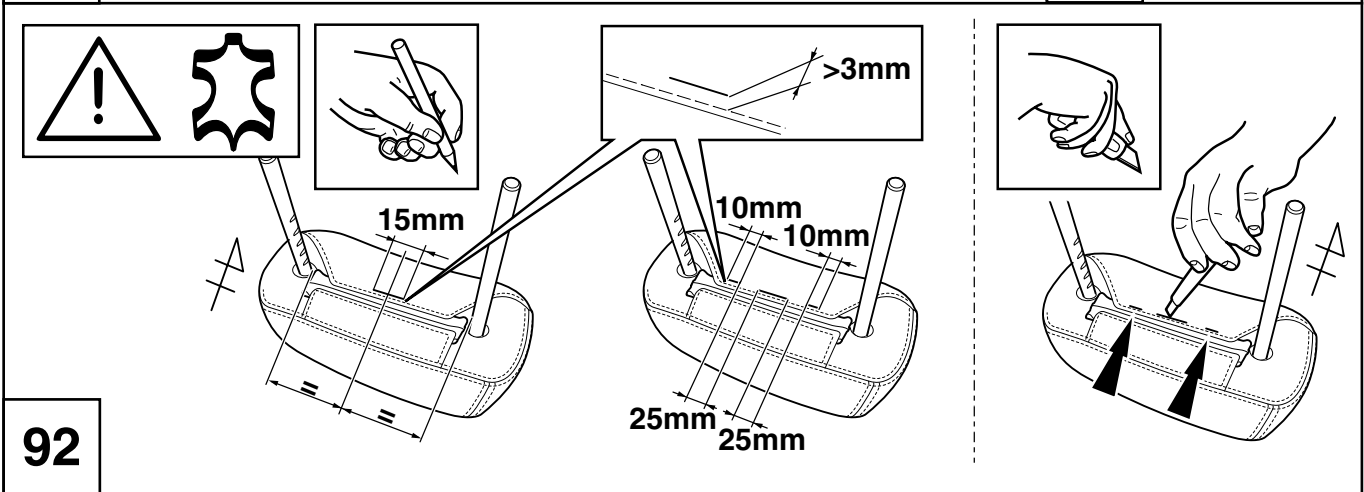

92

GB

After installation and function check, be certain to re-fit panels and connectors correctly and tighten all bolts to the specified torque settings in line with the Repair Manual.

D

Stellen Sie sicher, dass Sie nach der Installation und der Funktionsüberprüfung alle Abdeckungen und Anschlüsse wieder korrekt anbringen und alle Schrauben auf das im Reparaturhandbuch angegebene Drehmoment festziehen.

E

Luego de la instalación y la verificación del funcionamiento, asegúrese de montar los paneles y conectores correctamente y de ajustar todos los tornillos a los torques especificados según lo indicado en el manual de reparación.

F

Après installation et vérification du fonctionnement, assurez-vous de bien remettre les panneaux et les connecteurs et de fixer les boulons selon les instructions de serrage spécifiques, conformément au manuel de réparation.

I

Dopo aver eseguito l'installazione e aver verificato il funzionamento del dispositivo, rimontare correttamente i pannelli e i connettori, quindi avvitare tutti i bulloni rispettando la coppia specificata nel Manuale delle riparazioni.

P

Após a instalação e verificação do funcionamento, certifique-se de que ajusta correctamente os painéis e conectores e que aperta todos os parafusos de acordo com as definições de esforço de torção especificadas no manual de reparações.

NL

Zorg dat u, na de installatie en functionele controle, de panelen weer bevestigd en de connectors juist aanbrengt. Haal de bouten aan met het voorgeschreven aanhaalmoment (raadpleeg de reparatiehandleiding).

DK

Efter montering og funktionskontrol skal du sørge for at fastgøre paneler og stik rigtigt igen og stramme alle bolte i overensstemmelse med momentindstillingerne i reparationsvejledningen.

N

Etter at du er ferdig med installeringen og har utført en funksjonskontroll, må du påse at alle paneler og tilkoblingsselementer festes igjen på korrekt måte, og at alle skruer strammes i henhold til dreiemomentene som er beskrevet i reparasjonshåndboken.

S

Efter installations- och funktionskontrollen sätter du tillbaka höljet och kontakterna ordentligt och drar åt alla skruvar till angivna vridmomentsinställningar, i enlighet med reparationshandboken.

FIN

Asennuksen ja toiminnan tarkistamisen jälkeen kiinnitä paneelit ja liittimet takaisin paikoilleen ja kiristä pultit määrättyyn tiukkuuteen korjausoppaan mukaisesti.

CZ

Po instalaci a kontrole funkčnosti je třeba opět správně nasadit panely a připojit konektory. Dále je také nutné řádně utáhnout všechny šrouby podle nastavení uvedeného v servisní příručce.

H

A telepítést és a funkcionális ellenőrzést követően rögzítse újra a paneleket és csatlakozókat, valamint húzzon minden rögzítőcsavart a Javitási útmutatóban meghatározott erősségi fokozatig.

PL

Po zakończeniu montażu i sprawdzeniu funkcji należy poprawnie zamocować panele i złącza oraz dokręcić wszystkie śruby zgodnie z ustawieniami momentu obrotowego podanymi w podręczniku napraw.

GR

Μετά την εγκατάσταση και τον έλεγχο λειτουργίας βεβαιωθείτε πως έχετε επαναποθετήσει τους πίνακες και τους συνδέσμους σωστά και πως έχετε σφίξει όλες τις βίδες προς τη συγκεκριμένη ροπή σύμφωνα με τις οδηγίες του χειριδίου επιδιορθώσεως.



CHECK SIZE

Print 100%
Check with Rulers
before use.

