



TOYOTA

ALWAYS A
BETTER WAY

Aygo

Roof spoiler

Installation Instructions

Model year: 2005
Vehicle code: **B10*-A****W
Part number: PZ402-90470-AB

Manual reference number: AIM 000 234-1

Revision record

Rev. No.	Date	Page	Picture	Update	New	Deleted steps
1	22/09/2014	2	tools	x		
		4	11, 14-15	x		

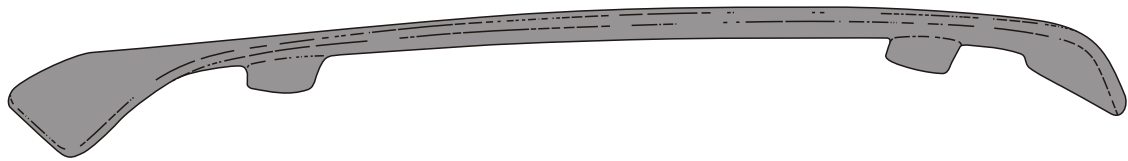

A

1x

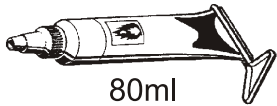

80ml

1x

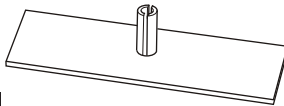

C

2x



M6×20

D

2x



M6

E

2x

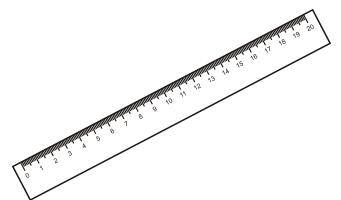
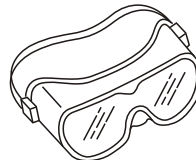
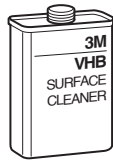
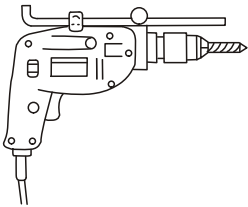

P80

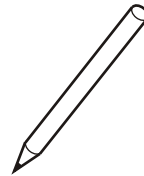
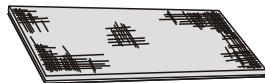

Ø3, Ø5, Ø8, Ø11mm

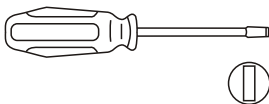

ANTI RUST

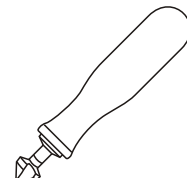
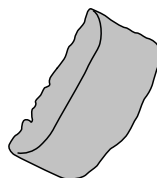
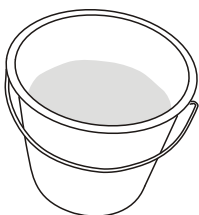

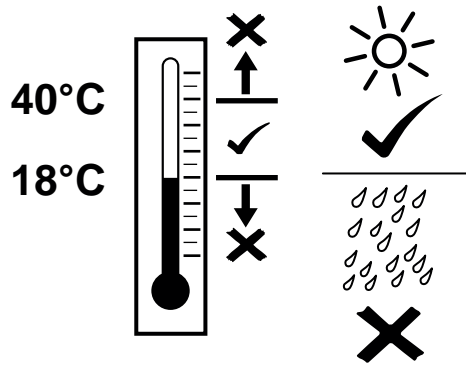

1

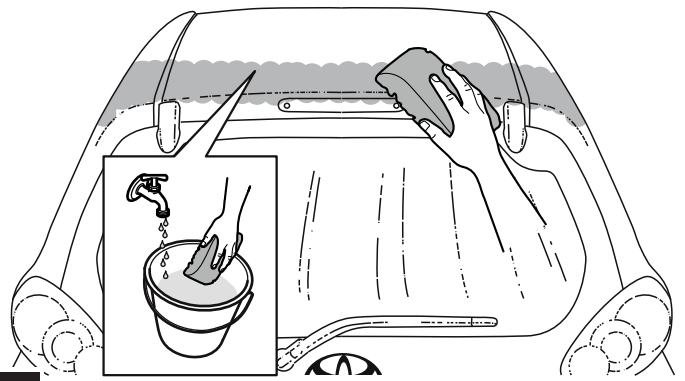

2

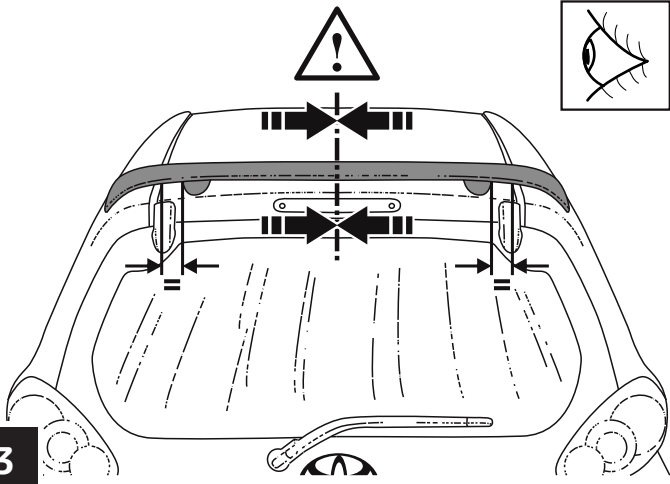

3

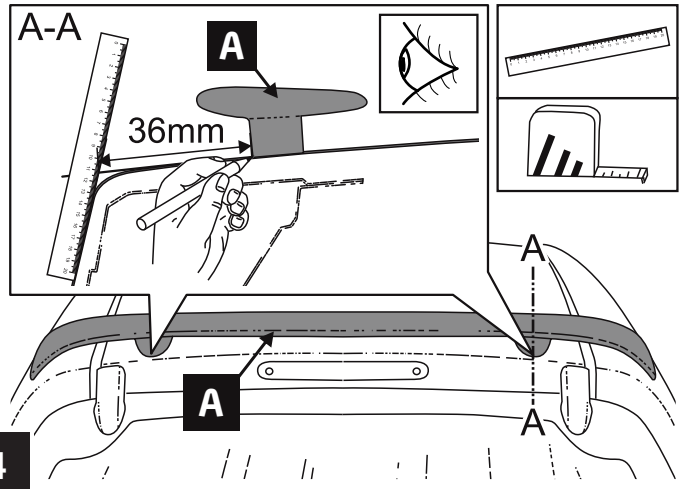

4

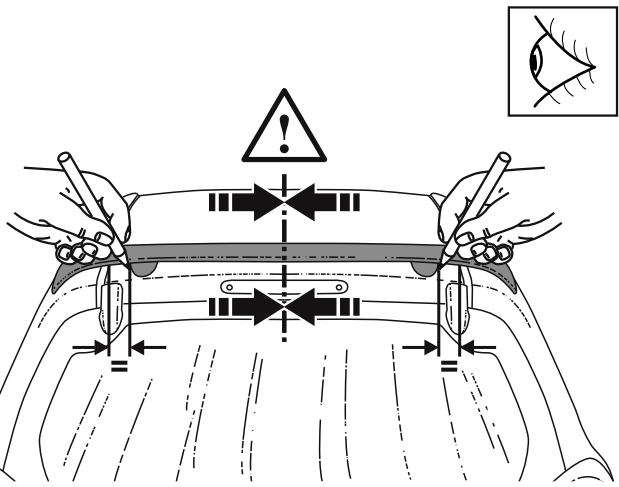

5

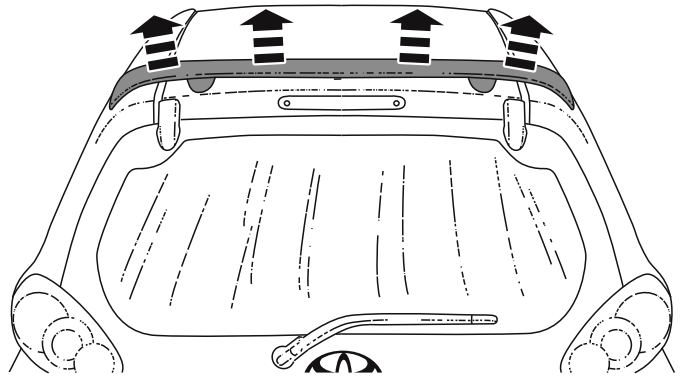

6

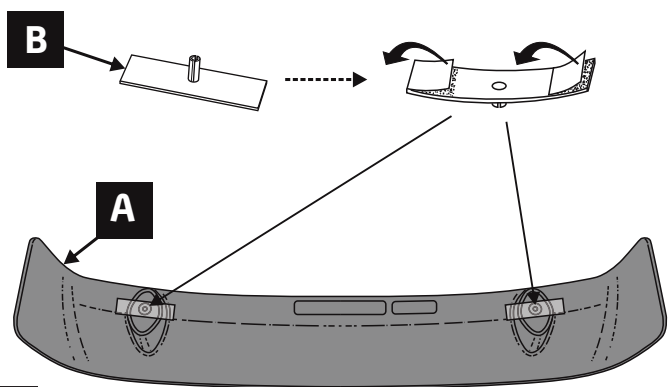

7

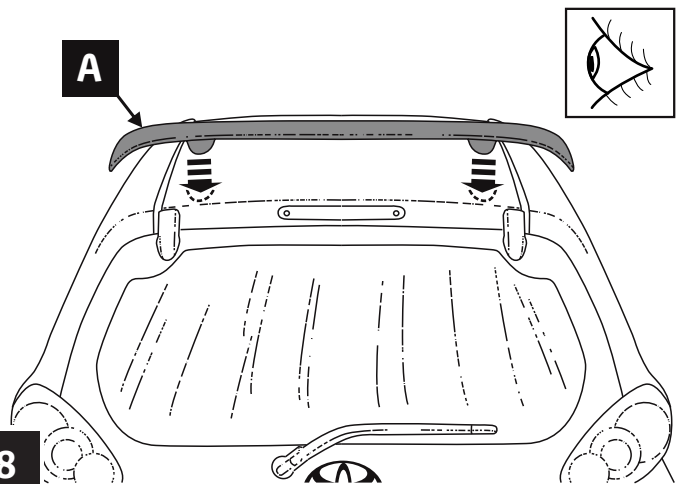

8

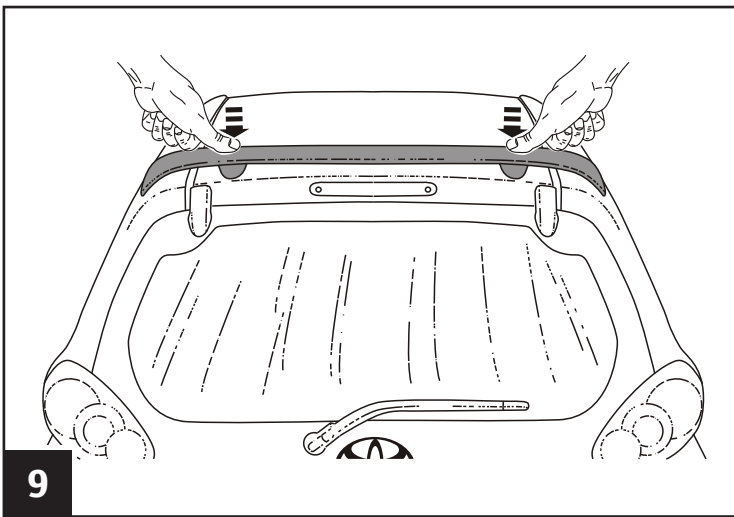

9

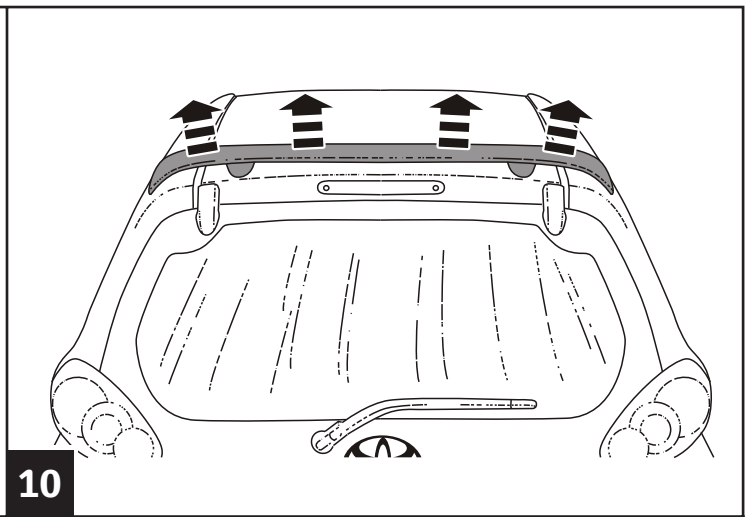

10

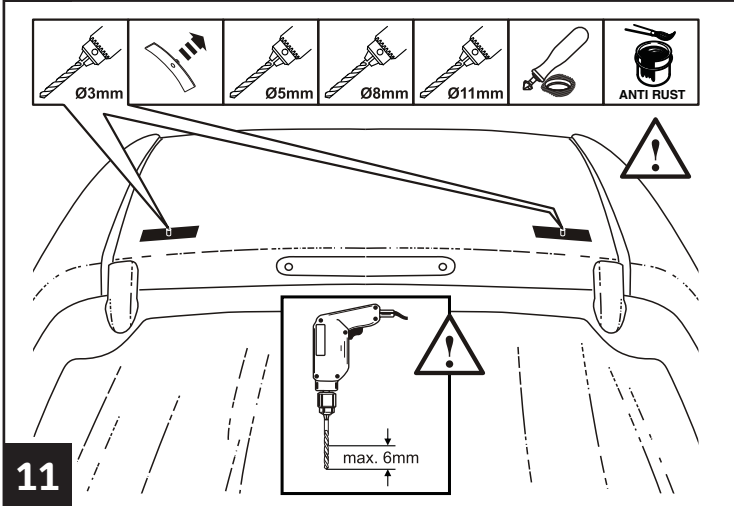

11

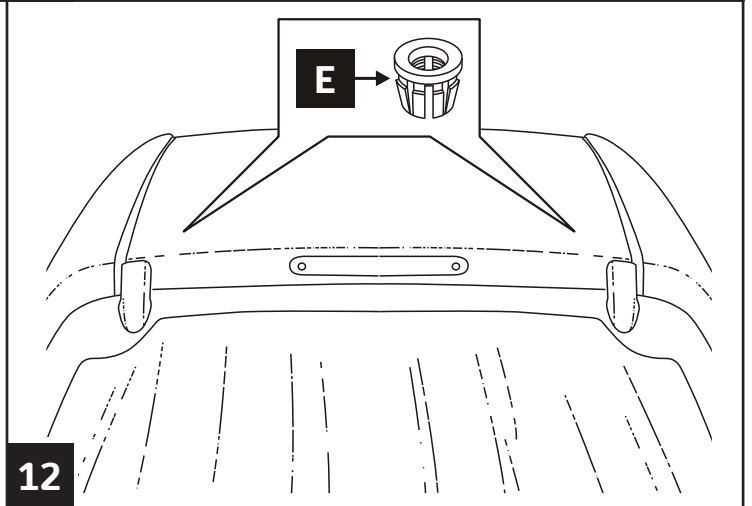

12

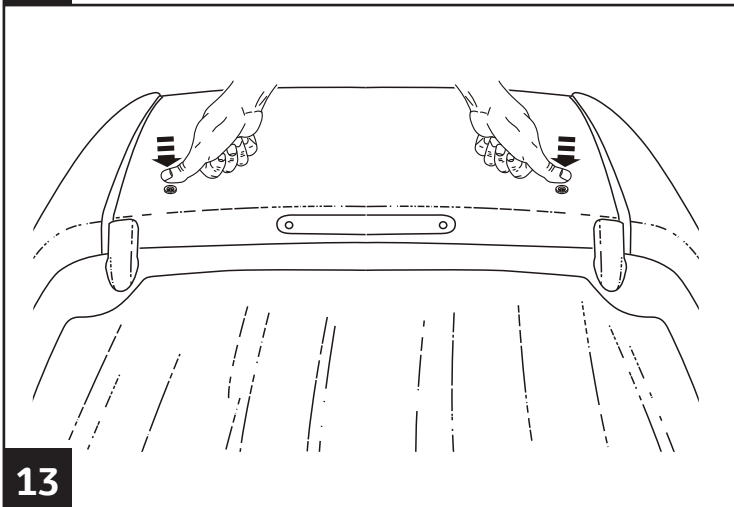

13

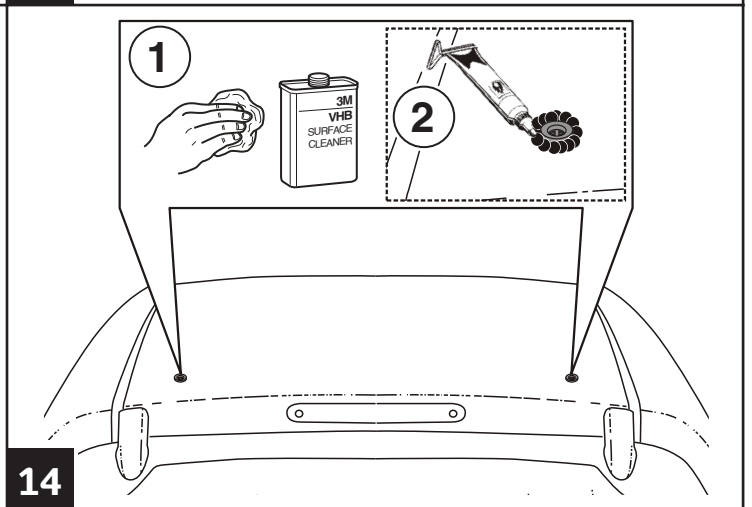

14

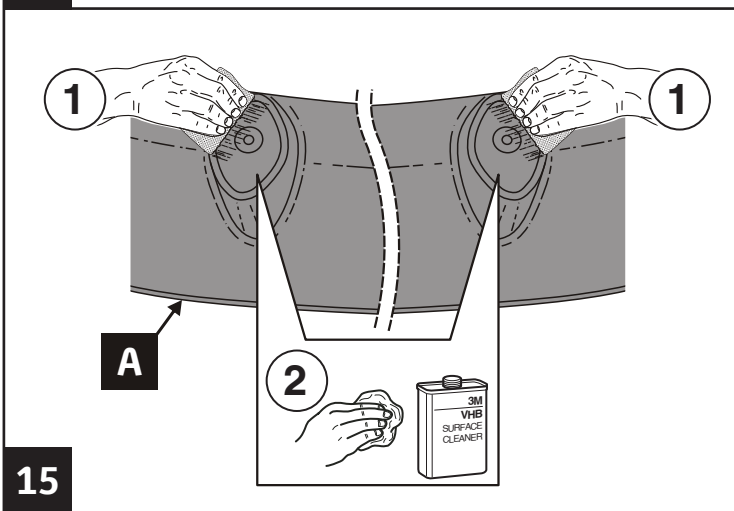

15

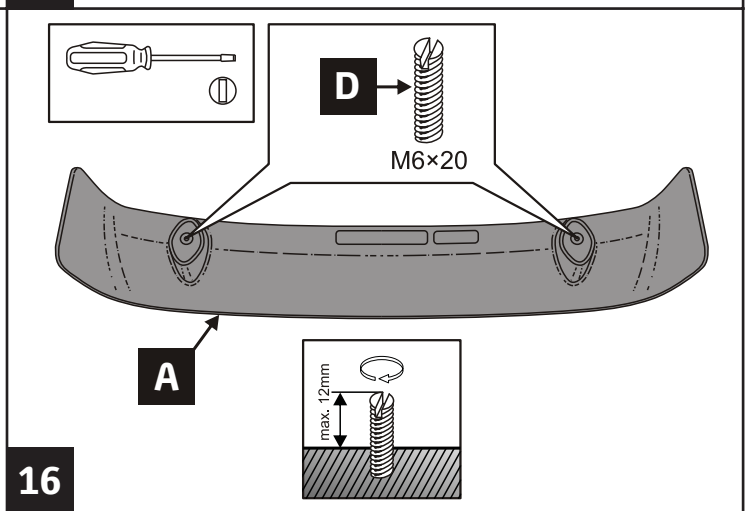

16

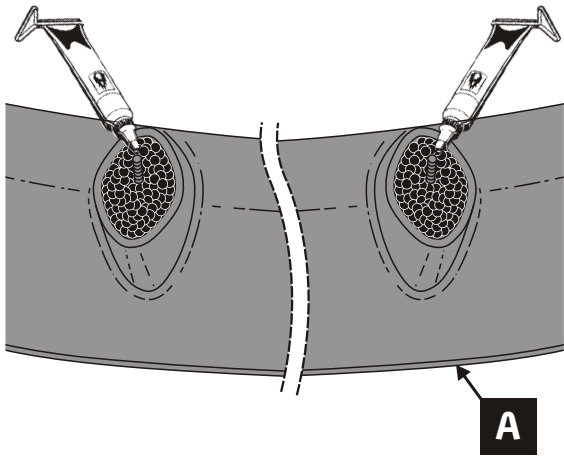

17

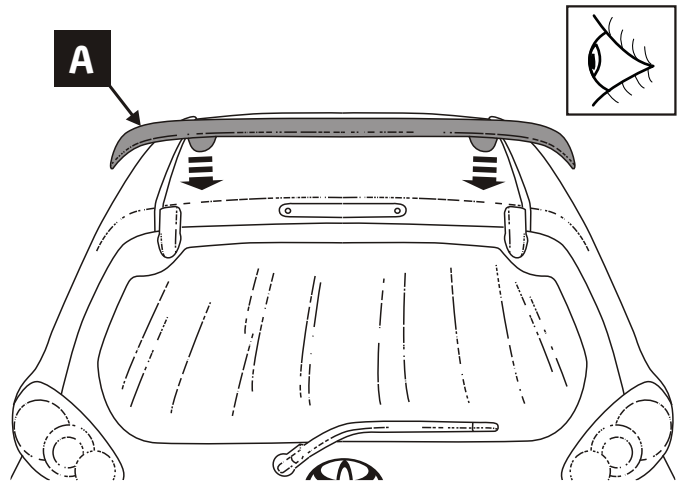

18

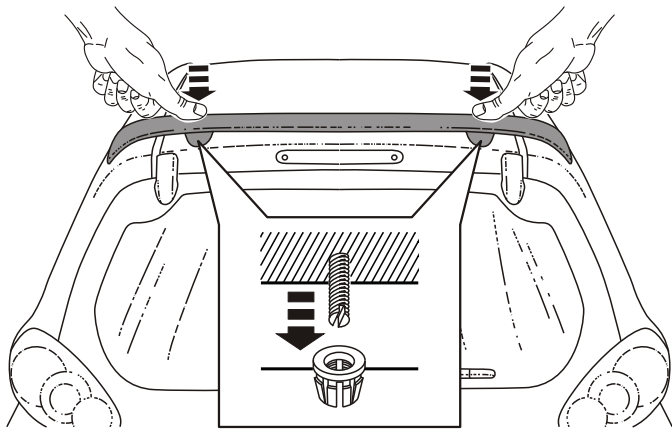

19

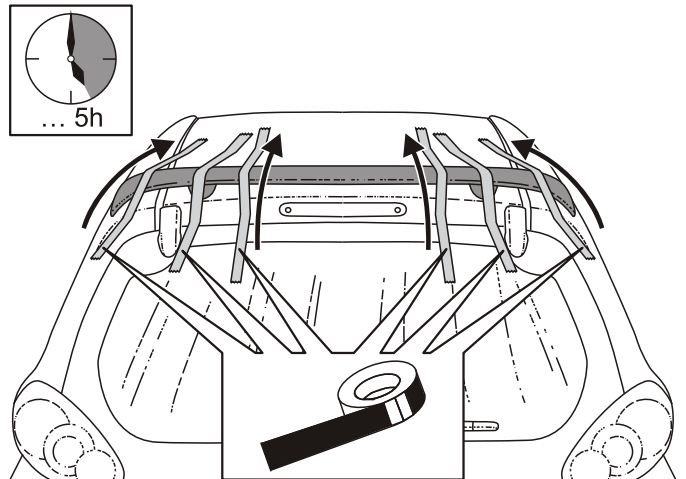

20

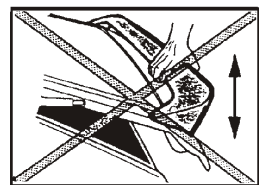
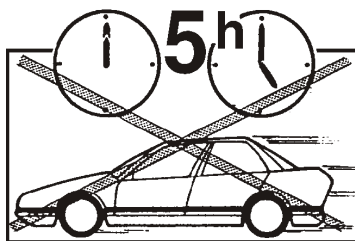

21

**ATTENTION
ACHTUNG
ATTENTION**



**ATTENCION
ATTENTIE
ATTENZIONE**

FR

Nous attirons votre attention sur le fait que toute réclamation ou demande en dommage et intérêt ne pourrait être formulée que tant que le montage aura été fait suivant les instructions techniques prévues pour notre produit. Il est expressément prévu qu' on ne saurait se prévaloir d' un quelconque préjudice contractuel ou réhibitoire si le montage avait été fait en dépit des dites instructions ou dans un garage ne disposant pas des équipements adéquats.

Le type-nr. **PZ402-90470-AB**

est construit pour le véhicule indiqué ci-dessus et ne peut être monter que sur ce véhicule. Pour la fixation, utiliser exclusivement les éléments ci-joints.

ES

Atención! Pretensiones de garantía respectivamente toda clase de reclamaciones a indemnización por danos y perjuicios pueden considerarse por nosotros solamente en caso de un montaje debidamente ejecutado en un taller especializado. Llamamos expresadamente su atención al hecho que un montaje no apropiado y no efectuado en un taller especializado tendrá por consecuencia la renuncia al ejercicio de toda clase, sobre todo originando del título de ley sobre la responsabilidad para productos defectuosos.

El tipo: **PZ402-90470-AB**

està construido para el vehiculo arriba mencionado y puede montarse exclusivamente sobre este vehiculo. Para su fijación se usarán unicamente las piezas de fijación adjuntas.

DE

Achtung! Etwaige Gewährleistungsansprüche bzw. Schadenersatzansprüche aller Art können von uns nur bei einer ordnungsgemäßen und der Anleitung entsprechenden Montage in einer Fachwerkstätte berücksichtigt werden.

Wir weisen ausdrücklich darauf hin, daß eine unsachgemäße und nicht in einer Fachwerkstätte durchgeführte Montage einen Verzicht auf die Geltendmachung jeglicher Art insbesondere auch aus dem Titel des Produkthaftpflichtrechtes bewirkt.

Die Typ-Nr. **PZ402-90470-AB**

ist für das oben angeführte Fahrzeug konstruiert und darf nur auf diesem Fahrzeug montiert werden.

Für die Befestigung sind ausschließlich die beiliegenden Befestigungsteile zu verwenden.

NL

Attentie! Een claim op garantie, resp. op schadeloosstelling, van welke aard ook, kan door ons slechts worden gehonoreerd indien ons produkt deskundig en overeenkomstig de voorschriften door een vakkundige werkplaats gemonteerd is. Wij wijzen er met nadruk op, dat ondeskundige en niet door een vakkundige werkplaats uitgevoerde montage tot gevolg heeft dat daardoor ieder recht op schadevergoeding, ook op wettelijke aansprakelijkheid inzake produkten, vervalt.

Typ-nr. **PZ402-90470-AB**

is voor het boven genoemde voertuig geconstrueerd en mag alleen op dit voertuig gemonteerd worden.

Voor de bevestiging behoren uitsluitend de bijliggende bevestigingsdelen gebruikt te worden.

EN

Important note! Guarantee claims/compensation claims of all kinds can only be entertained by us if assembly has been carried out properly and in accordance with instructions in a specialist workshop.

We would expressly point out that any improper assembly which is not carried out in a specialist workshop will result in the renunciation of the enforcement of compensation claims of any kind, in particular those arising by virtue of the product liability law.

The type no.: **PZ402-90470-AB**

is constructed for the above vehicle and can only be mounted on said vehicle. For the purpose of fixing, please use the attached fixing parts only.

IT

Attenzione! Qualsiasi diritto a garanzia o diritto al risarcimento del danno può essere preso in considerazione solo in caso di un montaggio eseguito in modo regolare, secondo le rispettive istruzioni, in un'officina specializzata. Si fa notare esplicitamente che, in caso di un montaggio non appropriato, fuori di un'officina specializzata, si rinuncia all'esercizio di qualsiasi diritto, soprattutto di quello derivante dal titolo della responsabilità civile del fabbricante o venditore del prodotto.

Il modell: **PZ402-90470-AB**

è stato costruito per il veicolo sopraindicato e può essere montato solo su questo veicolo. Per il fissaggio vanno usati esclusivamente gli elementi di fissaggio acclusi.

PT

Atenção! Quaisquer reivindicações de garantia ou de indemnização apenas poderão ser consideradas por nós se a montagem foi devidamente efectuada numa oficina especializada. Chamamos expressamente a atenção para o facto de que uma montagem não efectuada devidamente e não numa oficina especializada resultará na renúncia do direito a quaisquer reivindicações, em especial á do direito sob a lei da responsabilidade de produtos.

Tipo N° **PZ402-90470-AB**

Foi construido para o veiculo acima referido e só poderá ser montado neste veiculo.

Para a fixação, utilizar apenas as peças de fixação juntas.

Lackieranleitung für grundierte RIGID Teile

1) Der Teil wurde schon grundiert

2) **Schleifen:** Schleifen der Teile mit P 1000 Wasserschleifpapier und wenn Poren sichtbar sind kitten (z.B. Fa. 3M 5960 oder Fa. Spies Hecker 7715)

3) **Wird beim Vorbereiten zum Lackieren die Grundierschicht durchgeschliffen, so ist nochmals zu grundieren** (z.B. Fa. Spies Hecker)

Priomat Elastic-Haftfüller 3305	100 Teile
Priomat Kunststoffverdünnung 8581	50 Teile

4) **Reinigung:**

- Reinigen mit Silikonentferner (z.B. Fa. Spies Hecker 7799)
- Abwischen des Teiles mit einem Staubbindetuch (z.B. Fa. Brill Staubfix)

5) **Decklackierung:**

5a) 1-Schichtlackierung

BASF Serie 21	100 Teile
BASF Elastikzusatz 521 - 111	30 Teile
BASF Härter MS Top 529 - 73	50 Teile
BASF Einstellzusatz 352 - 91	max. 10 %

- Anwendung:

Min. 2 Spritzgänge (bis Deckkraft des Farbtons erreicht ist).

ACHTUNG ABLÜFTEZEITEN ZWISCHEN DEN EINZELNEN SPRITZGÄNGEN BEACHTEN!

- Ablüftezeit vor dem Trocknen mind. 15 Min.

5b) 2-Schichtlackierung

- BASISLACK:

Spies Hecker Serie 293 oder 295	100 Teile
Spies Hecker Verdünnung 3054	50 Teile

- Anwendung:

Min. 2 Spritzgänge (bis Deckkraft des Farbtons erreicht ist).

ACHTUNG ABLÜFTEZEITEN ZWISCHEN DEN EINZELNEN SPRITZGÄNGEN BEACHTEN!

- KLARLACK:

Spies Hecker Klarlack MS plus T30	100 Teile
Spies Hecker Elastikzusatz 8573	30 Teile
Spies Hecker Härter MS plus 3030	50 Teile
Spies Hecker Verdünnung 3054	max. 10 %

- Anwendung:

2 Spritzgänge

ACHTUNG ABLÜFTEZEITEN ZWISCHEN DEN EINZELNEN SPRITZGÄNGEN BEACHTEN!

- Ablüftezeit vor dem Trocknen mind. 15 Min.

6) **Trocknung:**

- Bei max. 50°C für mind. 1 Std. oder Lagerung bei Raumtemperatur über Nacht (Staubtrocken)
- Lagerung für mind. 24 Std. bei Raumtemperatur (vollkommen ausgehärtet)

7) **Polieren:**

- Anwendung:

Sichtbare Staubeinschlüsse mit Schleifblüten (z.B. Fa. 3M 13444) herausschleifen.

Den Teil mit der Polierpaste (z.B. Fa. 3M 5923) und der Poliermaschine

(z.B. Fa. 3M Bohrmaschine + Schleifteller + Buffing Pad) einreiben.

Von Hand mit Glanzpolitur (z.B. Fa. 3M 05990) und sauberer Polierwolle auf Hochglanz polieren.

ACHTUNG HERSTELLERHINWEISE BEACHTEN !!

Painting Procedure for primered RIGID parts

1) Part has already been primed.

2) Sanding: Sand part with P1000 water-sandpaper and putty if pores are visible (e.g. with 5960 from 3M or 7715 from Spies Hecker)

3) Should the primer layer come off during painting preparation due to too much sanding, then primer must be applied again (e.g. Spies Hecker)

Priomat elastic filler 3305	100 parts
Priomat thinner 8581	50 parts

4) Cleaning:

- Clean with silicone remover (e.g. from Spies Hecker 7799)
- Wipe part with a dustbonding cloth (e.g. Brill Staubfix)

5) Top coating:

5a) One-coated paint

BASF Serie 21	100 parts
BASF elastic-admixture 521-111	min. 30 parts
BASF MS top hardener 529-73	50 parts
BASF thinner 352-91	max. 10 %

- application:

Apply at least twice (until colour-tone is achieved)

MAKE SURE TO KEEP THE FLASH-OFF TIME DURING EACH SPRAY STEP!

- Let it air-dry for at least 15 min before undergoing drying procedure.

5b) Two-coated paint

- BASE-PAINT:

Spies Hecker Serie 293 or 295	100 parts
Spies Hecker thinner 3054	50 parts

- application:

Apply at least twice (until colour-tone is achieved)

MAKE SURE TO KEEP THE FLASH-OFF TIME DURING EACH SPRAY STEP!

- CLEAR COAT:

Spies Hecker clear coat MS plus T30	100 parts
Spies Hecker elastic-admixture 8573	min. 30 parts
Spies Hecker hardener MS plus 3030	50 parts
Spies Hecker thinner 3054	max. 10 %

- application:

2 spray steps

MAKE SURE TO KEEP THE FLASH-OFF TIME DURING EACH SPRAY STEP!

- Let it air-dry for at least 15 minutes before undergoing drying-procedure

6) Drying:

- at max. 50 degrees C for at least 1 hour or let it dry overnight at room temperature (dust-dry)
- Storage for at least 24 hours at room temperature (thoroughly hardened)

7) Polishing:

- application:

Sand dust-enclosures with sandpaper (3M 13444)

Rub part with polish-paste (3M 5923) and by means of a polishing-machine (3M drill machine + sander + buffing pad). Polish with shiny polish by hand (3M 05990) and high polish with a clean polishing cloth.

FOLLOW INSTRUCTIONS OF THE PAINT SUPPLIER !!

Instructions de peinture pour pièces en RIGID avec peinture de fond

1) La pièce doit déjà avoir reçu une couche de fond.

2) **Polissage:** polir les pièces au papier-émeri P1000 et mastiquer si des pores sont apparents. (Ex.: Sté 3M 5960 ou Sté Spies Hecker 7715)

3) **Si en ponçant vous avez éliminé une partie de la couche de fond passée avant d'appliquer la laque, il y a lieu d'appliquer une nouvelle sous-couche** (par exemple de la firme Spies Hecker)

Priomat Elastic - produit de coupage adhérent 3305	100 pièces
Priomat diluant plastique 8581	50 pièces

4) **Nettoyage:**

- nettoyer avec un produit à silicone (Ex.: Sté Spies Hecker 7799)

- Essuyer la pièce avec un chiffon antipoussière (Ex.: Sté Bril Staubfix)

5) **Peinture finale:**

5a) **Première couche de peinture**

BASF série 21		100 pièces
BASF additif élastique 521-111	min.	30 pièces
BASF durcisseur MS Top 529-73		50 pièces
BASF additif normalisant 352-91	max.	10 %

- Emploi:

Au minimum 2 pulvérisations de peinture (jusqu'à ce que le pouvoir couvrant de la teinte soit atteint).

ATTENTION! RESPECTER LES TEMPS D' AERATION ENTRE CHAQUE PULVERISATION!

- Temps d' aération avant le séchage: min. 15 minutes.

5b) **Seconde couche de peinture**

- **PEINTURE DE BASE:**

Spies Hecker série 293 ou 295	100 pièces
Spies Hecker diluant 3054	50 pièces

- Emploi:

Au minimum 2 pulvérisations de peinture (jusqu' à ce que le pouvoir couvrant de la teinte soit atteint)

ATTENTION! RESPECTER LES TEMPS D' AERATION ENTRE CHAQUE PULVERISATION!

- **VERNIS TRANSPARENT:**

Spies Hecker vernis transparent MS plus T30		100 pièces
Spies Hecker additif élastique 8573	min.	30 pièces
Spies Hecker durcisseur MS plus 3030		50 pièces
Spies Hecker diluant 3054	max.	10 %

- Emploi: 2 pulvérisations de peinture

ATTENTION! RESPECTER LES TEMPS D' AERATION ENTRE CHAQUE PULVERISATION!

- Temps d' aération avant le séchage: min. 15 minutes.

6) **Séchage:**

- à max. 50 °C pendant 1 heure minimum ou une pose à température ambiante pendant la nuit (hors poussière)

- entreposition de 24 heures minimum à température ambiante (entièrement durci)

7) **Polissage:**

- emploi: polir les impuretés visibles avec papier-émeri (Ex.: Sté 3M 13444).

Enduire la pièce de pâte abrasive à polir (Ex.: Sté 3M 5923) puis au banc à polir

(Ex.: perceuse Sté 3M + disque + meule flexible en laine).

Polir à la main au vernis brillant (Ex.: Sté 3M 05990), puis à la laine à polir propre.

ATTENTION! RESPECTER LES CONSEILS DU FABRICANT !!

Richtlijnen voor lakwerk bij met grondverf behandelde RIGID onderdelen

1) Het onderdeel werd reeds met grondverf behandeld

2) **Schuren:** schuren van de onderdelen met P 1000 water schuurpapier en als er porien zichtbaar zijn, plamuren (Bijvoorbeeld met 3 M 5960 of Firma Spies Hecker 7715).

3) **Als bij de voorbereiding voor het lakken de grondverflaag doorgeslepen wordt, moet er een nieuwe grondverflaag opgebracht worden** (bijv. firma Spies Hecker)

Priomat Elastic-Hechtvuller	100 delen
Priomat Kunststofverdunding 8581	50 delen

4) Reinigen:

- reinigen met silicone-verwijderer (bijv. firma Spies Hecker 7799)
- het onderdeel afwissen met een stofbindingsdoek (bijv. Bril Staubfix)

5) Deklakken:

5a) 1-laaglakkering

BASF Serie 21		100 delen
BASF Elastiekadditief 521-111	min	30 delen
BASF hardingsmiddel MS Top 529-73		50 delen
BASF insteladditief 352-91	hoogstens	10 %

- Behandeling:

Minstens 2 maal spuiten (totdat de kleurtoon bereikt is)

ATTENTIE! TUSSEN DE AFZONDERLIJKE SPUITLAGEN MOETEN DE LUCHTINGSTIJDEN IN ACHT WORDEN GENOMEN!

- Luchtingstijden voor het drogen: minstens 15 minuten.

5b) 2-laaglakkering

- **BASISLAK:**

Spies Hecker serie 293 of 295	100 delen
Spies Hecker verdunding 3054	50 delen

- Behandeling: minstens 2 maal spuiten (totdat de kleurtoon bereikt is)

ATTENTIE! TUSSEN DE AFZONDERLIJKE SPUITLAGEN MOETEN DE LUCHTINGSTIJDEN IN ACHT WORDEN GENOMEN!

- **KLAARLAK:**

Spies Hecker Klarlack MS plus 30	100 delen
Spies Hecker Elastiekadditief 8573	min 30 delen
Spies Hecker hardingsmiddel MS plus 3030	50 delen
Spies Hecker verdunding 3054	hoogstens 10 %

- Behandeling: 2 maal spuiten

ATTENTIE! TUSSEN DE AFZONDERLIJKE SPUITLAGEN MOETEN DE LUCHTINGSTIJDEN IN ACHT WORDEN GENOMEN!

- Luchtingstijden voor het drogen: minstens 15 minuten.

6) Drogen:

- Minstens 1 uur bij hoogstens 50°C of bij kamertemperatuur gedurende de nacht (stofdroog)
- Minstens 24 uur drogen bij kamertemperatuur (volledige verharding).

7) Polijsten:

- Behandeling:

Zichtbare stofdeeltjes met speciaal schuurpapier (bijv. van de Firma 3M 13 444) uitschuren; het onderdeel met polijstpasta (bijv. 3M 5923) en met een polijstmachine (bijv. 3M boormachine + polijtschijf + buffing pad) insmeren. Handmatig polijstmiddel aanbrengen (bijv. 3M 05990) en met reine polijstwol op hoogglans polijsten.

ATTENTIE: VOLG DE AANWIJZINGEN VAN DE FABRIKANT !!

CHECK SHEET



TOYOTA

Model / Year

Aygo 2005

Roof spoiler

VIN n°

ALWAYS A
BETTER WAY

 **P/N = OK**

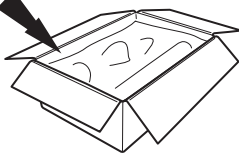

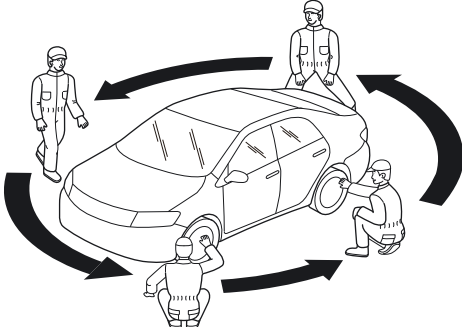

 = OK

Installation Date:

.. / .. / ..

Technician Name & Signature:

Stamp:

