



**TOYOTA**

ALWAYS A  
**BETTER WAY**

# Corolla (HB)

## Towing hitch vertical detachable

Installation Instructions

Model year: 2019/01  
Vehicle code: \*\*E\*1\*\*-DH\*\*\*\*  
Part number: PW960-02004

Manual reference number: AIM 004 240-1

<p><b>GB FITTING INSTRUCTIONS - TOWBAR</b></p> <p>Type: 6238 D-value: 8,5 kN Vertical coupling load towbar: 75 kg Manufacturer: Brink B. V., Postbox 24</p> <p>Model Application: NL 7950 AA Staphorst EC-Type Approval No.: Corolla (HB) E11 55R 0111085</p> <p>A50-X <b>Expert Fitting Required</b> Ensure that this fitting instructions is passed to the customer In order to use the trailer hitch, simultaneous installation of an electrical kit is required. (Cable set not included!)</p> <p>Remove undersealing, anti-corrosion wax and noise-deadening material in the area of the contact surfaces. Apply corrosion protection material as specified in the TOYOTA service guidelines, where necessary.</p> <p>After approximately 1000 km of trailer use, retighten all bolts to the correct torque values.</p> <p>For correct trailer loads please refer to vehicle documents of the individual vehicle model.</p> <p>The coupling ball must be kept clean and well greased*.</p> <p>*EXCEPTION: When stabilizers are used, proceed according to the instructions of the manufacturers of the stabilizer. In this case coupling ball must be inspected for wear at regular intervals. The trailer coupling must be installed and inspected in accordance with the applicable national regulations.</p>	<p><b>D ANBAUANWEISUNG FÜR ANHÄNGEVORRICHTUNG</b></p> <p>Typ: 6238 D-Wert: 8,5 kN Stützlast Anhängervorrichtung: 75 kg Hersteller: Brink B. V., Postbox 24</p> <p>Verwendungsbereich: NL 7950 AA Staphorst EWG-Typgenehmigung Nr.: Corolla (HB) E11 55R 0111085</p> <p>A50-X <b>Einbau von einer Fachwerkstatt durchführen lassen.</b> <b>Diese Einbauanweisung ist dem Kunden auszuhandigen.</b></p> <p>Zum Betreiben der Anhängervorrichtung ist der gleichzeitige Einbau eines Elektrobausatzes erforderlich. (Kabelset nicht mitgeliefert!)</p> <p>Im Bereich der Anlageflächen muß Unterbodenschutz, Hohlraumkonservierung (Wachs) und Antidröhnmaterial entfernt werden. Wo erforderlich, Korrosionsschutz entsprechend den TOYOTA-Service Richtlinien vornehmen. Nach 1000 km Anhängerbetrieb alle Befestigungsschrauben mit vorgeschriebenem Drehmoment nachziehen. Die für das jeweilige Fahrzeugmodell verbindlichen Anhängelasten sind den Fahrzeugpapieren zu entnehmen. Die Kupplungskugel ist sauber zu halten und zu fetten*. *AUSNAHME: Bei Verwendung von Stabilisierungseinrichtungen nach den Anweisungen des Herstellers der Stabilisierungseinrichtung vorgehen. Ebenfalls muß bei Verwendung einer solchen Stabilisierungseinrichtung die Kupplungskugel in regelmäßigen Abständen auf Verschleiß untersucht werden.</p> <p>Der Anbau hat nach dieser Anbauanweisung zu erfolgen und ist gem. §§ 19, 20 oder 21 StVZO durch einen amtlich anerkannten Prüfer oder Sachverständigen zu überprüfen. Die Typgenehmigung der Anhängervorrichtung und diese Anbauanweisung sind dabei vorzulegen. Anbau, Überprüfung und Genehmigung der Anhängervorrichtung müssen den gültigen gesetzlichen Bestimmungen entsprechend durchgeführt werden.</p>	<p><b>D</b> Der grundsätzliche Anbau der Anhängervorrichtung nach Anhang I, Nr. 5.10 in Verbindung mit Anhang VII der Richtlinie 94/20/EG ist überprüft:</p> <ul style="list-style-type: none"> <li>* Die vom Fahrzeughersteller serienmäßig genehmigten Befestigungspunkte sind einzuhalten.</li> <li>* Die Vorgaben zum Freiraum um die Kugel beziehungsweise über der Kugel sowie zur erforderlichen Höhe der Kugel über der Fahrbahn (Anhang VII, Abbildung 30 der Richtlinie 94/20/EG) sind beim serienmäßigen Fahrzeug gewährleistet.</li> <li>* Die Kenndaten D-Wert und zul. statische Stützlast der Anhängervorrichtung sowie das amtliche Prüfzeichen befinden sich auf dem Typschild.</li> <li>* Nur im Anhängerbetrieb darf das rückwärtige amtliche Kennzeichen durch die Kugel verdeckt werden, ansonsten ist sie abzunehmen und im Kofferraum befestigt mitzuführen.</li> </ul> <p><b>Diese Montage- und Betriebsanleitung ist im Fahrzeug mitzuführen und ggf. berechtigten Personen vorzulegen.</b></p> <p>Der Eintrag dieser EG-geprüften Anhängervorrichtung in die Fahrzeug-Papiere ist nicht (mehr) erforderlich; allerdings wird insbesondere bei Selbstmontage empfohlen, das Fahrzeug nach dem ordnungsgemäßen Anbau der Anhängervorrichtung bei einer auf den Anbau von BRINK Anhängervorrichtungen geschulten Fachwerkstätte vorzuführen, damit die Einhaltung aller Bedingungen nochmals überprüft wird.</p> <p><b>Montagehinweise:</b></p> <p>Die Anhängervorrichtung ist ein Sicherheitsteil. Deshalb darf sie nur sach- und fachgerecht montiert werden.</p> <p>Jegliche Änderungen bzw. Umbauten an der Anhängervorrichtung sind verboten. Sie führen zum Erlöschen der Genehmigung.</p> <p>Isoliermasse bzw. Unterbodenschutz am Fahrzeug -falls vorhanden -im Bereich der Anlageflächen der Anhängervorrichtung sind zu entfernen. Blanke Karosserieteile sowie Bohrungen mit Rostschutz versiegeln.</p> <p>Falls erforderlich, Korrosionsschutz entsprechend den Toyota-Service-Richtlinien vornehmen.</p> <p><b>Betriebshinweise:</b></p> <p>Sämtliche Befestigungsschrauben der Anhäng-</p>	<p><b>D</b> vorrichtung sind nach circa 1000 Anhänger - km mit den vorgeschriebenen Anzugsdrehmomenten nachziehen.</p> <p>Die Kupplungskugel ist sauber zu halten und leicht zu fetten. Die Verwendung einer Schutzkappe wird empfohlen. Werden jedoch Stabilisierungseinrichtungen verwendet, muß die Kupplungskugel fettfrei sein. Die Hinweise in den diesbezüglichen Betriebsanleitungen sind zu beachten.</p> <p>Sobald an einer beliebigen Stelle ein Kupplungskugel-Durchmesser von 49,0 mm oder kleiner erreicht ist, darf die Kugel der Anhängervorrichtung aus Sicherheitsgründen nicht mehr weiter benutzt werden.</p> <p>Das Leergewicht des Fahrzeuges erhöht sich nach Montage der Anhängervorrichtung um circa 20 kg.</p> <p>Die zulässige Anhängelast und statische Stützlast für das Fahrzeug sind zu beachten. Diese Angaben sind in der Bedienungsanleitung des Fahrzeuges und in den Fahrzeug-Papieren vermerkt. Kontrolle: Die auf dem Fabrikschild der Anhängervorrichtung aufgeführten Daten müssen gleich oder größer sein als die vom Fahrzeughersteller genehmigten Daten. Falls sie größer sind, bleiben die vom Fahrzeughersteller genehmigten Daten gültig.</p>
<p><b>E INSTRUCCIONES DE MONTAJE PARA EL DISPOSITIVO DE REMOLQUE</b></p> <p>Typo: 6238 Valor-D: 8,5 kN Carga de apoyo de remolque: 75 kg Fabricante: Brink B. V., Postbox 24</p> <p>Campo de aplicación: NL 7950 AA Staphorst la CEE nº: Corolla (HB) E11 55R 0111085</p> <p>A50-X <b>El montaje deberá ser realizado por un taller especializado</b> <b>Estas instrucciones de montaje deben ser entregadas al cliente.</b></p> <p>Para el funcionamiento del dispositivo de remolque hace falta al mismo tiempo el montaje de un conjunto eléctrico. (Juego de cables no viene incluido)</p> <p>En el área de las superficies de apoyo han de eliminarse la protección del fondo, la conservación del espacio hueco (cera) y el material antiresonante.</p> <p>En caso de necesidad, efectuar la protección anticorrosiva de acuerdo con las directrices de servicio de TOYOTA.</p> <p>Al cabo de 1.000 km. de funcionamiento de remolque, reparar todos los tornillos de fijación con el par de fuerzas especificado.</p> <p>Las cargas de remolque admisibles para cada modelo respectivo de vehículo se pueden ver en la documentación del mismo.</p> <p>La bola de acoplamiento ha de mantenerse limpia y engrasarse*. * EXCEPCIÓN: En caso de utilización de dispositivos de estabilización, deberá procederse de acuerdo con las instrucciones del fabricante del dispositivo de estabilización. Igualmente, al utilizar tal dispositivo de estabilización, la bola de acoplamiento ha de examinarse a intervalos regulares en cuanto a su desgaste.</p> <p>El montaje, la comprobación y la autorización del dispositivo de remolque deberán efectuarse de acuerdo con las disposiciones legales válidas.</p>	<p><b>F NOTICE DE MONTAGE DE L'ATTELAGE</b></p> <p>Type: 6238 Valeur D: 8,5 kN Charge d'appui de l'attelage: 75 kg Fabricant: Brink B. V., Postbox 24</p> <p>Domaine d'utilisation: NL 7950 AA Staphorst N° d'homologation de la CE: Corolla (HB) E11 55R 0111085</p> <p>A50-X <b>Confier le montage à un atelier spécialisé</b> <b>Cette notice de montage doit être remise au client.</b></p> <p>L'utilisation du dispositif de remorquage implique le montage simultané d'un set électrique. (Faisceau de câbles non fourni !)</p> <p>La protection du dessous de caisse, la cire de conservation des corps creux et le produit d'insonorisation doivent être enlevés.</p> <p>Procéder à la protection contre la corrosion là où nécessaire et conformément aux directives de TOYOTA-Service.</p> <p>Après avoir tracté une remorque sur 1000 km resserrer toutes les vis de fixation au couple prescrit.</p> <p>Les charges pouvant être tractées par chacun des modèles sont prescrites dans les papiers du véhicule.</p> <p>La rotule doit toujours être propre et graissée*. * EXCEPTION: En cas d'utilisation de dispositifs de stabilisation, procéder selon les instructions du fabricant du dispositif de stabilisation. La rotule doit également être périodiquement vérifiée quant à son usure éventuelle si un tel dispositif de stabilisation est employé.</p> <p>Le dispositif de remorquage doit être monté, vérifié et autorisé conformément aux dispositions légales en vigueur.</p>	<p><b>I INSTRUZIONE DI MONTAGGIO DEL DISPOSITIVO DI TRAINO</b></p> <p>Typo: 6238 Valore-D: 8,5 kN Carico del timone di traino: 75 kg Produttore: Brink B. V., Postbox 24</p> <p>Campo d'uso: NL 7950 AA Staphorst EURO approval No.: Corolla (HB) E11 55R 0111085</p> <p>A50-X <b>Il montaggio dev'essere affidato a un'officina specializzata.</b> <b>Le presenti istruzioni di montaggio devono essere consegnate al cliente.</b></p> <p>Per l'utilizzazione del dispositivo di traino è necessaria l'applicazione di un relativo impianto elettrico. (Set di cavi non in dotazione)</p> <p>Allontanare la protezione sottococca, il trattamento antiruggine dei recessi irraggiungibili (cera) e la massa antirumo nell'ambito delle superfici di contatto.</p> <p>Se e dove necessario applicare la protezione anticorrosione attenendosi alle direttive service TOYOTA.</p> <p>Dopo 1000 km di uso del traino, stringere di nuovo tutte le viti di fissaggio con il momento torcente prescritto.</p> <p>Il peso massimo trainabile vincolante per il rispettivo modello di veicolo trainante è riportato nella rispettiva documentazione tecnica del veicolo.</p> <p>L'aggancio a sfera dev'essere mantenuto pulito e ingrassato (*). (* EXCEZIONE: Nel caso vengano impiegati dispositivi di stabilizzazione attenersi alle istruzioni del produttore del dispositivo di stabilizzazione. Nel caso d'impiego di un tale dispositivo di stabilizzazione è pure necessario di controllare a regolari intervalli di tempo il grado di usura dell'aggancio a sfera.</p> <p>Il montaggio, la revisione ed il collaudo del dispositivo di traino dovranno essere eseguiti nel rispetto della normativa legale vigente.</p>	<p><b>P INSTRUÇÕES DE MONTAGEM PARA DISPOSITIVO DE REBOQUE</b></p> <p>Typo: 6238 Valor D: 8,5 kN Capacidade de carga de reboque: 75 kg Fabricante: Brink B. V., Postbox 24</p> <p>Campo de utilização: NL 7950 AA Staphorst N° de autorização CEE: Corolla (HB) E11 55R 0111085</p> <p>A50-X <b>Mandar efectuar a montagem em uma oficina especializada</b> <b>Estas instruções de montagem deverão ser entregues ao cliente.</b></p> <p>Para operação deste dispositivo de reboque, é necessário montar um conjunto eléctrico simultaneamente. (O conjunto de cabos não está incluído)</p> <p>Na superfície do sistema deverá ser removida a protecção inferior da carroçaria, conservante de espaços ocios (cera) e material anti-ruído.</p> <p>Efectuar as medidas de protecção anti-corrosiva onde for necessário, de acordo com as directrizes de serviço da TOYOTA.</p> <p>Reapertar todos parafusos de fixação com o binário de aperto prescrito após 1000 km.</p> <p>As cargas de reboque permitidas autorizadas para cada modelo de veículo podem ser vistas nos documentos do veículo.</p> <p>A bola do engate de reboque deverá ser mantida limpa e lubrificada*. * EXCEPÇÃO: Utilizar dispositivos estabilizadores de acordo com as instruções de operação dos fabricantes dos dispositivos. Da mesma forma deve controlar a bola do engate em intervalos regulares quanto à desgaste no caso de se utilizar tais dispositivos estabilizadores.</p> <p>A montagem, controle e autorização do dispositivo de reboque deverão ser executados de acordo com as normas legais.</p>

**NL MONTAGE-INSTRUCTIE VOOR TREKHAAK**

Type:	6238
D-waarde:	8,5 kN
Draglast trekhaak:	75 kg
Fabrikant:	Brink B. V. Postbox 24 NL 7950 AA Staphorst Corolla (HB)
Toepassingsgebied:	E11 55R 0111085
EEG-typegoedkeuring nr.:	

A50-X

Montage door een erkende garage laten uitvoeren. Deze montage-instructie moet aan de klant worden gegeven.

Om de trekhaak te kunnen gebruiken is montage van een passende kabelset noodzakelijk. **(Kabelset niet meegeleverd)**

Op de contactvlakken de tectyl, conservering van holle ruimten (was) en anticreunmateriaal verwijderen.

Waar nodig corrosiebescherming overeenkomstig de richtlijnen van de TOYOTA-service aanbrengen.

Na 1000 km gebruik van de aanhanger alle bevestigingsbouten met het voorgeschreven draaimoment vastdraaien.

De voor het desbetreffende model auto bindend toegestane gewichten van de aanhangwagen staan in het kentekenbewijs vermeld.

De koppelingsskogel moet schoon gehouden en ingevet worden\*.

\* UITZONDERING: Bij gebruik van stabilisatie-inrichting volgens de aanwijzingen van de fabrikant van de stabilisatie-inrichting te werk gaan. Ook moet bij het gebruik van een dergelijke stabilisatie-inrichting de koppelingsskogel regelmatig op slijtage worden onderzocht.

Monteren, controleren en goedkeuring van de aanhanginrichting moeten overeenkomstig de geldende wetelijke bepalingen worden uitgevoerd.

**DK MONTERINGSVEJLEDNING FOR ANHÆNGERTRÆK**

Type:	6238
D-Værdi:	8,5 kN
Støttebelastning anhængertræk:	75 kg
Producent:	Brink B. V. Postbox 24 NL 7950 AA Staphorst Corolla (HB)
Anvendelsesområde:	E11 55R 0111085
EWG-typegodkendelse nr.:	

A50-X:

Monteringen skal foretages af et godkendt værksted.

Denne monteringsvejledning skal udleveres til kunden.

For at kunne anvende anhængertrækket kræves samtidig montering af et el-monterings sæt.

**(Kabelset ikke vedlagt)**

På anlægsfladerne skal undervognsbeskyttelsen, hulrumsconserveringen (voks) og lyd dæmpende materialer fjernes.

Korrosionsbeskyttelse foretages iht. retningslinjerne fra TOYOTA-Service, hvor dette er påkrævet.

Efter 1000 km kørsel med anhængertrækket skal alle fastgørelseskruer efterspændes med det foreskrevne drejningsmoment.

De påhængslaster, der er tilladt for den pågældende bilmodel, kan ses i bilens papirer.

Koblingskuglen skal holdes ren og indfedtes\*.

\* UNDTAGELSE: Ved anvendelse af stabiliseringsanordninger skal man gå frem i henhold til anvisningerne fra producenten af stabiliseringsanordningen. Ligeledes skal koblingskuglen ved anvendelse af en sådan stabiliseringsanordning jævnligt undersøges for slijtage.

Montering, test og godkendelse af anhængertrækket skal gennemføres i overensstemmelse med gældende lovmæssige bestemmelser.

**N MONTERINGSANVISNING FOR TILHÆNGERFESTE**

Type:	6238
D-verdi:	8,5 kN
Støttebelastning tilhængerfeste:	75 kg
Producent:	Brink B. V. Postbox 24 NL 7950 AA Staphorst Corolla (HB)
Bruksområde:	E11 55R 0111085
EWG-typegodkendelse:	

A50-X

Monteringen må foretas af et fagværksted. Denne monteringsanvisningen må overleveres til kunden.

For bruk av tilhengerfestet er det nødvendig med samtidig montering av en elektrobyggekomponent. **(Ledningsknippe ikke inkludert)**

I festeområdet må understellbehandlingen, hulromskonserveringen (voks) og antistoy materialet fjernes.

Dersom nødvendig må korrosjonsbeskyttelsen foretas i henhold til TOYOTA service-retningslinjer.

Efter 1000 km tilhengerdrift må alle festeskruene skrues fast igjen med foreskrevet dreiemoment.

De tilhengerlastene som gjelder for de respektive kjøretøymodellene finnes i vognkortet.

Kopplingskulan må alltid holdes ren og må smøres inn\*.

\*Unntak: Ved bruk av stabiliseringsinnretninger, må det gås fram etter anvisning fra produsenten av disse. Likeledes må ved bruk av slike stabiliseringsinnretninger kopplingskulan undersøkes med regelmessige mellomrom for slitasje.

Montering, kontroll og tillatelse til tilhengerfestet må gjennomføres i henhold til de gyldige, lovfestede bestemmelser.

**S MONTERINGSANVISNING FÖR FÄSTE FÖR KOPPLINGSKULA**

Typ:	6238
D-värde:	8,5 kN
Stödbelastning för dragkrok:	75 kg
Tillverkare:	Brink B. V. Postbox 24 NL 7950 AA Staphorst Corolla (HB)
Användningsområde:	E11 55R 0111085
EURO approval No.:	

A50-X

Låt montage utföras av en bilverkstad. Denna monteringsanvisning skall överlämnas till kunden.

För att kunna använda släpvagnskopplingen är det nödvändigt att montera den tillhörande elektriska monteringsattsan. **(Kabelset inkluderas ej)**

På anläggningsytorna måste underredsbekhandling, hålrumskonservering (vax) och ljudisoleringsmassa avlägnas.

Där så erfordras skall korrosionsskydd utföras enligt riktlinjerna för TOYOTA service.

Efter 1000 km körning med släpvan skall alla fastskruvar efterdras med föreskrivet åtdragningsmoment.

Den för respektive bilmodell gällande högsta tillåtna släpfordonsvikten framgår av bilens registreringsbevis.

Kopplingskulan skall hållas ren och infettas\*.

\* UNDTAG: Vid användning av stabiliseringsanordningar som verkar på kopplingskulan, skall man följa anvisningarna från tillverkaren av stabiliseringsanordningen. Vid användning av en sådan stabiliseringsanordning måste kopplingskulan regelbundet undersökas med avseende på slitage.

Montering och kontroll av släpvagnskopplingen måste utföras enligt gällande lagstadgade bestämmelser.

**SF VETOLAITTEEN ASENNUSOHJE**

Typi:	6238
D-arvo:	8,5 kN
Vetokoukun suurin vertikaalinen kytkinkuormitus:	75 kg
Valmistaja:	Brink B. V. Postbox 24 NL 7950 AA Staphorst Corolla (HB)
Käyttöalue:	E11 55R 0111085
EWG-tyypinhyväksyntä nro:	

A50-X

Aseennuksen suorittaa merkkikorjaamo.

Tämä asennusohje annetaan asiakkaille.

Vetolaiteen käyttöä varten on tarpeen asentaa samanlaisesti sähkösarja. **(Kaapeliseti ei kuulu toimitukseen)**

Aseennuskohdista on poistettava pohjamaassa, tyhjän tilan säilöntä (vaha) ja melunestoaine.

Korroosiosuojaa käytetään tarvittaessa kohdin TOYOTA huollon antamien ohjeiden mukaan.

Kiristä kaikki kiinnitysruuvit määrättyllä vääntömomentilla, kun vetokoukku on ollut käytössä 1000 km.

Jokaisen ajoneuvomallin sitovat sallitut vetokoukumat on ilmoitettu ajoneuvon paperissa.

Kytkimen nappi on pidettävä puhtaana ja rasvattavana.\*

\* POIKKEUS: Käytettäessä vakauslaitteita menettään vakauslaitteen valmistajan antamien ohjeiden mukaan. Samoin on käytettäessä vakauslaitetta tarkastettava kytkimen nupin kuluminen säännöllisin väliajoin.

Vetolaiteen asennus, tarkastus ja hyväksyntä on tehtävä voimassa olevien lakien ja säännösten mukaan.

**CZ INSTRUKCE K MONTÁŽI ZÁVUSNĚHO**

Typ:	6238
Hodnota D:	8,5 kN
Maximální vertikální spojovací zařízení záchytného háku:	75 kg
Výrobce:	Brink B. V. Postbox 24 NL 7950 AA Staphorst Corolla (HB)
Oblast použití:	E11 55R 0111085
Čís. povolení typu EHS:	

A50-X

Nechte montáž provést ve specializované dílně.

Tuto montážní instrukci je třeba předat zákazníkovi.

Pro provoz závusného zařízení je zapotřebí současně instalace montážní soupravy elektro. **(Sada kabelů se nedodává společně s výrobkem!)**

V oblasti ploch zařízení je třeba odstranit ochranu podvozku proti korozi, konzervaci dutin (voks) a tlumicí prostředek.

Kde je to zapotřebí, ošetřete ochranným prostředkem proti korozi podle Servisu směrnic TOYOTA.

Po 1000 km provozu s přívěsem dotáhně všechny šrouby předepsaným utahovacím momentem.

Dovolené hmotnosti přívěsu pro příslušný model vozidla jsou uvedeny v dokladech k vozidlu.

Kouli spojky je třeba udržovat v čistotě a mazat jí\*.

\* VÝJIMKA: Při použití stabilizačních zařízení postupujte podle pokynů výrobce stabilizačního zařízení. Rovněž je třeba při použití takového stabilizačního zařízení v pravidelných intervalech kontrolovat opotřebení koule spojky.

Montáž, kontrola a povolení závusného zařízení musí odpovídat platným zákonným ustanovením.

**H A LESZERELHETŐ VONTATÓBERENDEZÉS FELSZERELÉSI**

Tipus:	6238
D-érték:	8,5 kN
A vontatórúd max. függőleges összekapcsolási terhelése:	75 kg
Gyártó:	Brink B. V. Postbox 24 NL 7950 AA Staphorst Corolla (HB)
Melyik gépjárműhöz:	E11 55R 0111085
EGK-típusengedély száma:	

A50-X

Ezt a munkát csak egy szakműhelyen szabad elvégezni. **Kérjük adja át ezt a felszerelési utasítást a Vevőnek.**

A vontatóberendezés üzemeltetéséhez egy megfelelő elektromos szerelékészlet is be kell építeni. **(A vezetékcsomag nincs a szállítványban!)**

A felkészési felületéknél és azok közvetlen környezetében el kell távolítani az alvázvédőréteget, az üregkitöltő konzerválóanyagokat (viaszt) és a berezéggátló borítást.

Ahol szükséges, a felületeket a TOYOTA-szervíz előírásainak megfelelő korrozóvédelemmel kell ellátni.

Miután a vontatóberendezéssel és utánfutóval 1000 km-t megtett, az előírt forgatónyomatékkal ismét húzza meg az összes rögzítőcsavart.

A mindenkori gépjárműmodellhez megengedett vontatható maximális súly a gépjármű formái engedélyében található.

A kuplunggömböt mindig tisztán kell tartani és be kell zsírozni\*.

\* KIVÉTEL: Ha stabilizálóberendezést használ, akkor a stabilizálóberendezést gyártó cég előírásának megfelelően kell eljárni. Ilyen esetekben a kuplunggömb kopását rendszeres időközönként ellenőrizni kell.

A vontatóberendezés felszerelését, ellenőrzését és engedélyezését az érvényben lévő törvényes előírásoknak megfelelően kell végrehajtani.

**PL INSTRUKCJA MONTAŻU WYPOSAŻENIA HOLOWNICZEGO**

Typ:	6238
Wartość D:	8,5 kN
Maksymalne pionowe obciążenie zorca holowniczego:	75 kg
Producent:	Brink B. V. Postbox 24 NL 7950 AA Staphorst Corolla (HB)
Zakres stosowania:	E11 55R 0111085
Nr. zezwolenia EWG:	

A50-X

Montaż zlecić specjalistycznemu warsztatowi. **Niniejszą instrukcję należy wręczyć klientowi.**

W celu eksploatacji wyposażenia holowniczego, konieczne jest jednoczesne zamontowanie modułu elektrycznego. **(Zestaw kablowy nie jest dołączony!)**

W strefie powierzchni przylegania musi być usunięte zabezpieczenie podłogi, zabezpieczenie przestrzeni wewnętrznych (wosk) oraz materiały wyciszające.

Tam, gdzie to konieczne, wykonać zgodnie z zaleceniami serwisu firmy TOYOTA zabezpieczenie antykorozyjne.

Po 1000 km używania przyczepy należy doreć wszystkie śruby mocujące stosując przy tym przepisany moment dokręcający.

Obowiązujące, dopuszczalne do doczepiania ciężary są podane dla każdego modelu pojazdu w jego dokumentach.

Sprzęg kulowy należy utrzymywać w czystości i smarować go.

\*WYJĄTEK: W przypadku używania wyposażenia stabilizującego należy postępować zgodnie ze wskazaniami producenta tego wyposażenia. Także przy używaniu takiego wyposażenia, sprzęg kulowy musi być regularnie poddawany kontroli na stan jego użycia.

Montaż, kontrola i udzielenie zezwolenia dla wyposażenia holowniczego musi być dokonywane zgodnie z ważnymi postanowieniami prawnymi.



<p><b>RO</b> INSTRUCȚIUNI DE MONTARE – BARĂ DE TRACTARE</p> <p>Tip: 6238 Valoare D: 8,5 kN Sarcina barei de tractare la cuplarea verticală: 75 kg Producător: Brink B.V. Postbox 24 NL 7950 AA Staphorst</p> <p>Aplicare model: Corolla (HB) Nr. aprobare tip CE: E11 55R 0111085</p> <p>A50-X</p> <p>Este necesară montarea de către un specialist</p> <p>Asigurați-vă că aceste instrucțiuni de montare sunt înmânate clientului.</p> <p>Pentru a utiliza cârligul de remorcare, este necesară instalarea simultană a unui kit electric. (Setul de cabluri nu este inclus)</p> <p>Îndepărtați învelișul de ceară anticorozivă și materialul antifonant în zona suprafețelor de contact.</p> <p>Unde este necesar aplicați material de protecție anticorozivă după cum este specificat în ghidul de service TOYOTA.</p> <p>După aproximativ 1000 km de utilizare a remorcii, restrângeți toate șuruburile la valorile de cuplu corecte.</p> <p>Pentru sarcinile de remorcare corecte consultați documentele vehiculului în funcție de model. Bila de cuplare trebuie menținută curată și bine lubrifiată*.</p> <p>*EXCEPȚIE: Când se utilizează stabilizatori, respectați instrucțiunile producătorului acelor stabilizatori. În acest caz bila de cuplare trebuie inspectată pentru uzură la intervale regulate.</p> <p>Sistemul de cuplare al remorcii trebuie instalat și inspectat în conformitate cu reglementările naționale în vigoare.</p>	<p><b>SK</b> POKYNY PRE MONTÁŽ – ŤAŽNÉ ZARIADENIE</p> <p>Typ: 6238 Hodnota D: 8,5 kN Maximálne vertikálne zaťaženie ťažného zariadenia: 75 kg Výrobca: Brink B.V. Postbox 24 NL 7950 AA Staphorst</p> <p>Použitie na model: Corolla (HB) Schválenie typu EK č.: E11 55R 0111085</p> <p>A50-X</p> <p>Vyžaduje sa montáž odborníkmí</p> <p>Upíšte sa, že tieto pokyny pre montáž budú odovzdané zákazníkovi.</p> <p>Pre použitie ťažného zariadenia je súčasne potrebná inštalácia elektrickej výbavy. (súprava káblov nie je súčasťou dodávky!)</p> <p>V priestore styčných plôch je potrebné odstrániť tenšie, protikorózný vosk a materiál na tmenie hluku.</p> <p>Podľa potreby aplikujte materiál na ochranu pred koróziou tak, ako je uvedené v servisných smerniciach TOYOTA.</p> <p>Približne po 1000 km používania príviesu dotiahnite všetky skrutky na správne hodnoty krútiaceho momentu.</p> <p>Informácie o povolených hmotnostiach príviesov možno nájsť v dokumentoch k danému modelu vozidla.</p> <p>Ťažná guľa musí byť udržiavaná v čistote a namazaná vazelínou*.</p> <p>*VÝNIMKA: Ak sa používajú stabilizátory, postupujte podľa pokynov výrobcu stabilizátorov. V takom prípade sa ťažná guľa musí v pravidelných intervaloch kontrolovať na opotrebovanie.</p> <p>Ťažné zariadenie sa musí namontovať a skontrolovať v súlade s platnými národnými predpismi.</p>	<p><b>RUS</b> ИНСТРУКЦИЯ ПО МОНТАЖУ БУКСИРНОГО КРЮКА</p> <p>Модель: 6238 Коэффициент D (определяется по массе автомобиля и прицепа): 8,5 kN Вертикальная нагрузка на буксирный крюк: 75 kg Производитель: Brink B.V. Postbox 24 NL 7950 AA Staphorst</p> <p>Диапазон использования: Corolla (HB) Номер разрешения по нормам ЕС для данной модели: E11 55R 0111085</p> <p>A50-X</p> <p>Монтаж должен выполняться сертифицированной автомастерской.</p> <p>Настоящая инструкция по монтажу должна предоставляться заказчику.</p> <p>Для того чтобы буксирный крюк можно было использовать, необходимо смонтировать соответствующие данной модели провода (провода в комплект поставки не входят!)</p> <p>Удалить текстиль с контактных поверхностей, средства консервации (восковой состав) из полостей и антишумовой материал.</p> <p>Где необходимо, нанести антикоррозийное покрытие в соответствии с нормами сервиса для моделей TOYOTA.</p> <p>После пробега прицепом 1000 км затянуть все крепежные болты, используя ключ с заданным крутящим моментом.</p> <p>Допустима для данной модели автомобиля масса прицепа указана в техническом паспорте автомобиля. Сцепной шар должен быть чистым и покрыт смазкой*.</p> <p>* ИСКЛЮЧЕНИЕ: при использовании стабилизирующих приспособлений руководствоваться указаниями производителя данных приспособлений. В случае применения подобных стабилизирующих приспособлений регулярно проверять износ сцепного шара.</p> <p>Монтаж, контроль и сертификация прицепа должны выполняться в соответствии с действующими законоположениями.</p>	<p><b>TR</b> ÇEKİ DEMİRİ MONTAJ TALİMATLARI</p> <p>Tipi: 6238 D-değeri: 8,5 kN Çeki demirinin dikey çekme yükü: 75 kg İmalatçı: Brink B.V. Postbox 24 NL 7950 AA Staphorst</p> <p>Uygulama alanı: Corolla (HB) Avrupa Ekonomik Topluluğu (EEG) onay numarası: E11 55R 0111085</p> <p>A50-X</p> <p>Montajı onaylı bir oto tamircisinde yaptırın</p> <p>Bu montaj talimatları müşteriye verilmelidir.</p> <p>Çeki demirini kullanmak için uygun kablo takımını alması gereklidir. (Kablo takımını birlikte verilmeyecektir.)</p> <p>Temas yüzeylerinde gres, koruyucu katman ve sürtünmeye karşı maddeyi uzaklaştırın.</p> <p>Gerekliğinde sürünmeye karşı korumayı TOYOTA-servis kurallarıyla uyumlu olarak sürün.</p> <p>Yaklaşık 1000 km kullandıktan sonra bütün somun ve civataları talimatlara uygun olarak tekrar sıkın.</p> <p>Her model için geçerli olan çekme ağırlıklı araba ruhsat evrakında belirtilmiştir.</p> <p>Çeki demiri topuzu temiz tutulmalı ve yağlanmalıdır*.</p> <p>* İSTİSNA: Sabitleme aletlerinin kullanılması durumunda, bu sabitleme aletinin üreticisinin kurallarına göre davranın. Sabitleme aletlerinin kullanılması durumunda da çeki demiri topuzunun düzenli olarak aşınmaya karşı kontrol edilmesi gerekir.</p> <p>Çeki demiri ve çekme arabasının montaj, kontrol ve muayenesi çekme teçhizatı için geçerli olan yasa kurallarına göre yapılmalıdır.</p>
<p><b>BG</b> Инструкции за монтаж – ТЕГЛИЧ</p> <p>Тип: 6238 D-стойност: 8,5kN Вертикално съвързване на товарния теглич: 75 kg Производител: Brink B.V. Postbox 24 NL 7950 AA Staphorst</p> <p>Модел на приложението: Corolla (HB) ЕС-тип одобрение №: E11 55R 0111085</p> <p>A50-X</p> <p>Монтажът трябва да се извърши от специалисти.</p> <p>Направете така, че тези инструкции за монтаж да се предадат на клиента.</p> <p>За да използвате прикрито устройство на ремаркетото е необходимо едновременно да монтирате и електрическата инсталация. (Кабели не са включени)</p> <p>Махнете подложения за уплътнение антикорозионен восък и шумоизолация материал около контактите повърхности.</p> <p>Нанесете материал за защита от корозия там, където е необходимо, както е посочено в ръководството за обслужване на TOYOTA.</p> <p>След около 1000 km използване на ремаркетото, затегнете всички болтове до правилните стойности на въртящия момент.</p> <p>За правилни натоварвания на ремаркетото, моля, вижте документите на превозното средство според индивидуалния модел.</p> <p>Сферичният шарнир трябва да се пази чист и добре смазан*.</p> <p>*ИЗКЛЮЧЕНИЕ: Когато се използват стабилизатори, действайте според инструкциите на производителя на стабилизатора. В този случай сферичният шарнир трябва да се преглежда за износване на определени интервали.</p> <p>Съединителният механизъм на ремаркетото трябва да се монтира и проверява в съответствие с приложените национални разпоредби.</p>	<p><b>EST</b> TIISLI PAIGALDUSJUHISED</p> <p>Tüüp: 6238 D-väärtus: 8,5kN Vertikaalkoormus haakeseadmele: 75 kg Tootja: Brink B.V. Postbox 24 NL 7950 AA Staphorst</p> <p>Sobiv mudel: Corolla (HB) NL 7950 AA Staphorst</p> <p>EÜ tüübikinnitus nr.: E11 55R 0111085</p> <p>A50-X</p> <p>Vajalik on professionaalne paigaldus</p> <p>Veenduge, et klient saab paigaldusjuhised kätte.</p> <p>Haakeseadme kasutamiseks tuleb samaaegselt paigaldada ka elektrikomplekt. (Kaablikomplekt ei kuulu varustusel!)</p> <p>Eemaldage kokkupuutepindadelt aluskate, korrosioonivastane vaha ja müraisolatsioonimaterjal.</p> <p>Kandke vajalikesse kohtadesse korrosioonikaitse vahendit vastavalt TOYOTA hooldusjuhistele.</p> <p>Pärast ligikaudu 1000 km haagise kasutust, keerake kõik poldid uuesti õigele jõumomendile.</p> <p>Haagisele sobivaid koormusi vaadake palun vastava sõidukiimudeli dokumentidest. Jälgige, et ühenduspall oleks puhas ja märitud*.</p> <p>*ERAND: Kui kasutate stabilisaatoreid, siis jätkake vastavalt stabilisaatori tootja juhistele. Sellisel juhul peab ühenduspalli regulaarselt ajavahemike tagant kontrollima.</p> <p>Haakeseadet tuleb paigaldada ja kontrollida vastavalt kehtivale riiklikele määrustele.</p>	<p><b>LV</b> BUKSĒŠANAS STIENA IEKĀRTAS UZSTĀDĪŠANAS INSTRUKCIJA</p> <p>Tipi: 6238 Koeficients D (nosaka pēc automobiļa un autopiķekabes masas): 8,5kN Vertikālā slodze uz buksēšanas stieņa iekārtas: 75 kg Ražotājs: Brink B.V. Postbox 24 NL 7950 AA Staphorst</p> <p>Lietošanas diapazons: Corolla (HB) Eiropas Kopienas tipa atļauja Nr.: E11 55R 0111085</p> <p>A50-X</p> <p>Buksēšanas stieņa iekārtas uzstādīšana jāveic sertificētam automobiļu mehāniķim.</p> <p>Lūdzu, nodrošiniet šīs uzstādīšanas instrukcijas nodošanu klientam.</p> <p>Lai lietotu buksēšanas stieņa iekārtu, nepieciešams uzstādīt attiecīgos elektriskos komponentus. (Vadi komplektā nav iekļauti!)</p> <p>Noņemiet no kontakta virsmām nehermētisko blīvējumu, pretkorozijas vasku un trokšņus slāpējošo materiālu.</p> <p>Ja nepieciešams, apstrādājiet virsmas ar pretkorozijas materiālu, kā norādīts "TOYOTA" servisa norādēs.</p> <p>Pēc aptuveni 1000 km nobraukšanas ar autopiķekabi pārbaudiet, vai visas bultskrūves ir pievilkta līdz pareizajam griezes momentam. Lai iegūtu informāciju par autopiķekabes atļautajām slodzēm, lūdzu, skatiet attiecīgā transportlīdzekļa modeļa dokumentāciju. Savienojājai lodei jābūt tīrai un pietiekami ieeļotai.*</p> <p>*PIEZĪME: lietojot stabilizatorus, rīkojieties saskaņā ar stabilizatora ražotāja instrukciju. Regulāri pārbaudiet, vai savienojošā lode nav pārmerīgi nodilusi.</p> <p>Autopiķekabes savienojums jāizveido un jāpārbauda atbilstoši saistošajiem likuma noteikumiem.</p>	<p><b>LT</b> TVIRTINIMO INSTRUKCIJOS – TEMPIMO STRYPAS</p> <p>Tipas: 6238 D-reiškėmė: 8,5kN Vertikalaus jungimo tempimo juosta: 75 kg Vertikalaus jungimo transporto priemonė: 50 kg Gamintojas: Brink B.V. Postbox 24 NL 7950 AA Staphorst</p> <p>Naudojamos modelis: Corolla (HB) EB Tipu patvirtinimo nr.: E11 55R 0111085</p> <p>A50-X</p> <p>Reikia patyrisio tvirtintojo</p> <p>Išitikinkite, kad šios tvirtinimo instrukcijos bus pateikiamos klientui.</p> <p>Norint naudotis priekaba, kartu reikia sumontuoti ir elektros rinkinį. (Kabeliai nepridedami!)</p> <p>Nuo kontaktuojančių paviršių nuimkite apatinį sandariklio sluoksnį, antikorozinį vašką ir triukšmą šalinančią medžiagą.</p> <p>Kur reikia, uždekitė apsaugančią nuo korozijos medžiagą, kaip nurodyta „TOYOTA“ priežiūros instrukcijoje.</p> <p>Kai priekaba nuvažiuos maždaug 1000 km, iš naujo tinkamai priveržkite visus varžtus.</p> <p>Dėl tinkamos priekabos apkrovos žiūrėkite atskirų modelių dokumentus. Jungties rutulys turi būti švarus ir gerai suteptas*.</p> <p>*išimtis: jei naudojami stabilizatoriai, laikykitės stabilizatoriaus gamintojo pateiktamų instrukcijų. Šiuo atveju reikia reguliariai tikrinti, ar jungties rutulys nesusižeidęs.</p> <p>Priekabos jungtis turi būti montuojama ir apžiūrima pagal galiojančius vietinius reikalavimus.</p>

GR

Οδηγίες τοποθέτησης για αφαιρούμενο  
κοτσαδόρο

Τύπος: 6238  
D - τιμή: 8,5 kN  
Μέγ. κατακόρφο  
φορτίο ζεύξης μπάρας  
ρμμούλκησης: 75 kg  
Φατσασκευαστής: Brink B. V.  
Postbox 24,  
NL 7950 AA Staphorst  
Τομέας εφαρμογής: Corolla (HB)  
EOK-έγκριση τύπου αρ.: E11 55R 0111085

A50-X

Η τοποθέτηση εκτελείται σε ένα ειδικό  
συνεργείο

Οι οδηγίες τοποθέτησης αυτές παραδίδο-  
νται στον πελάτη.

Για τη λειτουργία του κοτσαδόρου είναι απα-  
ραίτητη η ταυτόχρονη τοποθέτηση ενός κιτ  
ηλεκτρικής τροφοδοσίας. (Δεν συμπαράδιδε-  
ται σετ καλωδίων!)

Στην περιοχή των επιφανειών εφαρμογής  
πρέπει να αφαιρεθεί η προστασία σασί, η  
συντήρηση κενών χώρων (κηρός) και το αντι-  
δομητικό υλικό.

Εκεί, όπου είναι απαραίτητο, προστατεύετε  
έναντι διάβρωσης σύμφωνα με τις οδηγίες  
του TOYOTA-σέρβις.

Μετά από 1000 χιλιόμετρα διαδρομής με  
ρμμούλκόμενο φορτίο σφίγγετε πάλι όλες τις  
βίδες στερέωσης με την προκαθορισμένη  
ροπή περιστροφής.

Ενημερωθείτε για το επιτρεπόμενο ορτίο  
ρμμούλκησης για το εκάστοτε μοντέλο οχήμα-  
τος από τα χαρτιά του οχήματός σας.

Ο κοτσαδόρος πρέπει να διατηρείται καθαρός  
και να λιπαίνεται\*.

\*ΕΞΑΙΡΕΣΗ: Σε περίπτωση χρήσης διατάξεων  
σταθεροποίησης, οι οποίες δρουν  
επάνω στον κοτσαδόρο, ενεργείτε  
σύμφωνα με τις υποδείξεις του  
κατασκευαστή των διατάξεων  
σταθεροποίησης. Επίσης πρέπει  
σε περίπτωση μιας τέτοιας διάτα-  
ξης σταθεροποίησης ο κοτσαδό-  
ρος να ελέγχεται σε τακτά διαστή-  
ματα για πιθανές φθορές.

Η τοποθέτηση, ο έλεγχος και η χορήγηση  
άδειας λειτουρ-γίας του κοτσαδόρου  
πρέπει να διεξάγονται σύμφωνα  
με τις ισχύουσες νομοθετικές διατάξεις.

SLV

NAVODILO ZA MONTAŽO – VLEČNA KLJUKA

Vrsta: 6238  
D-vrednost: 8,5 kN  
Spajna sila vlečne kljuke  
v navpični smeri: 75 kg  
Proizvajalec: Brink B. V.  
Postbox 24  
NL 7950 AA  
Staphorst  
Področje uporabe: Corolla (HB)  
Št. ES-homologacije: E11 55R 0111085

A50-X

Montažo vlečne kljuke naj opravijo ustrezno  
usposobljeni serviserji  
Kupec mora prejeti ta navodila za montažo.

Za uporabo vlečne kljuke morate hkrati vgraditi  
tudi ustrezno električno instalacijo. (kabelski  
komplet ni priložen)

Na naležnih površinah odstranite talno zaščito,  
vosek za zaščito proti koroziji in material  
zvočne izolacije.

Material za zaščito proti koroziji nanesite na  
predvidena mesta v skladu s TOYOTA smerni-  
cami za servisiranje.

Po pribl. 1000 prevoženih km s prikolico znova  
trdno privijte vijake s predpisanim navorom.  
Podatke o nosilnosti prikolice boste našli v  
dokumentaciji vozil posameznih modelov.  
Naležna krogla mora biti čista in zadostno  
namazana\*.

\*IZJEMA: Če uporabljate stabilizatorje,











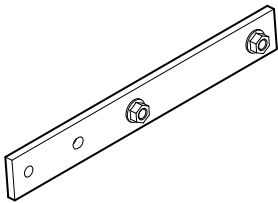
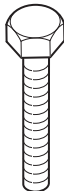

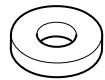
postopajte v skladu z navodili nji-  
hovega proizvajalca. V tem primeru  
je nalezno kroglo treba v rednih  
časovnih intervalih preverjati glede  
obrade.

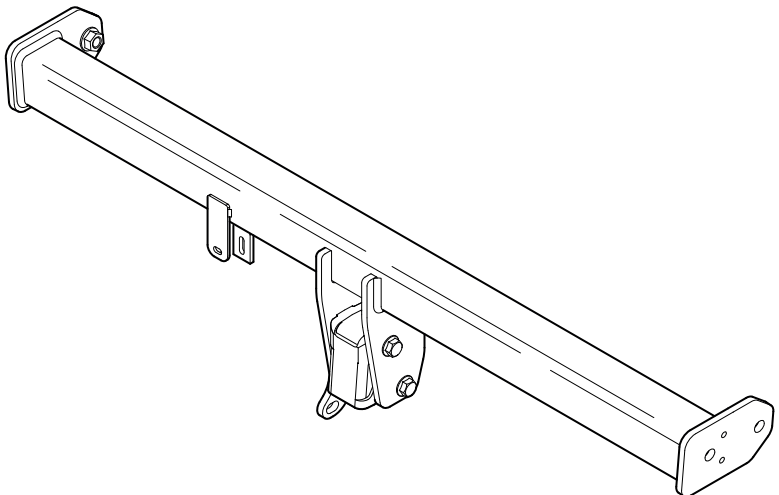
Vlečno kljuko za vozilo je treba montirati in  
preveriti v skladu z veljavnimi državnimi pred-  
pisi.

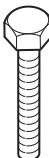

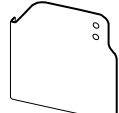
# Revision record

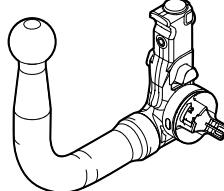

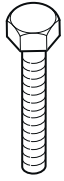

Rev. No.	Date	Page	Step	Remarks
△ <sub>1</sub>	05.04.2019	27-28	CS	Lay-out update

## PW960-02004

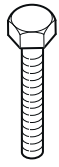
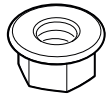
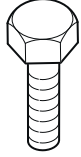
 <p><b>A</b> 2x</p>	<p>M12X40 (10.9)</p>  <p><b>B</b> 8x</p>	 <p><b>C</b> 8x</p>	 <p><b>D</b> 4x</p>		
 <p><b>E</b> 2x</p>	 <p><b>F</b> 1x</p>				
 <p><b>G</b> 1x</p>					
<p>M6X30 (8.8)</p>  <p><b>H</b> 2x</p>					
 <p><b>I</b> 1x</p>	 <p><b>J</b> 1x</p>	<p>M6</p>  <p><b>K</b> 2x</p>	 <p><b>L</b> 1x</p>	 <p><b>M</b> 1x</p>	 <p><b>N</b> 1x</p>

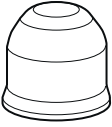
# PW960-02010

<b>B</b> M12X40 (10.9)	<b>C</b>	<b>D</b>	<b>H</b> M6X30 (8.8)	<b>K</b> M6	M12X22
					
8x	8x	4x	2x	2x	4x

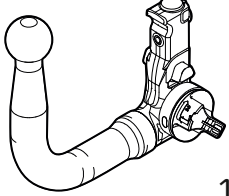
<b>PZ408-90550-01</b>	<b>PW960-02014</b>	<b>PW960-02011</b>		
<b>M</b>	<b>N</b>			<b>L</b>
				
1x	1x	1x	1x	1x

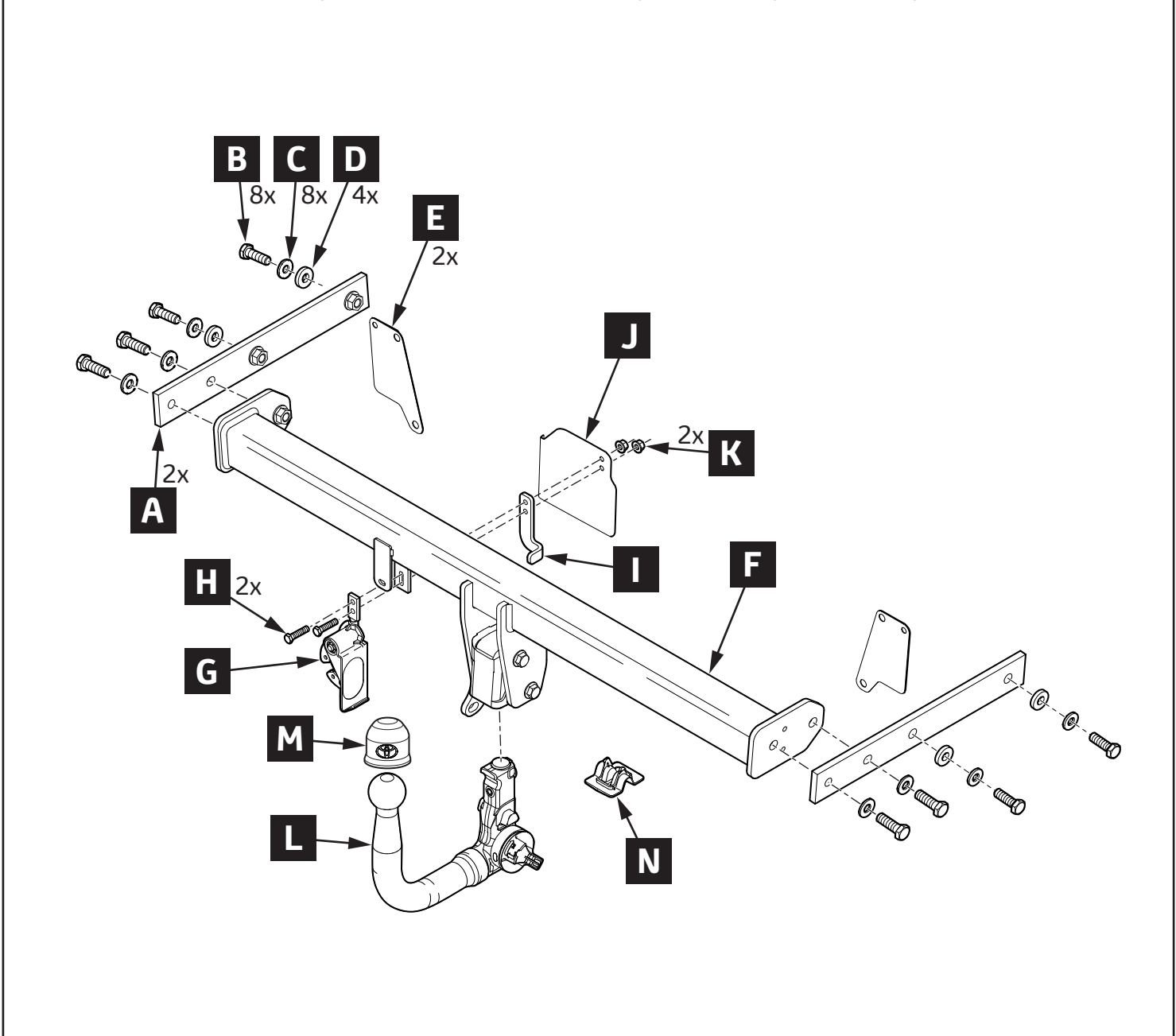

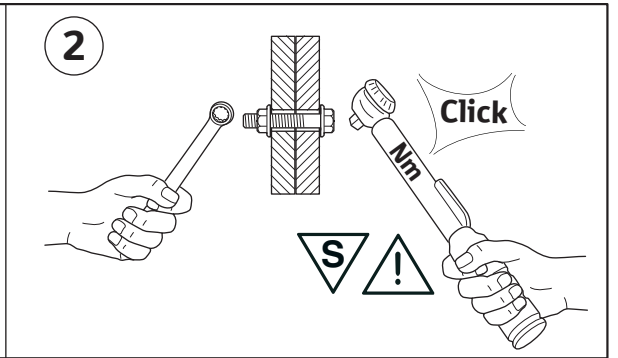
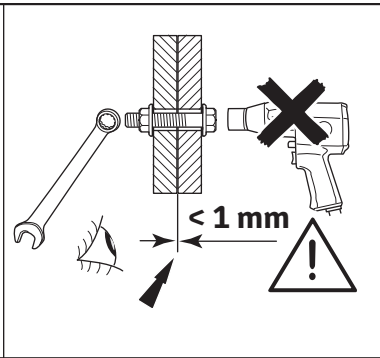
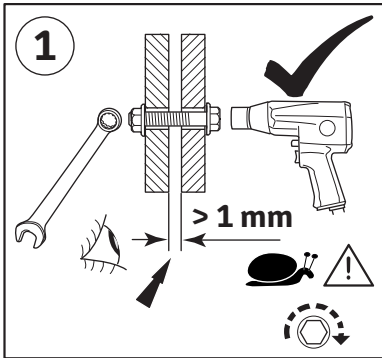
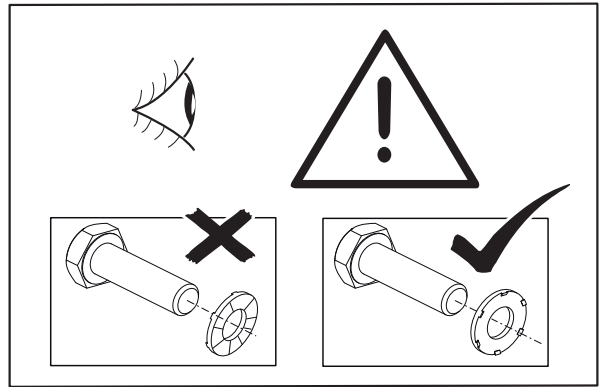
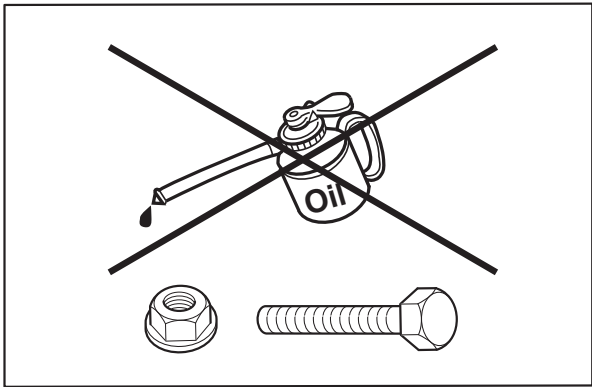











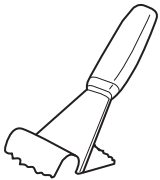



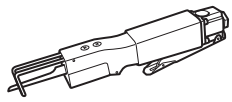
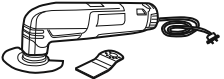
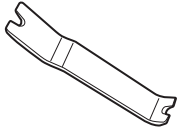

**Material Safety Data Sheet**

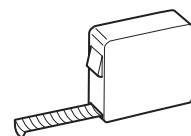

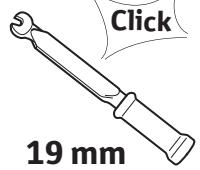

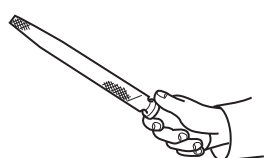

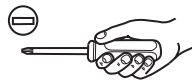









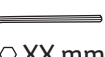









**Technical Data Sheet**





			0892-071 WURTH 	 AIM 003-516-*	 
		 19 mm			  19 mm
			10mm 12mm 17mm 19mm		10mm 12mm 17mm 19mm
					

 =  XX mm	 = 	 = 
 =  XX mm	 = 	  = 
 = 	 = 	  = 
 =  TXX	 = 	 = START

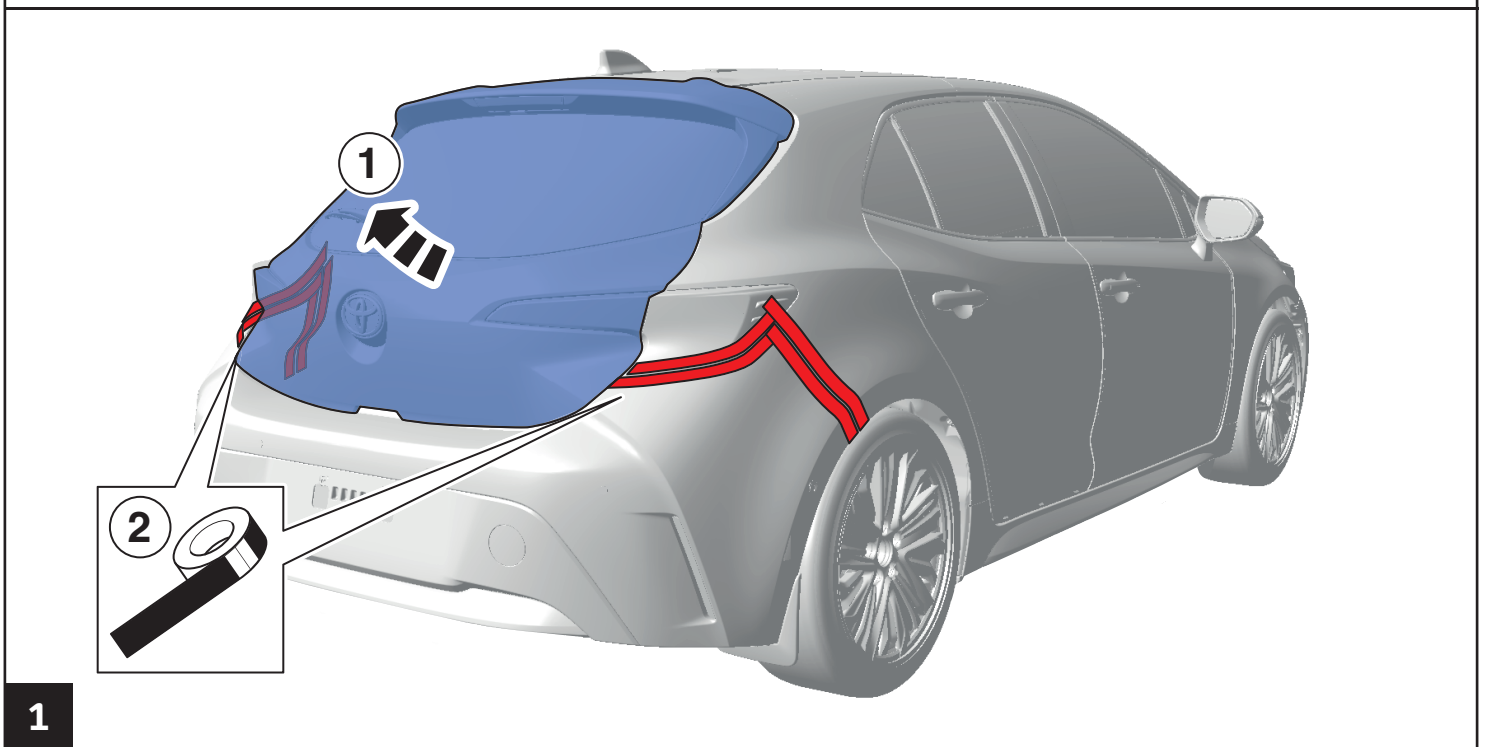

1

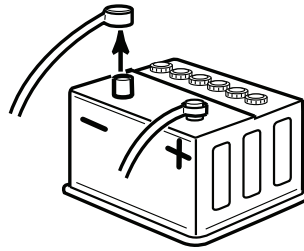
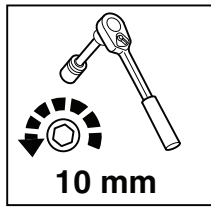

2

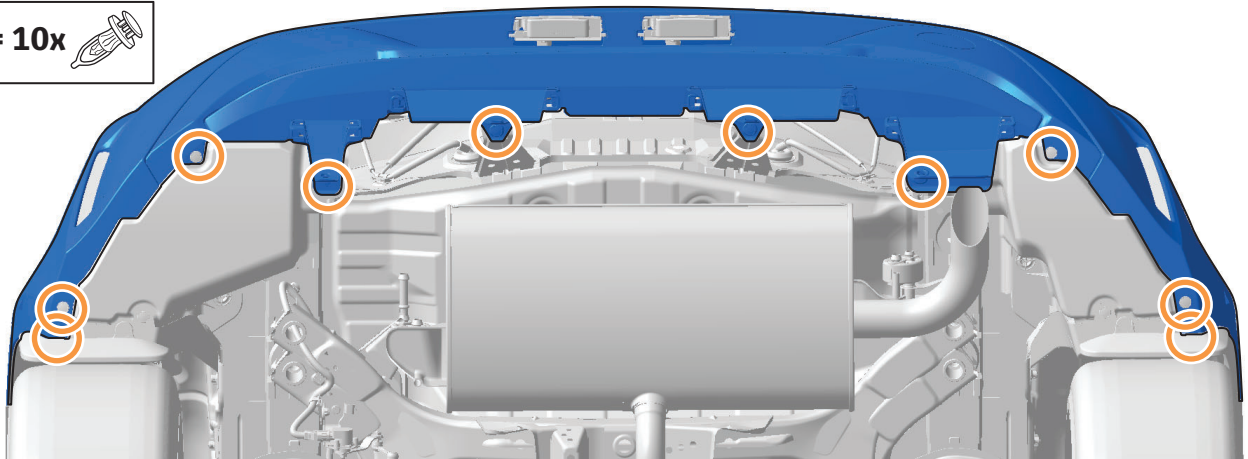
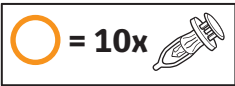

3

LHS=RHS



4

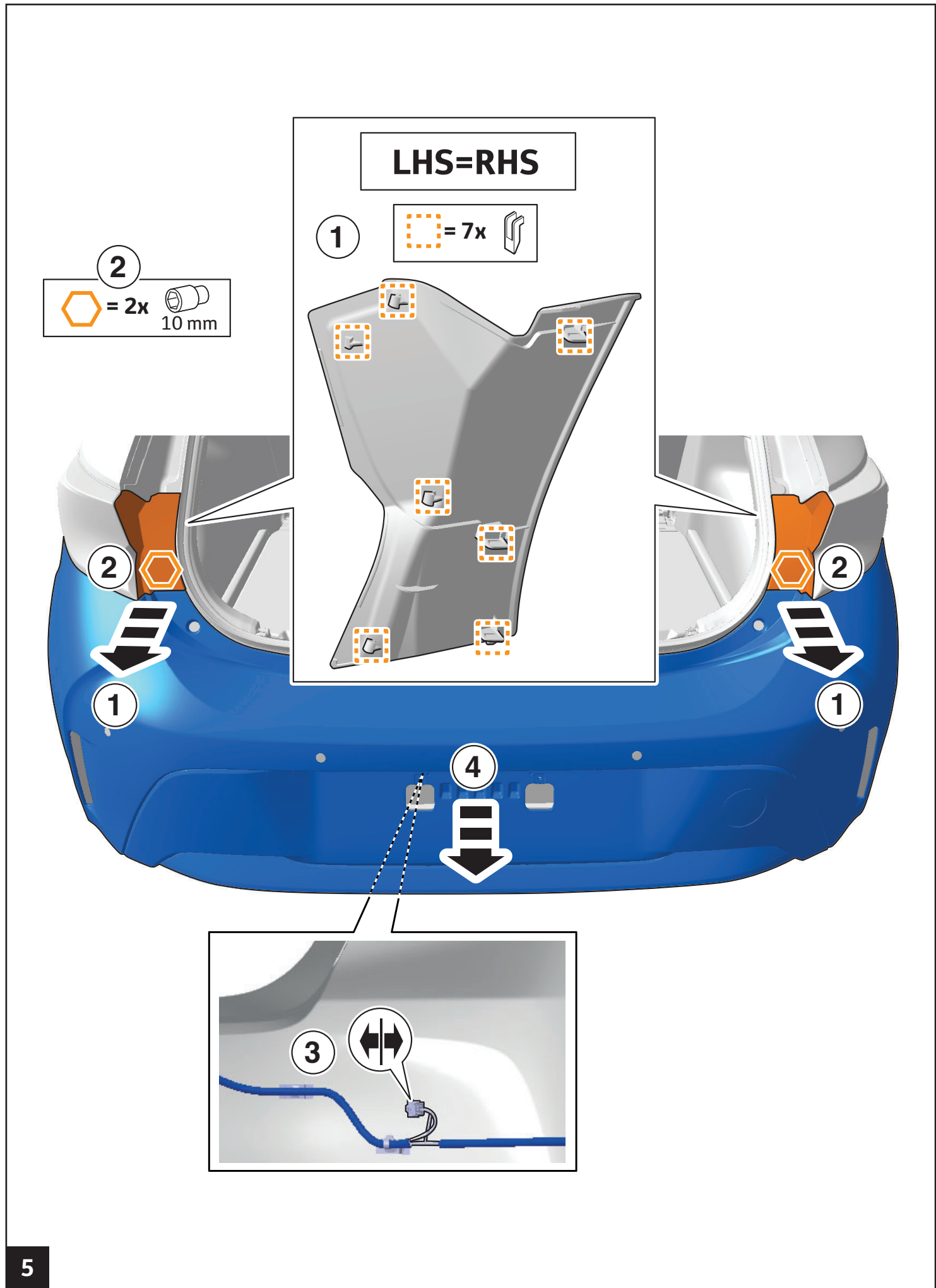

5

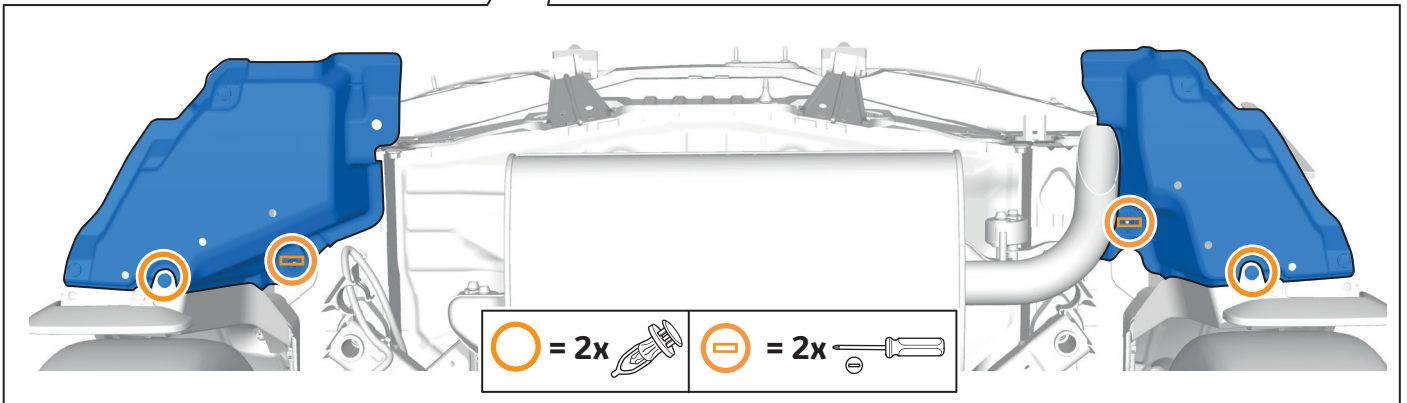
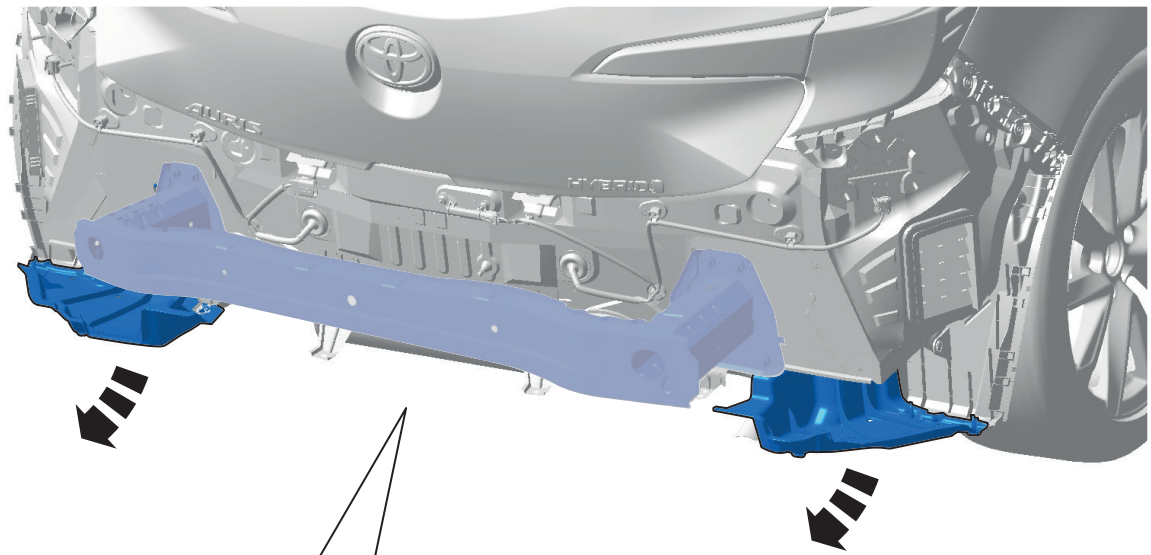

6

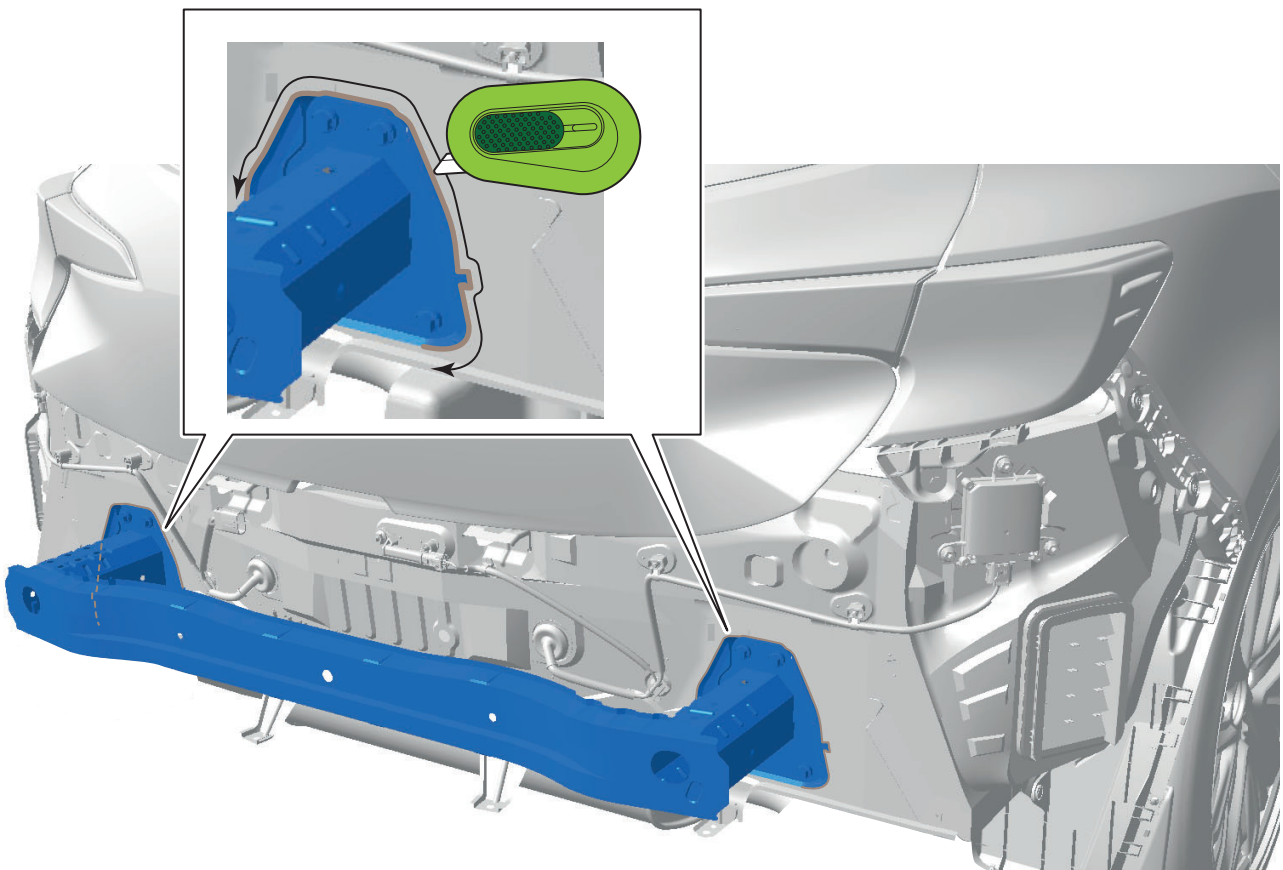

7

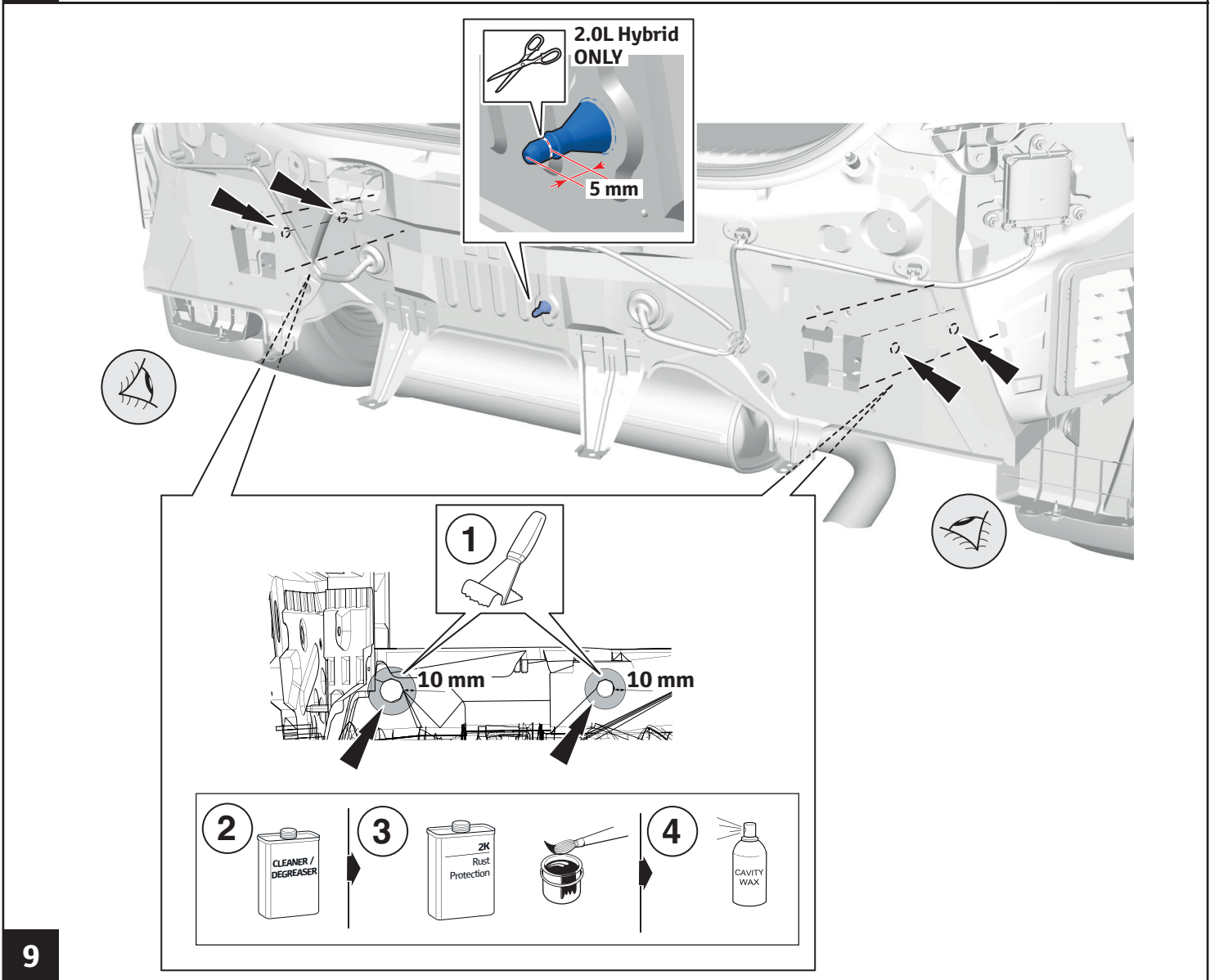
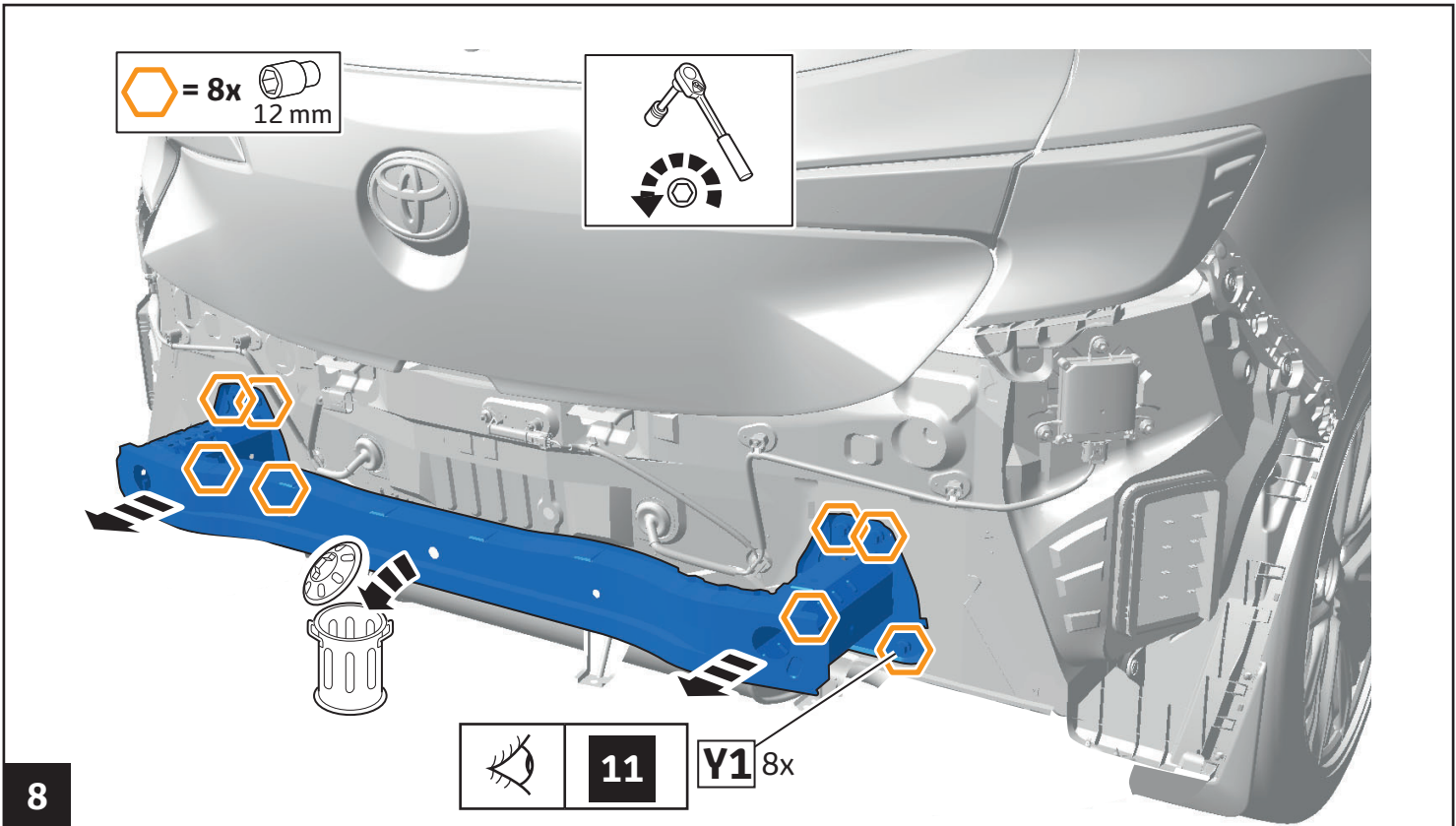

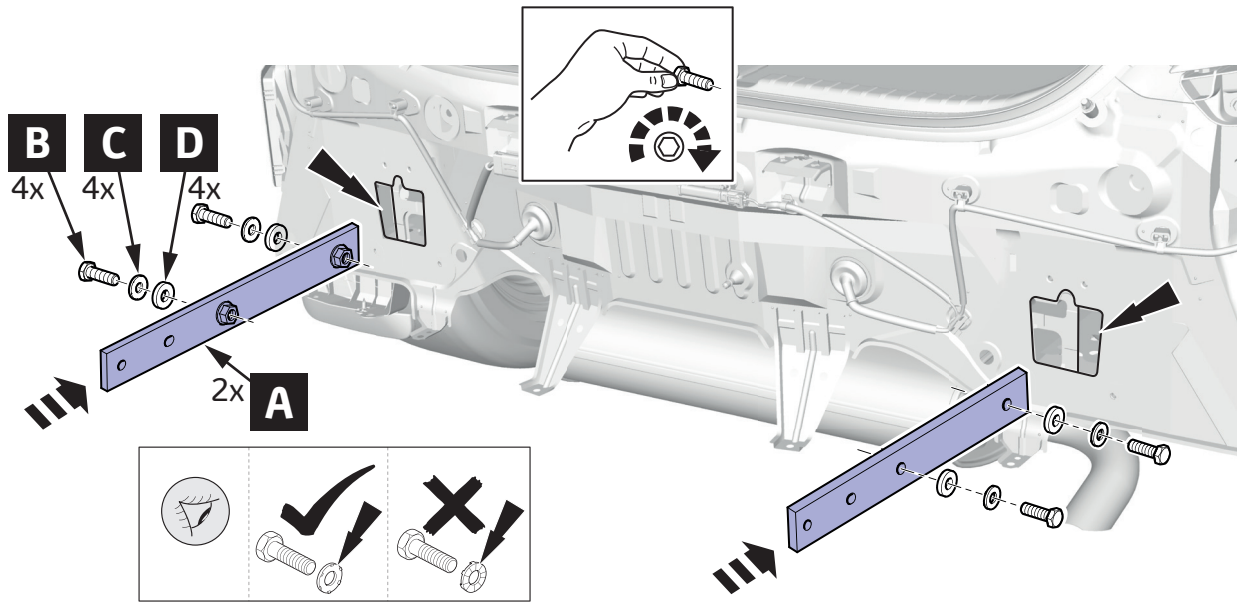

10

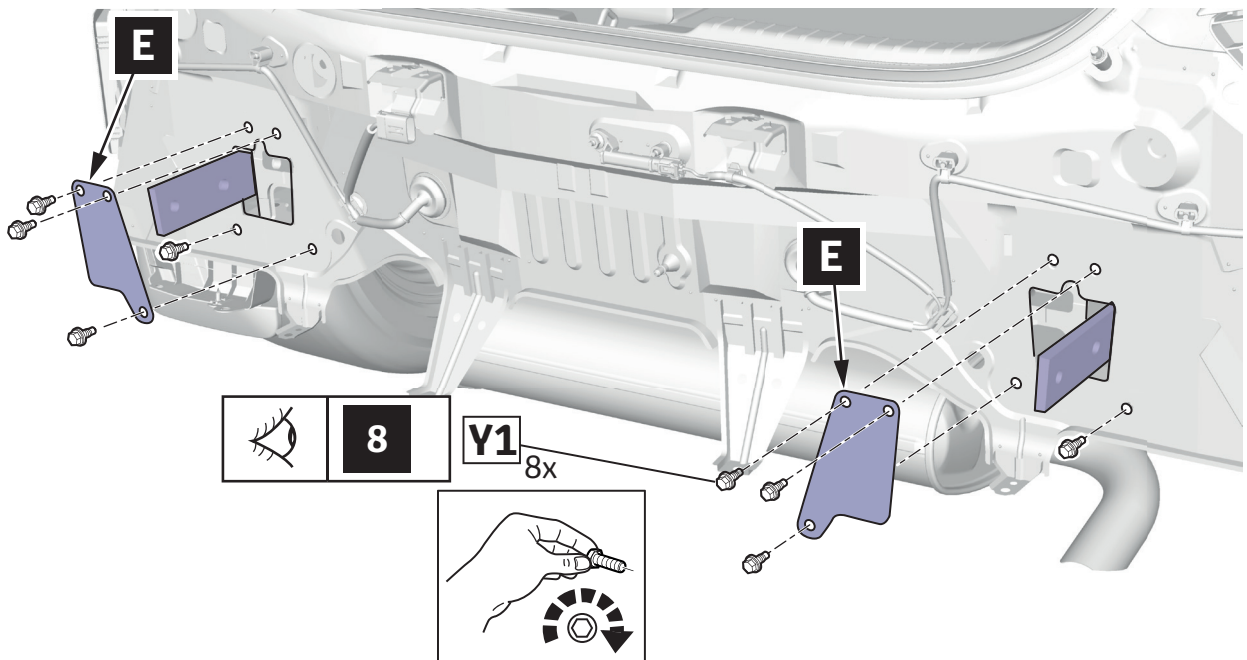



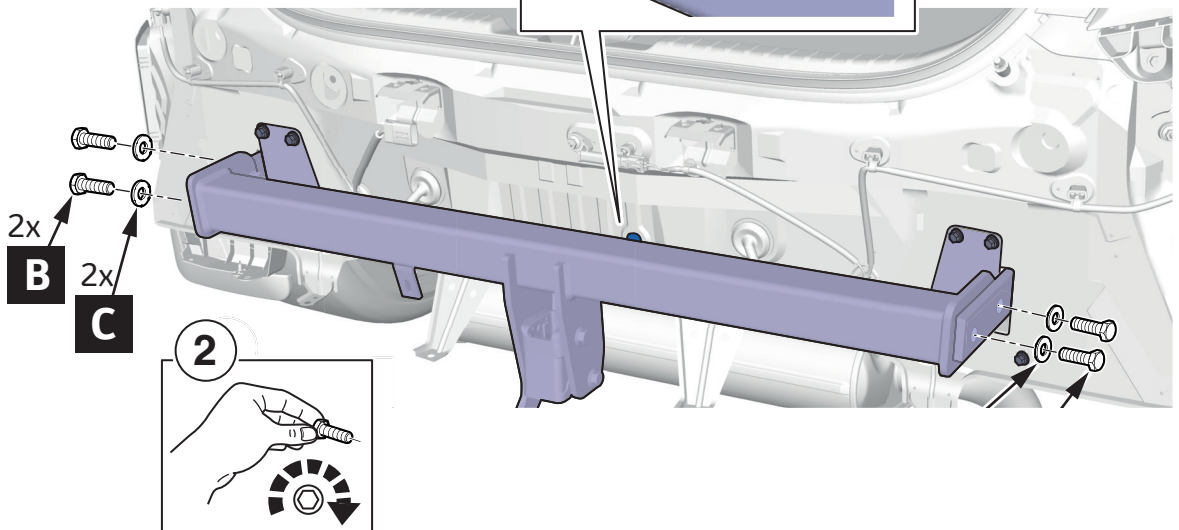
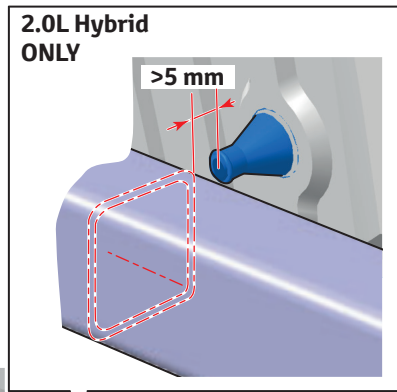
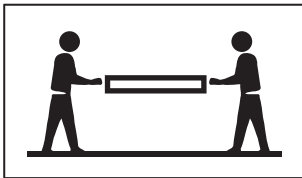
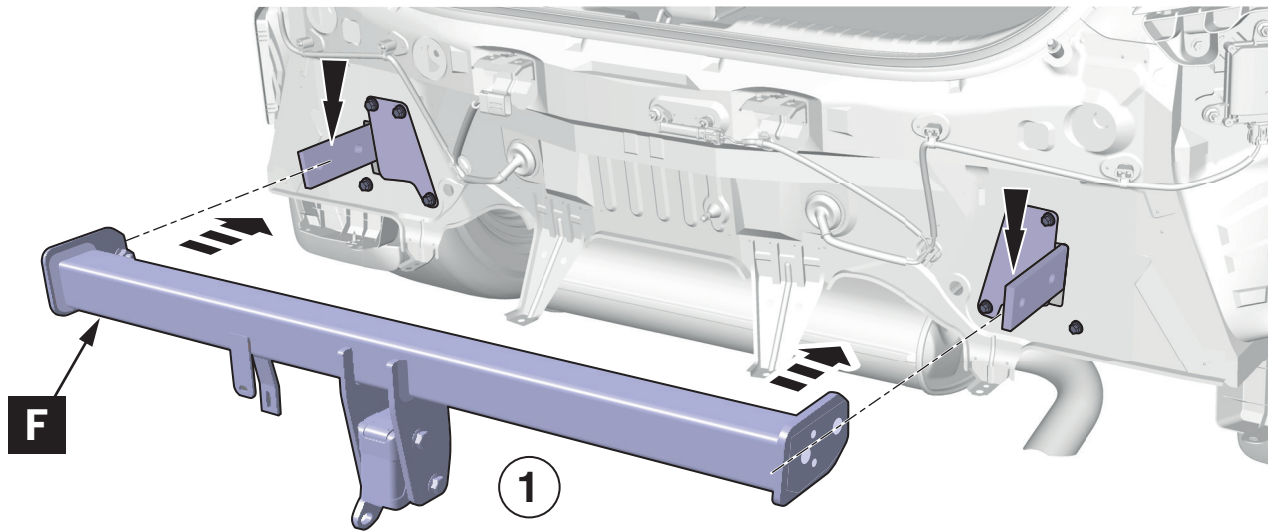

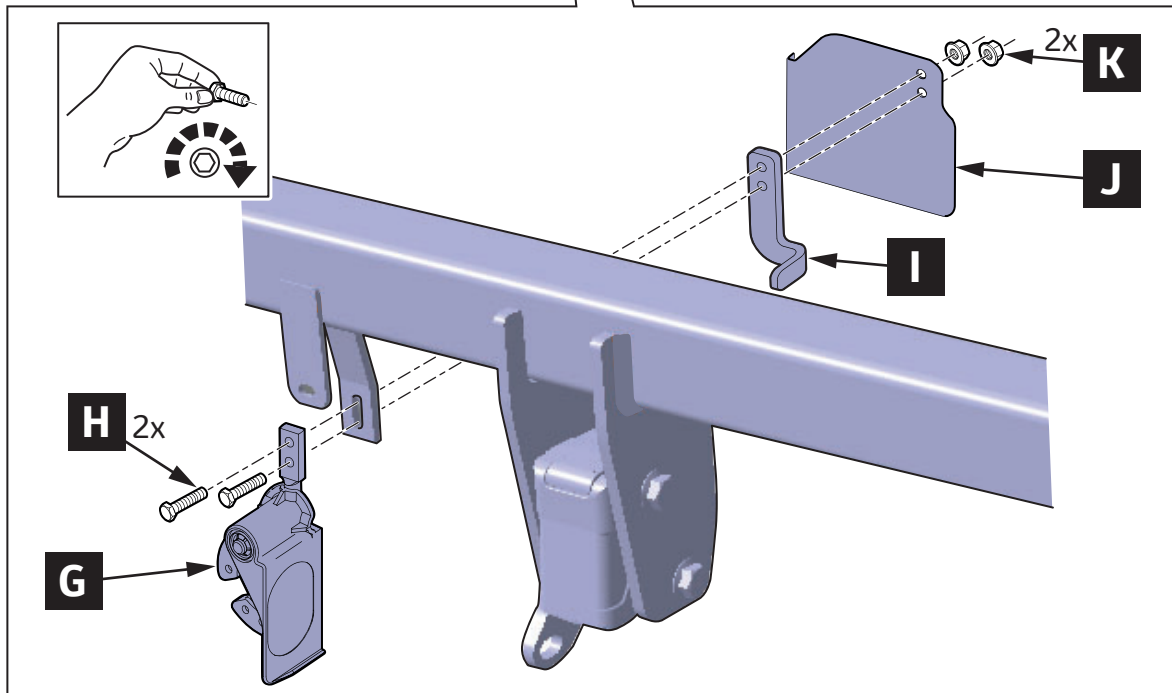
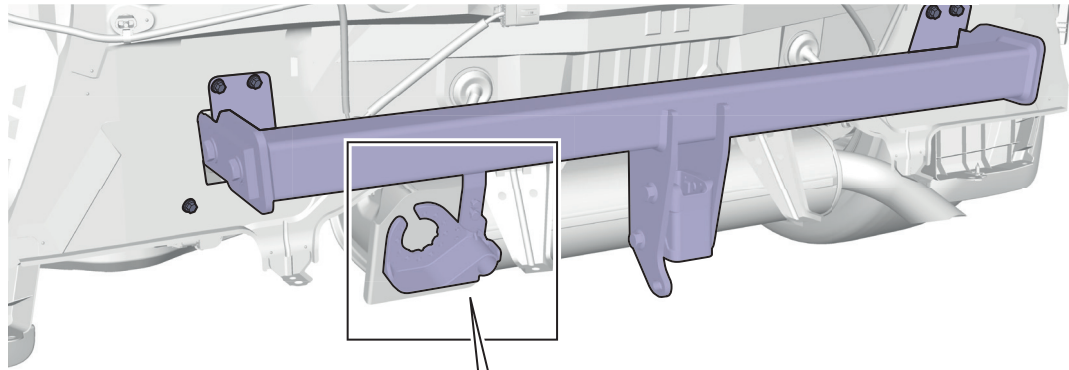

11

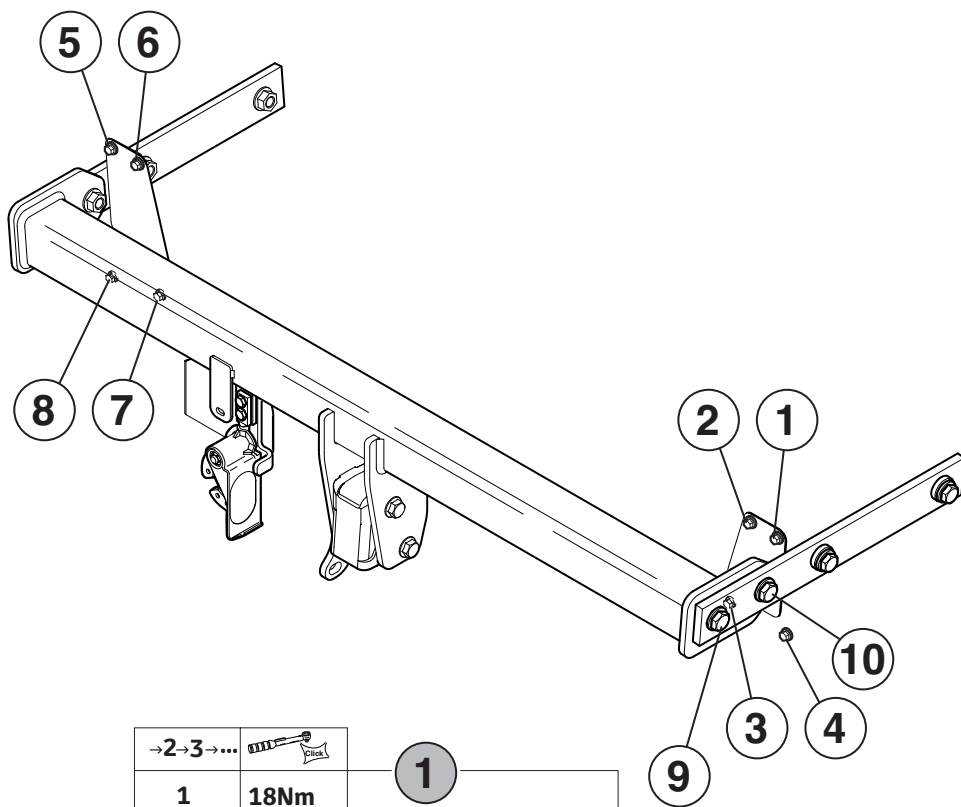









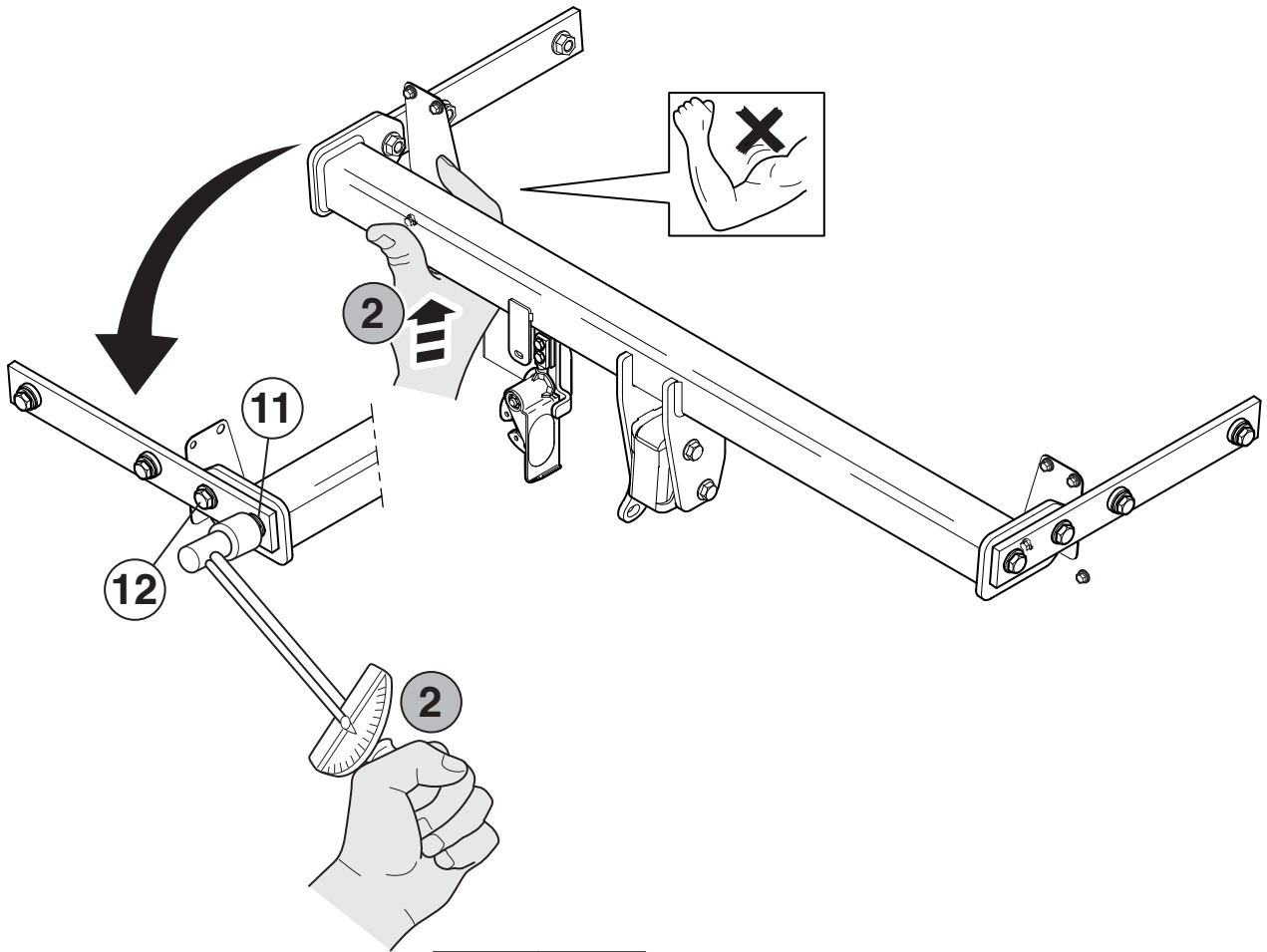



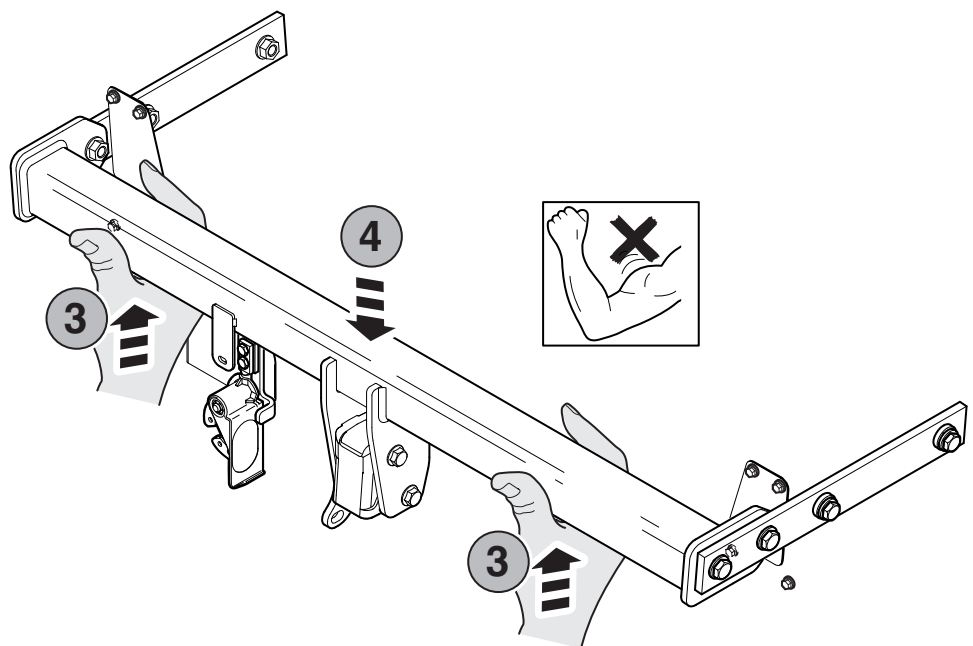

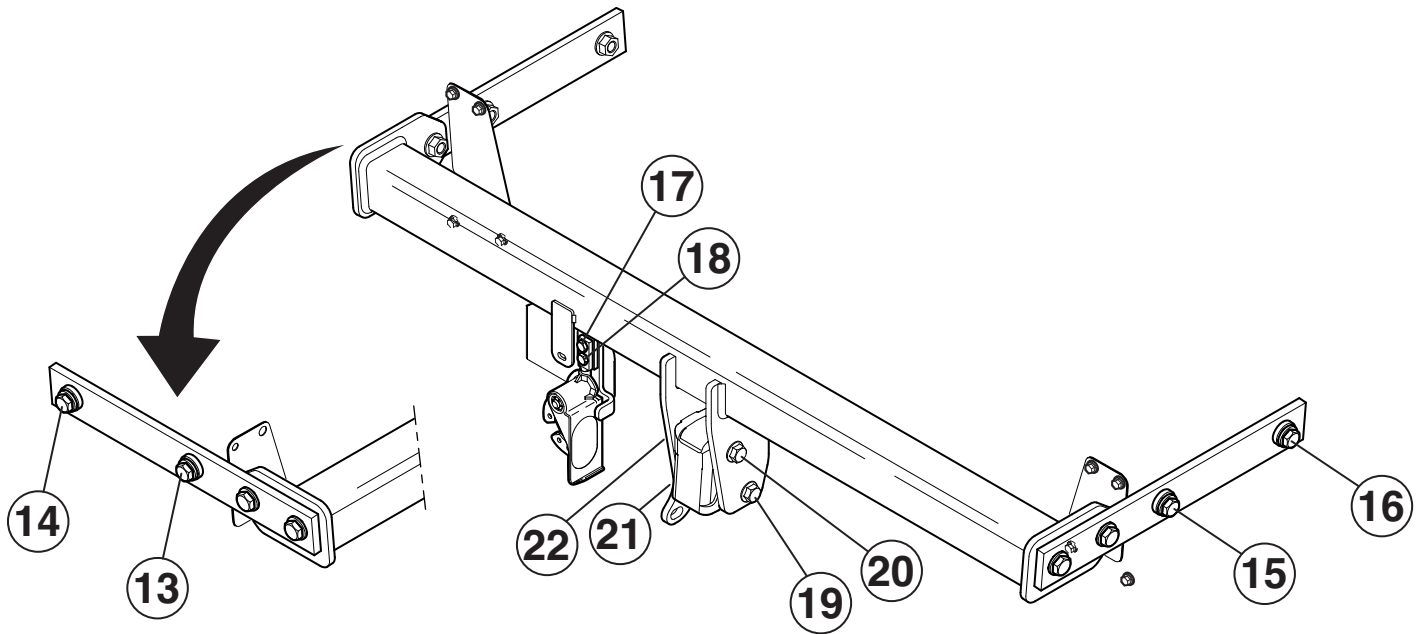



		→2→3→... 	
	<b>1</b>	<b>18Nm</b>	 <b>12mm</b>
	<b>2</b>	<b>18Nm</b>	
	<b>3</b>	<b>18Nm</b>	
	<b>4</b>	<b>18Nm</b>	
	<b>5</b>	<b>18Nm</b>	
	<b>6</b>	<b>18Nm</b>	
	<b>7</b>	<b>18Nm</b>	
	<b>8</b>	<b>18Nm</b>	
	<b>9</b>	<b>100Nm</b>	 <b>19mm</b>
	<b>10</b>	<b>100Nm</b>	



	→2→3→...		
	11	100Nm	2
	12	100Nm	19mm





		→2→3→... 		5
	13	100Nm		
	14	100Nm		19mm
	15	100Nm		
	16	100Nm		
	17	11Nm		10mm
	18	11Nm		
	19 (Only for repair)	160Nm		17mm
	20 (Only for repair)	160Nm		
	21 (Only for repair)	160Nm		
	22 (Only for repair)	160Nm		

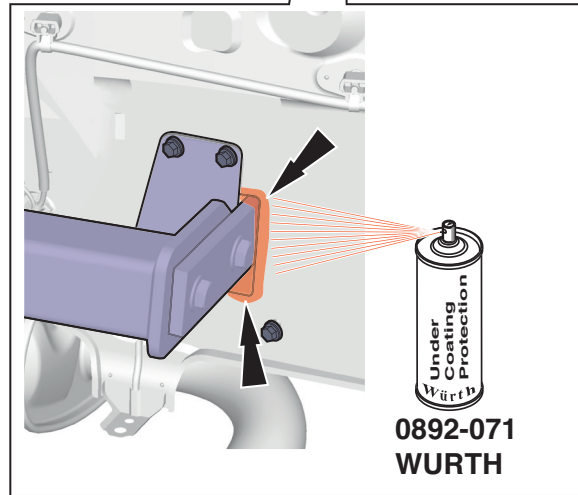
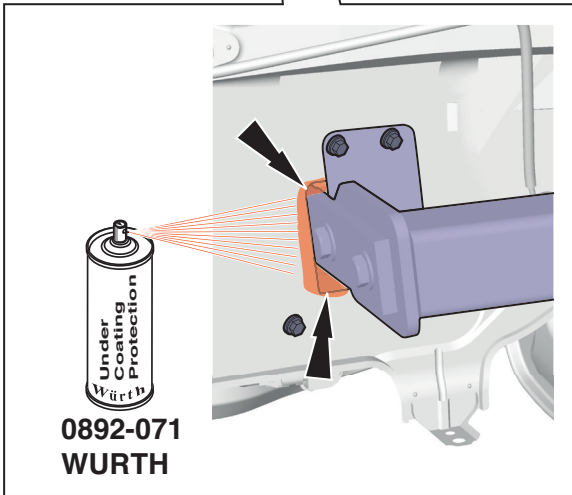
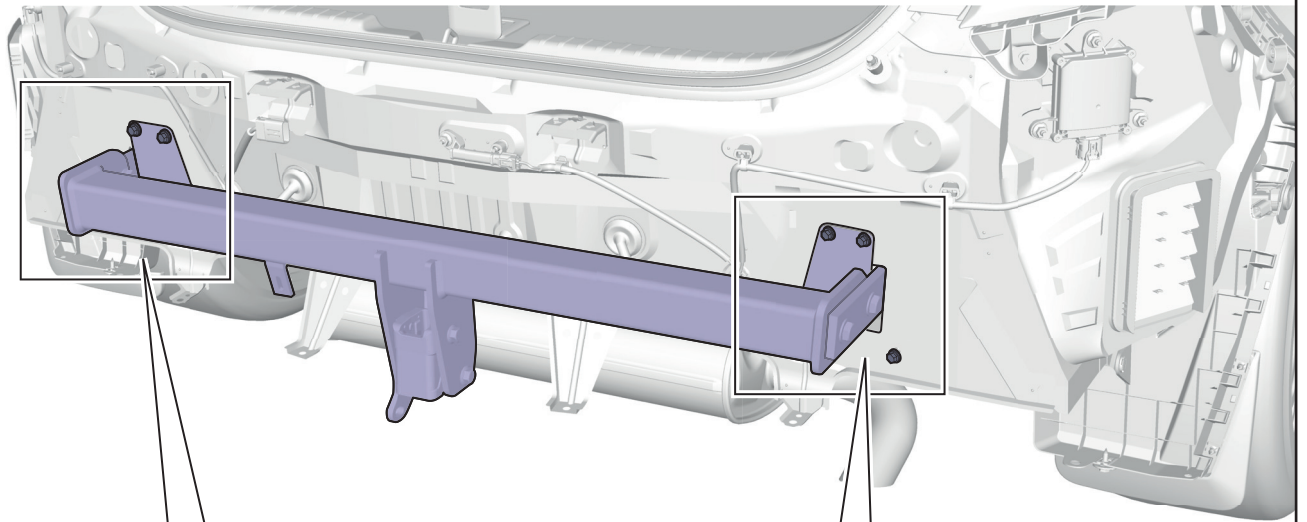

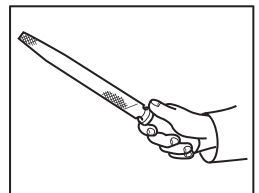
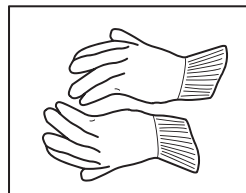
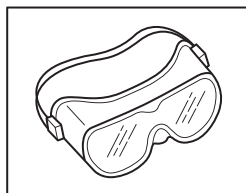
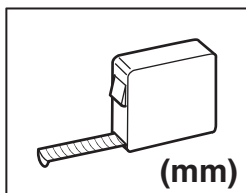
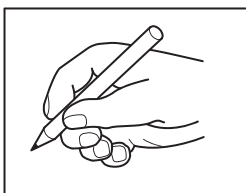
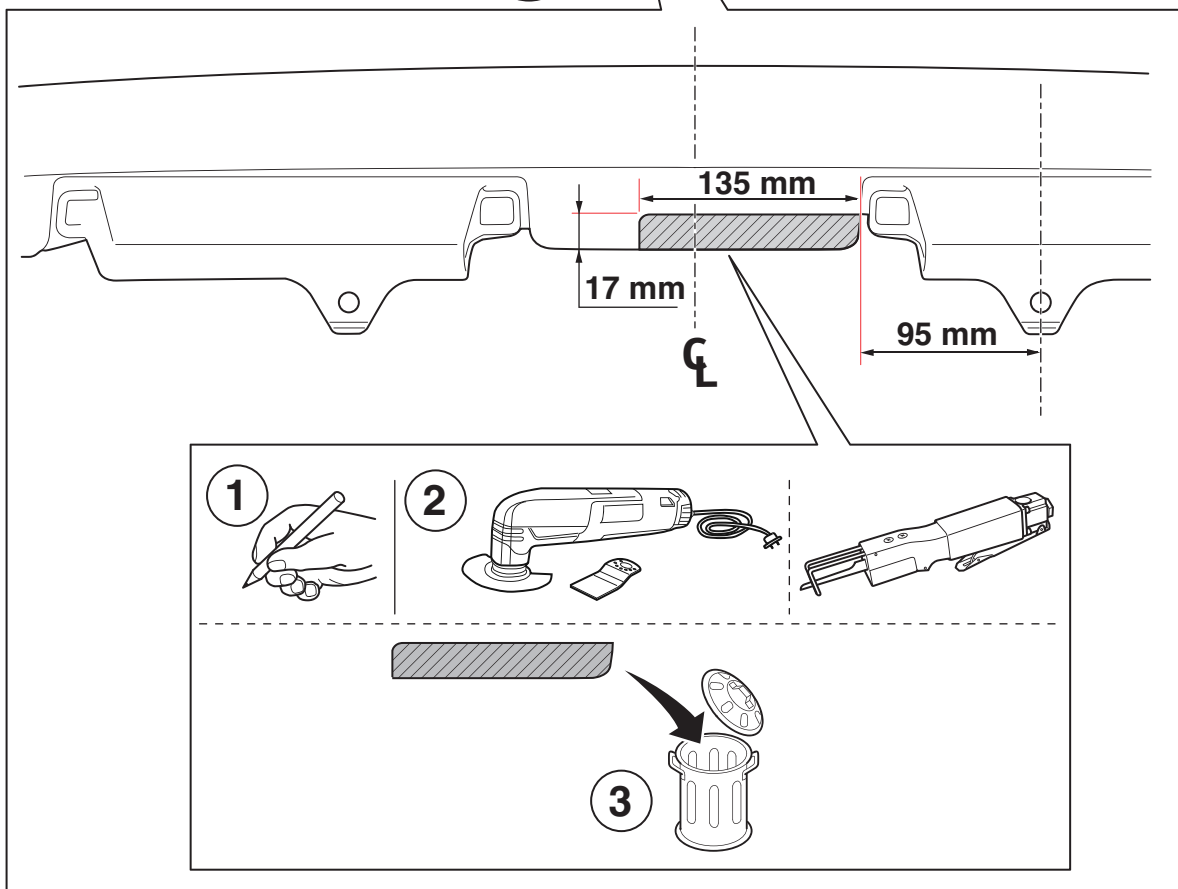
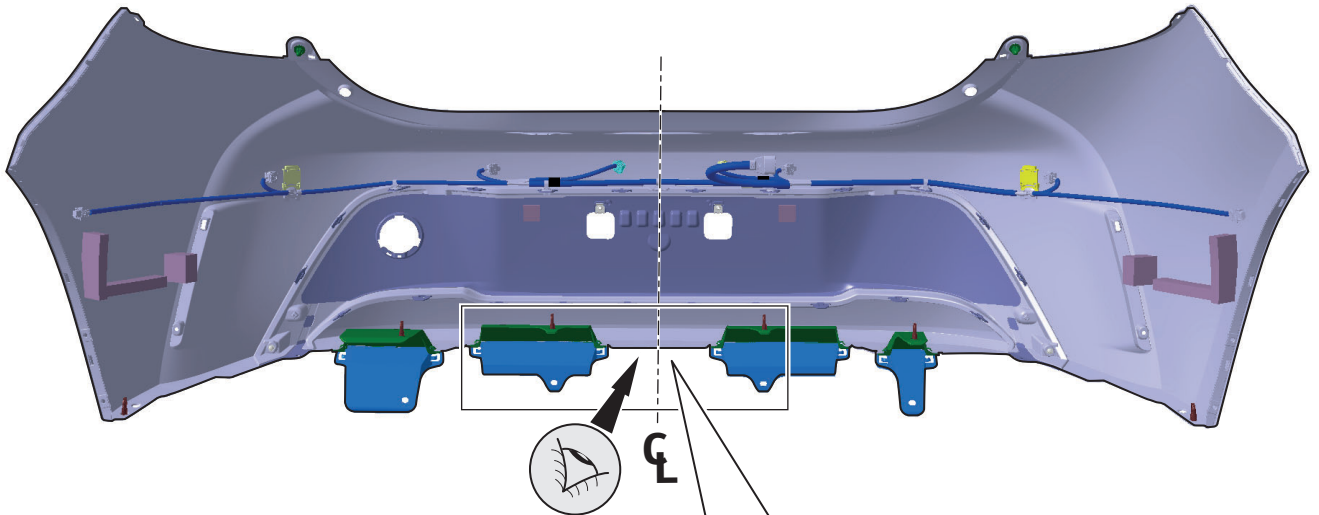

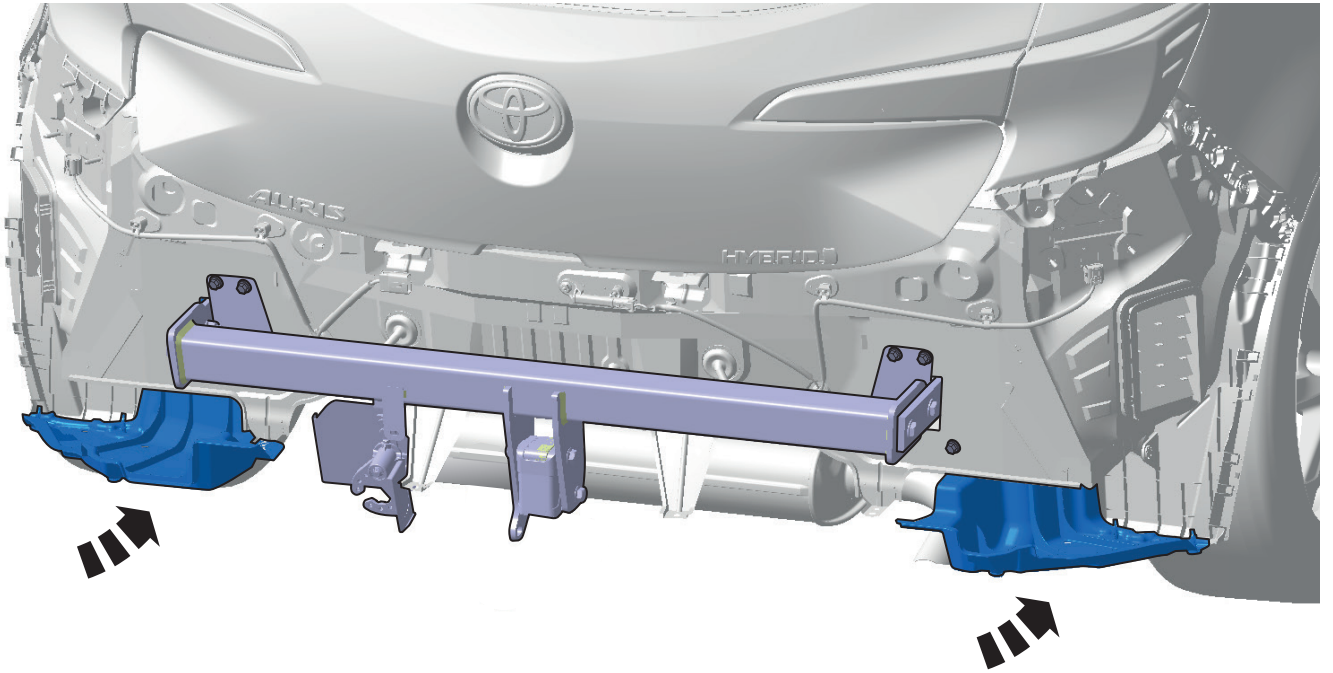

19

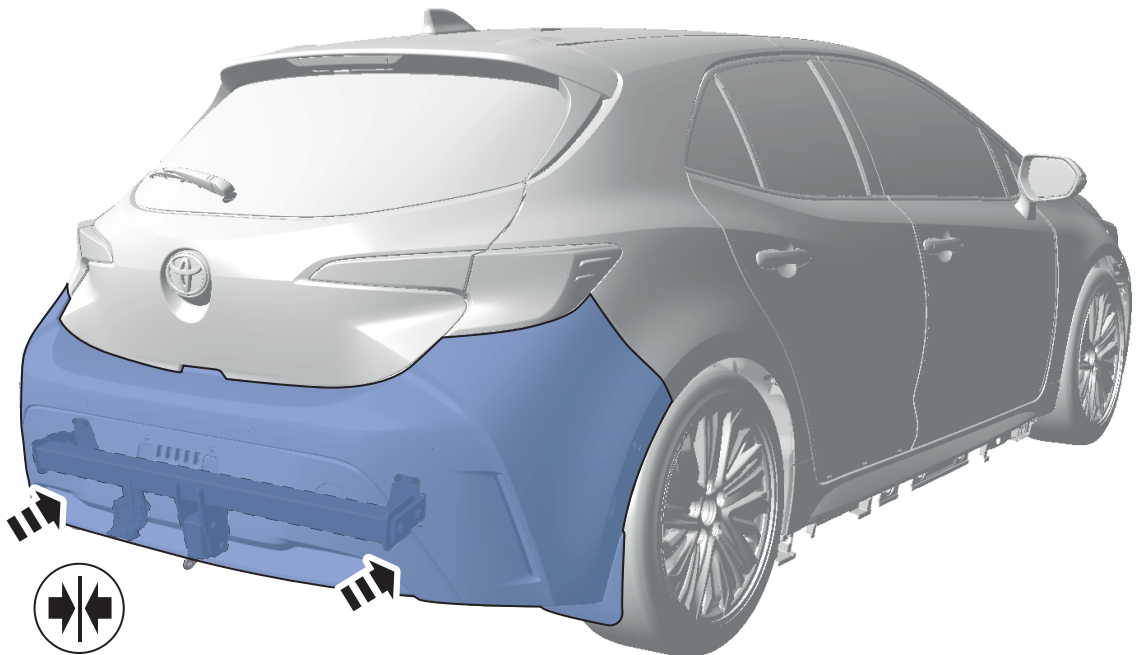

20

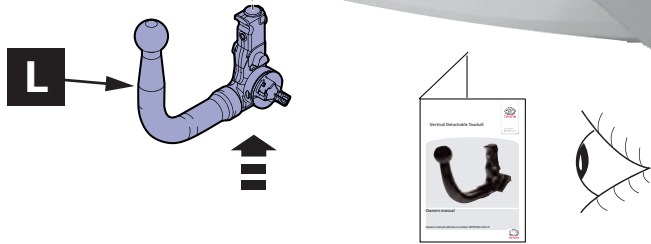
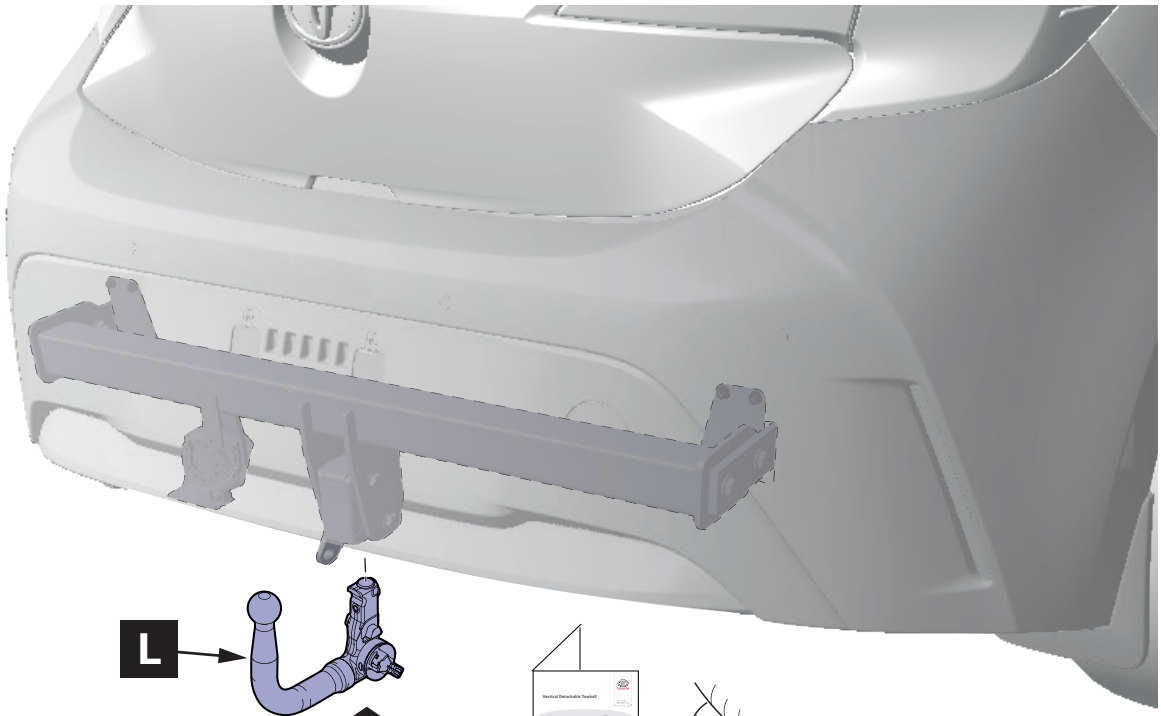

21

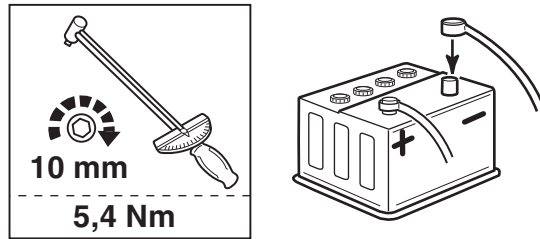

22

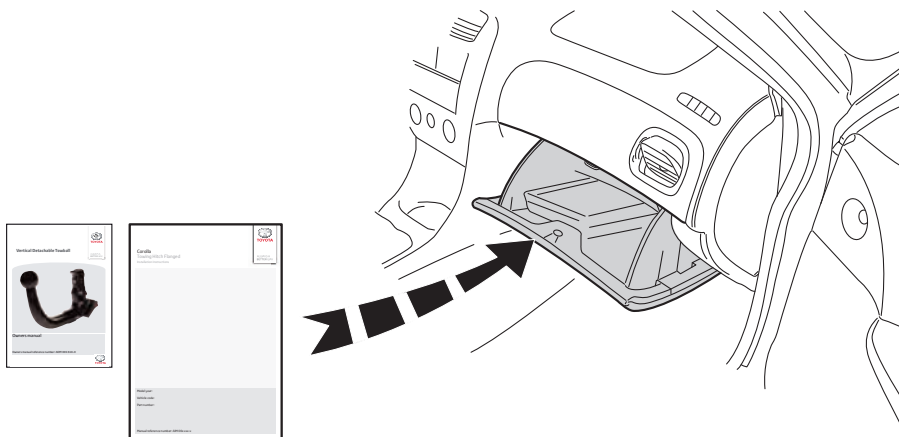

23

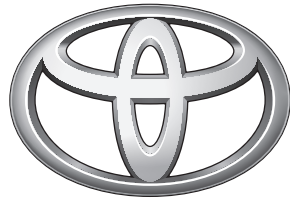

**TOYOTA**



Dispositivo di traino tipo: PZW960-02004  
Per autoveicoli: Corolla (HB) 2019/01  
Tipo funzionale: \*\*E\*1 \*\*\_DH\*\*\*\*

Classe e tipo di attacco: A50X  
Omologazione: e11 55R0111085  
Valore D: 8.5 kN  
Carico Verticale max. S: 75 kg  
Larghezza rimorchiabile per Caravan e T.A.T.S.: 2,45m vedere CARTA di CIRCOLAZIONE VEICOLO (motrice) + 70 cm = ..arrotondare ai 5 cm  
Massa rimorchiabile: superiore (vedi D.M.28/05/85)  
vedi carta di circolazione dell' autoveicolo

**Per verificare l'idoneità del dispositivo di traino omologato a norma CEE 94/20, all'installazione sulla vettura su cui si intende procedere al montaggio, compilare la seguente formula (se necessario declassare la massa rimorchiabile):**

$$D = \frac{T \times C}{T + C} \times 0,00 \geq 15,8 \text{ kN} \quad \text{..kN}$$

dove: T= Massa Complessiva Max. della motrice (in kg)  
C= Massa Rimorchiabile Max. della motrice (in kg)

## DA COMPILARE PER IL COLLAUDO

**DICHIARAZIONE DI CORRETTO MONTAGGIO:** la sottoscritta Ditta dichiara di aver montato in maniera corretta ed in conformità alle prescrizioni sia del costruttore del veicolo che del costruttore del dispositivo stesso il seguente dispositivo di attacco meccanico:

tipo:.....  
Il dispositivo di attacco sopra indicato è stato installato su autoveicolo  
modello:.....  
targa:.....  
Data:.....

**TIMBRO e FIRMA**

**Si dichiara inoltre di aver informato l'utente del veicolo sull'USO e MANUTENZIONE del dispositivo stesso.**

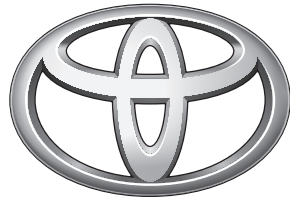

**TOYOTA**



**TOYOTA**

Model/Year Corolla (HB) 2019/01

**Towing hitch  
vertical detachable**

VIN n°

ALWAYS A  
BETTER WAY

## DURING INSTALLATION

**1**

P/N = OK



=A



=B

**2**

	1-2-3-...		A	B	Serial Number
	1	18Nm			
	2	18Nm	<input type="checkbox"/>		<input type="text"/>
	3	18Nm			
	4	18Nm			
	5	18Nm			
	6	18Nm	<input type="checkbox"/>		<input type="text"/>
	7	18Nm			
	8	18Nm			
	9	100Nm	<input type="checkbox"/>	<input type="checkbox"/>	<input type="text"/>
	10	100Nm			
	11	100Nm	<input type="checkbox"/>	<input type="checkbox"/>	<input type="text"/>
	12	100Nm			
	13	100Nm	<input type="checkbox"/>	<input type="checkbox"/>	<input type="text"/>
	14	100Nm			
	15	100Nm	<input type="checkbox"/>	<input type="checkbox"/>	<input type="text"/>
	16	100Nm			
	17	11Nm	<input type="checkbox"/>		<input type="text"/>
	18	11Nm			
	19 (Only for repair)	160Nm			
	20 (Only for repair)	160Nm	<input type="checkbox"/>	<input type="checkbox"/>	<input type="text"/>
	21 (Only for repair)	160Nm			
	22 (Only for repair)	160Nm			



**1**



5,4 Nm

**Serial Number**

**2**

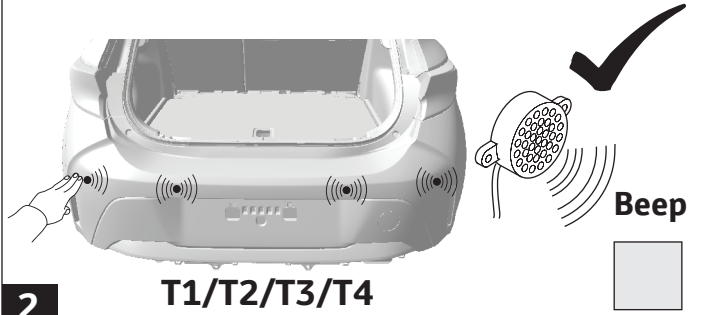

T1/T2/T3/T4

**3**

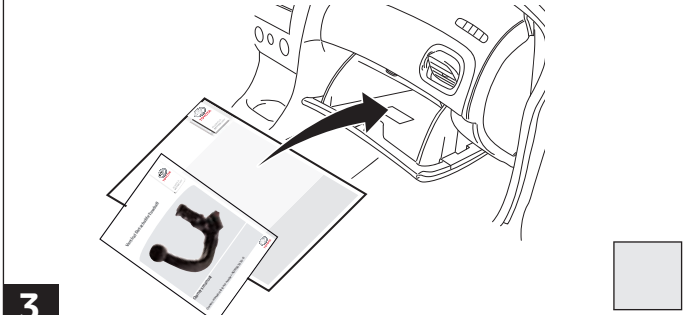

**4**

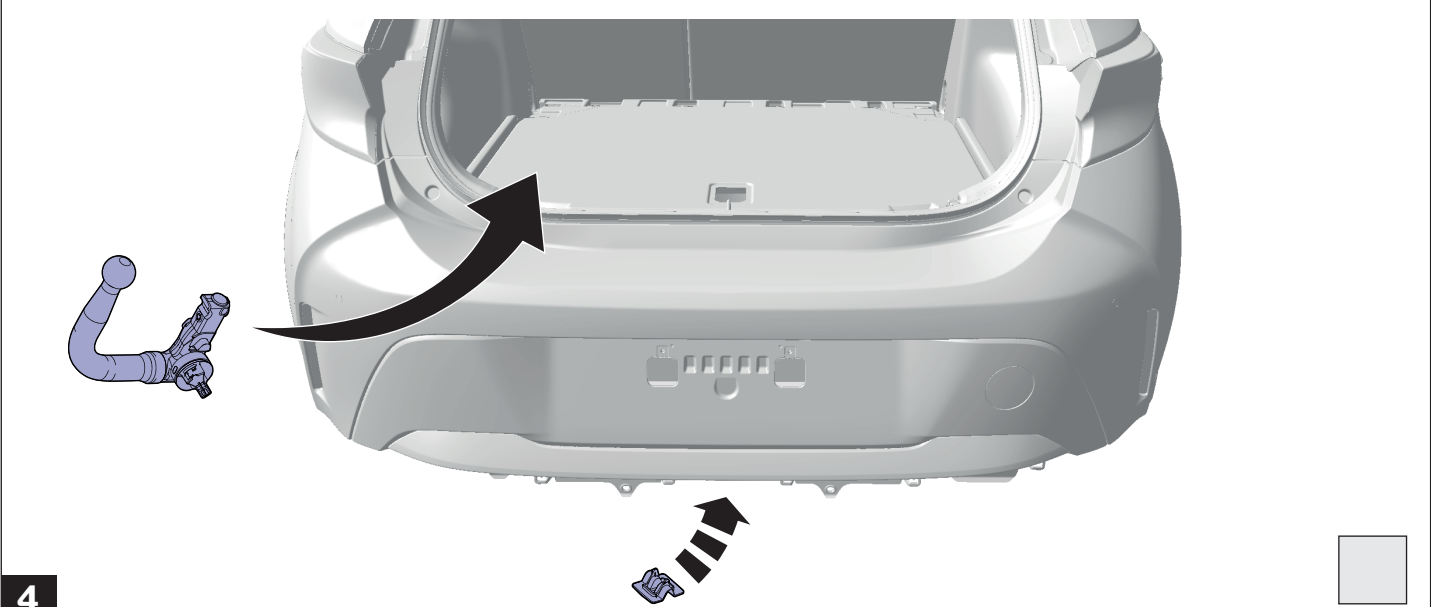

**5**

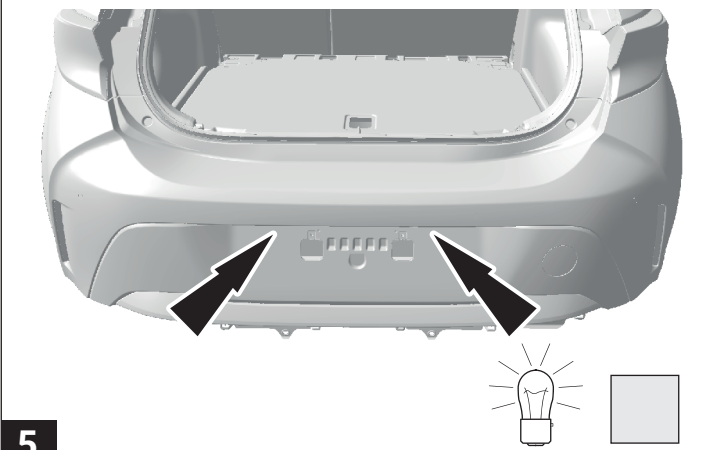

**6**

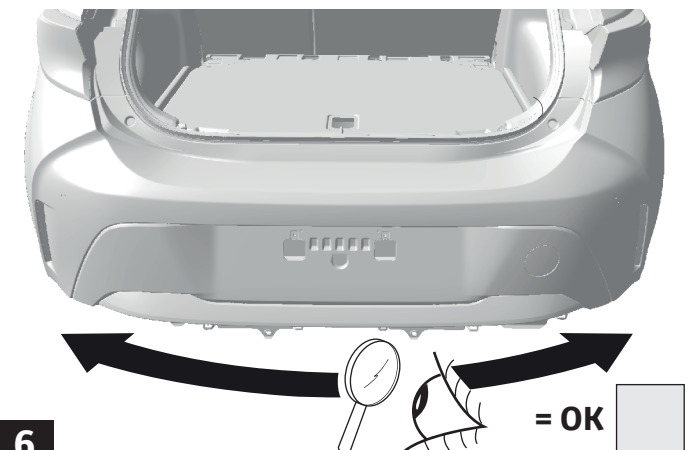

= OK

**Installation Date:**

... / ... / ...

**Technician Name & Signature:**

**Stamp:**