



**TOYOTA**

ALWAYS A  
BETTER WAY

# Hilux-EC/DC

## Door handle garnish

Installation instructions

Model year: As from 2015/04

Vehicle code: GUN1\*\*\*-D\*\*\*\*W  
GUN1\*\*\*-CN\*\*XW

Part number: PC168-0K009 Door handle garnish  
PZ415-00000-00 Adhesion Promoter (Qty 2)

Manual reference number: AIM 003 596-2

# Revision record

Rev. No.	Date	Page	Picture	Update	New	Deleted steps
1	23/07/2015	2-6	All	X		
Rev. No.	Date	Page	Step	Remarks		
△2	28.04.20	1		Vehicle code updated & Model year added		
△2	28.04.20	2		Tools added		
△2	28.04.20	3,4	2,3	Heating steps added		
△2	28.04.20	5,6,7	5,6,7,8,10	Warning signs removed		
△2	28.04.20	8		2 New washing warnings added		
△2	28.04.20	9		During and After Installation info added		

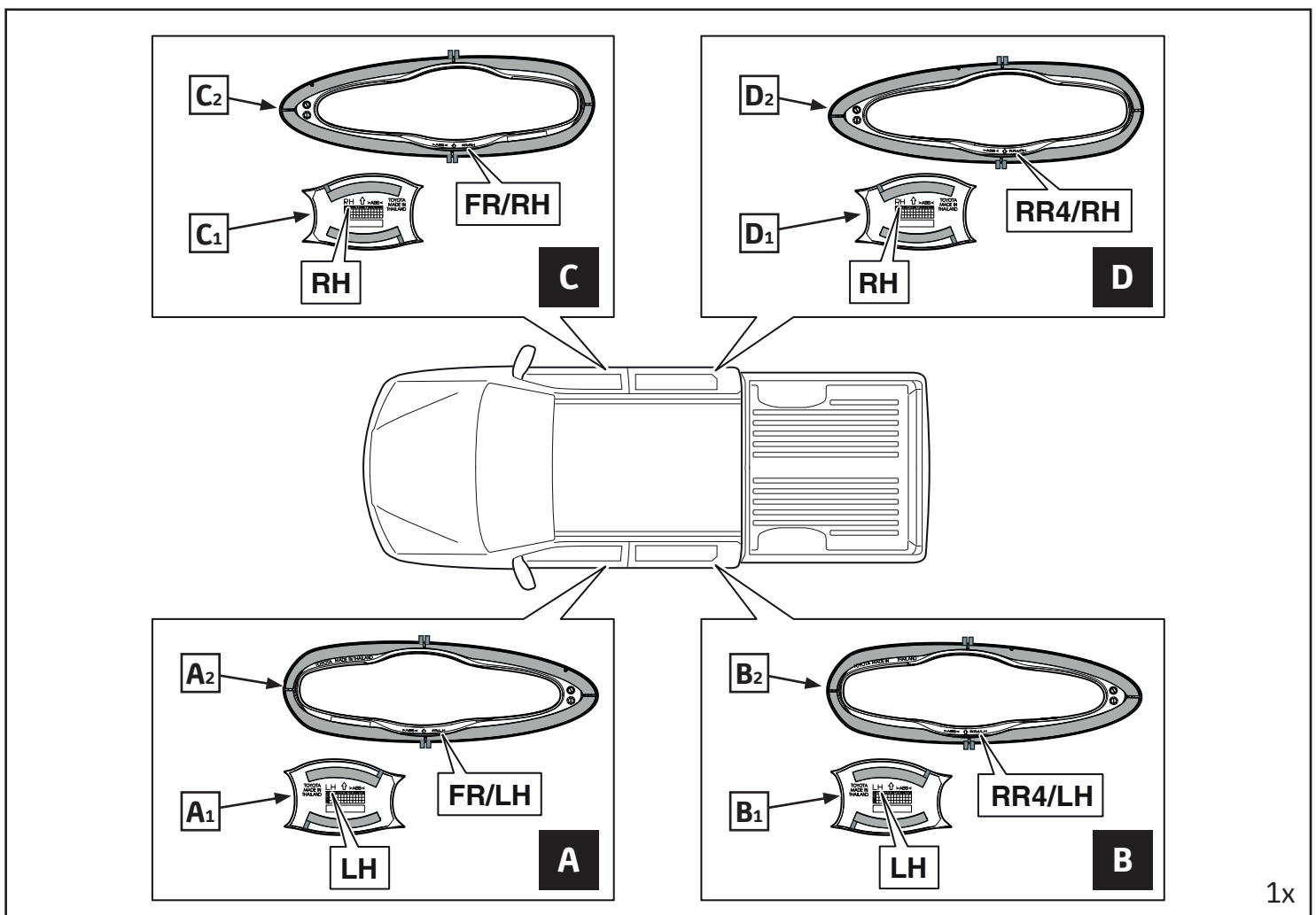

1x

	<p>AIM 003-516-*</p>	<p>PZ415-00000-00</p> <p>adhesion promoter 3M 4298 UV 2x</p>	<p>△2</p>	<p>△2</p>
--	----------------------	--	-----------	-----------

**INFO**



**Material Safety Data Sheet**

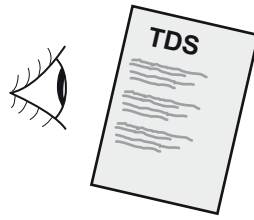

**Technical Data Sheet**

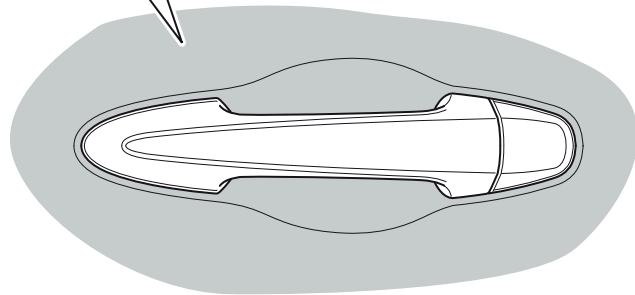
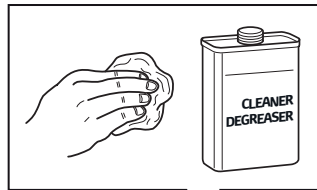
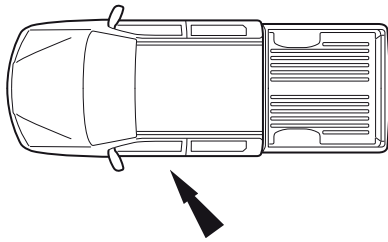
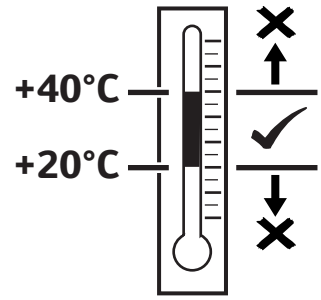

2

1

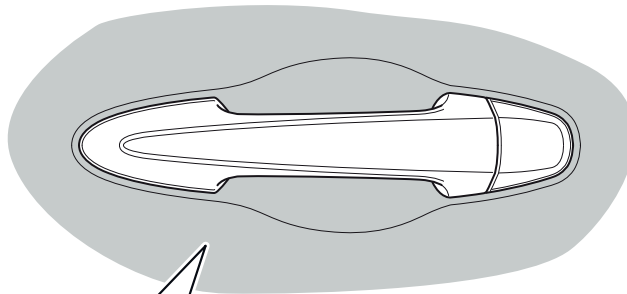



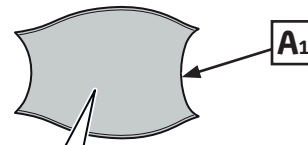
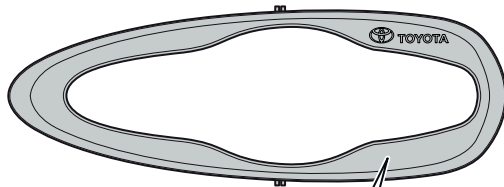
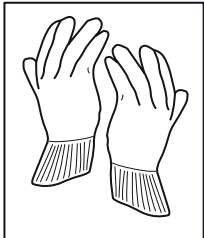

2

<p>1</p>	<p>&lt; 20°C → 2</p> <p>20°C - 40°C → 3</p>	<p>2</p>
<p>3</p>	<p>20°C - 40°C → 3</p>	<p><b>INFO</b></p>

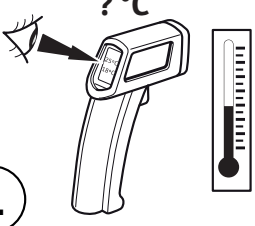
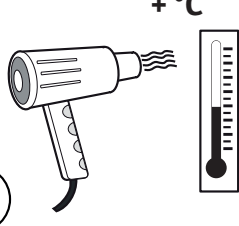
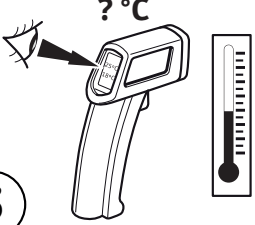

2

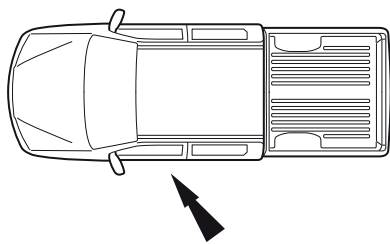

<p>1</p> 	<p>&lt; 20°C → 2</p> <p>20°C - 40°C → 4</p>	<p>2</p> 
<p>3</p> 	<p>20°C - 40°C → 4</p>	<p><b>INFO</b></p>  <p>3 → 9</p>  

3

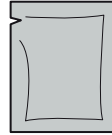

<p>1</p>  <p>adhesion promoter 3M 4298 UV</p>	<p>2</p>  <p>&gt; 1.5 min. &lt; 1 h.</p>
---	---

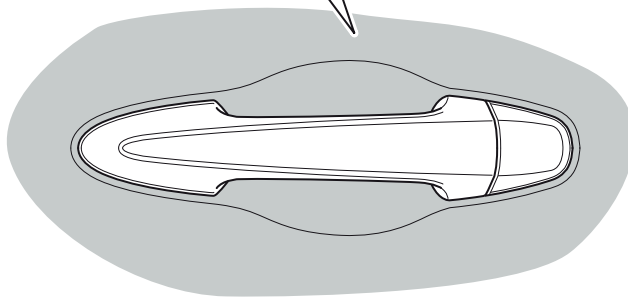

4

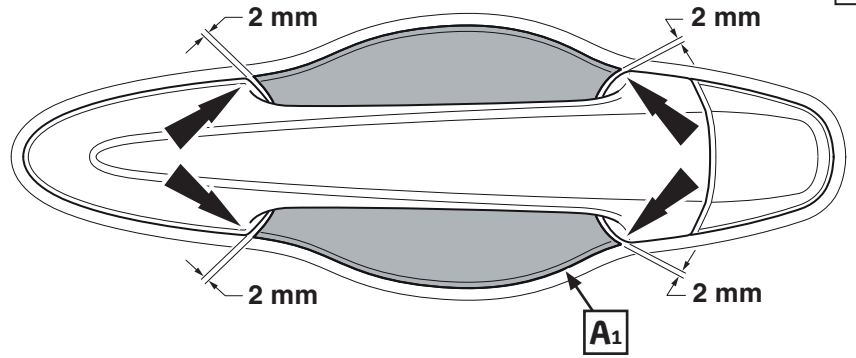
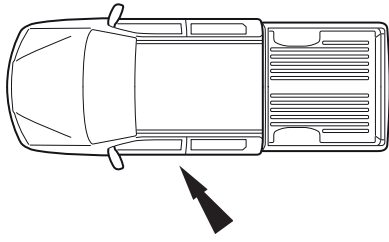

5

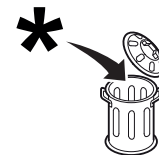
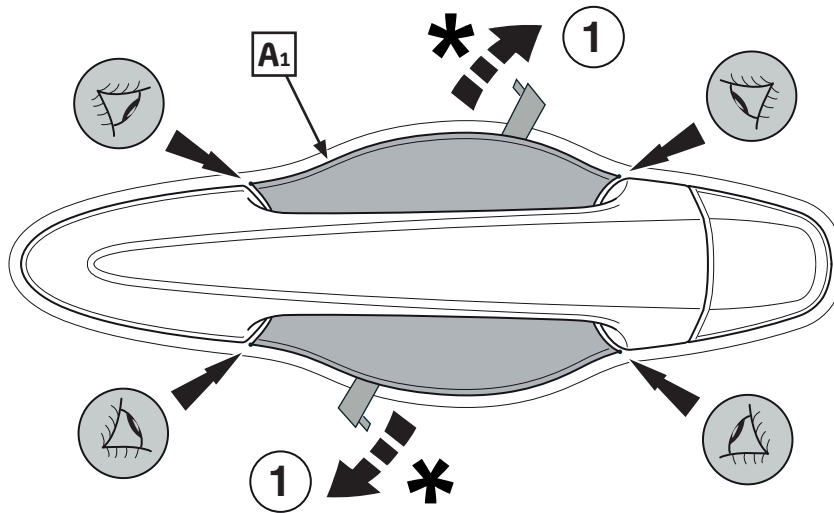
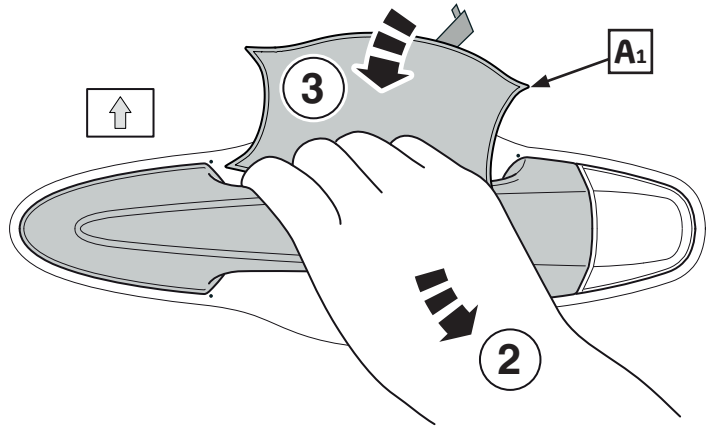
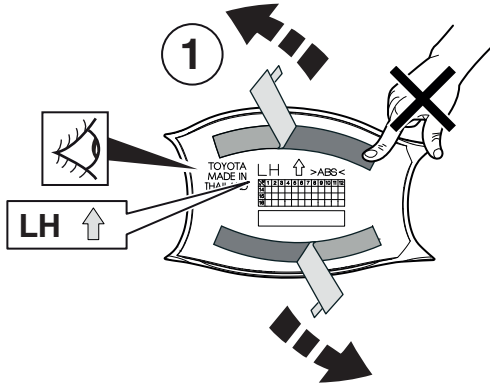

6

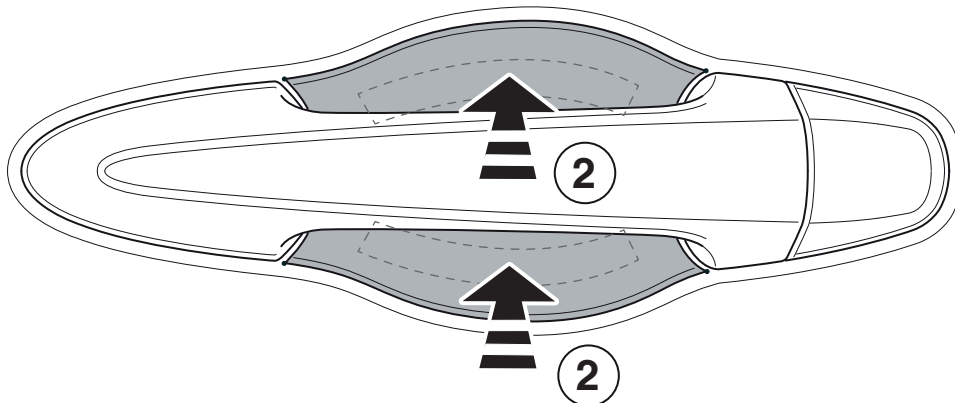

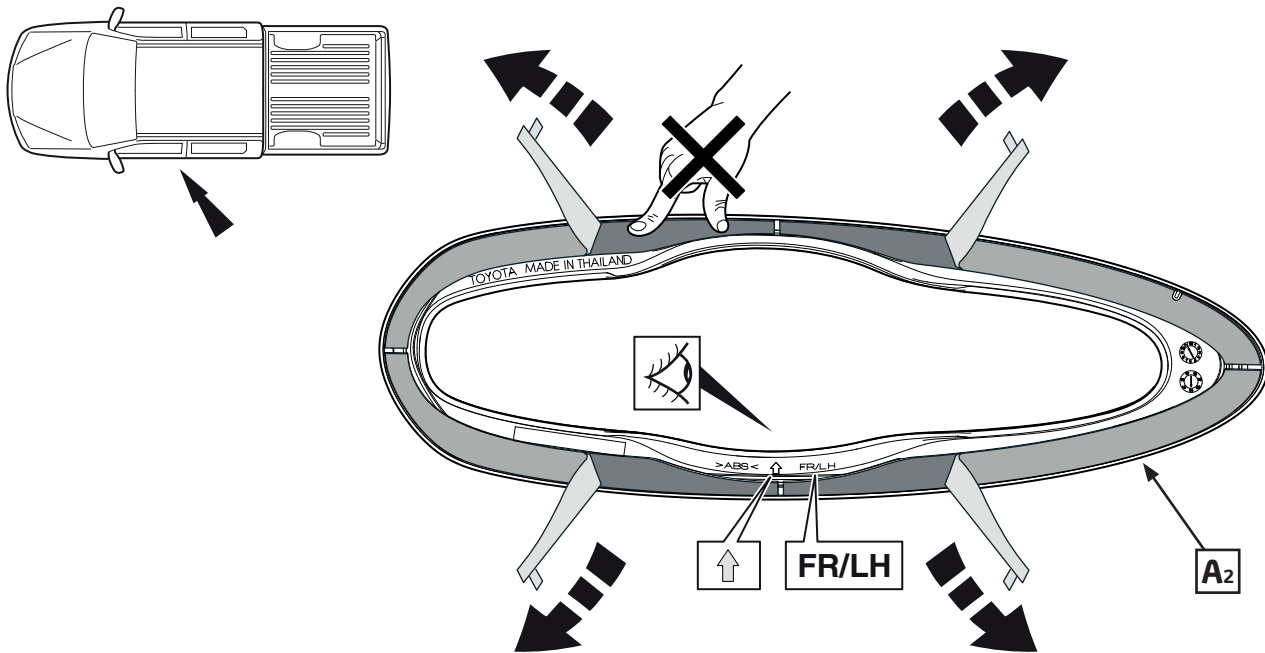

7

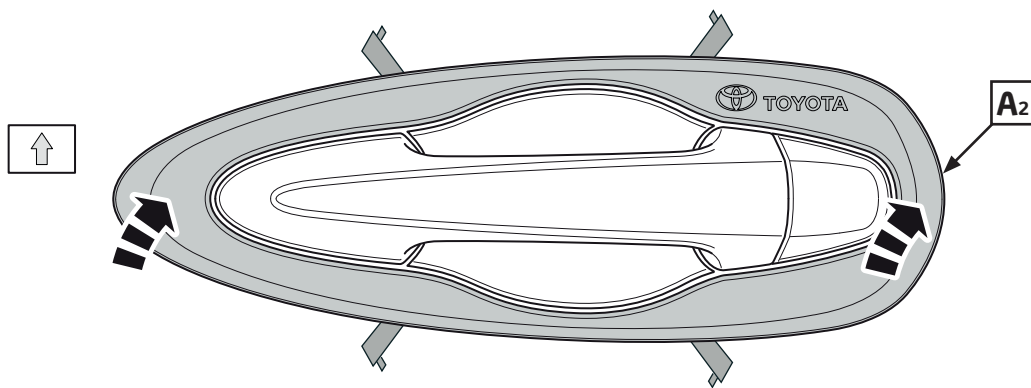
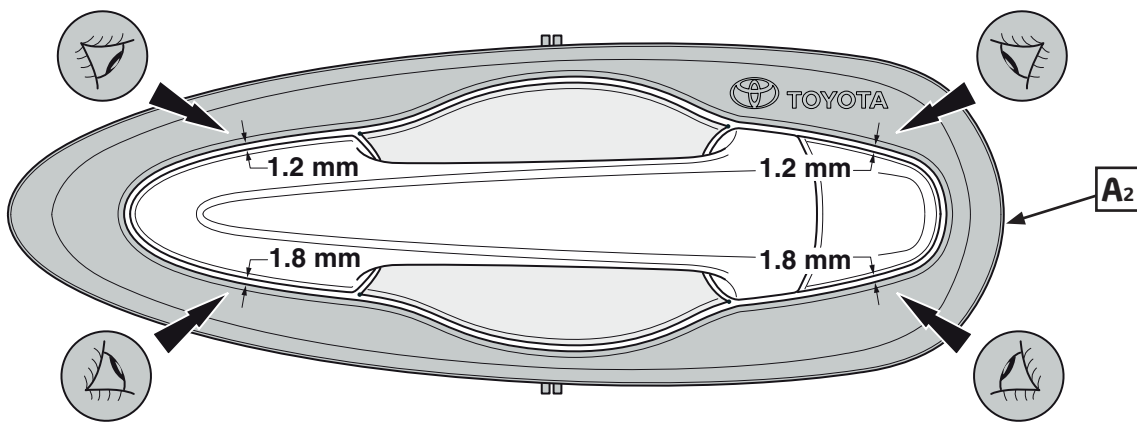

8

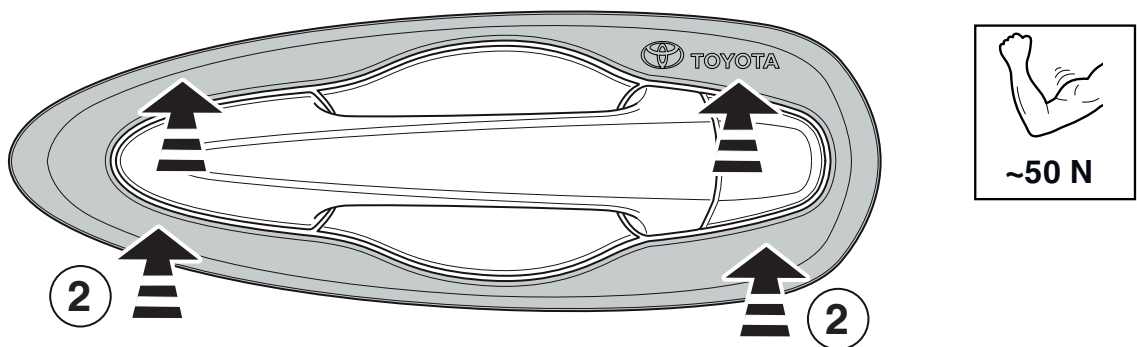
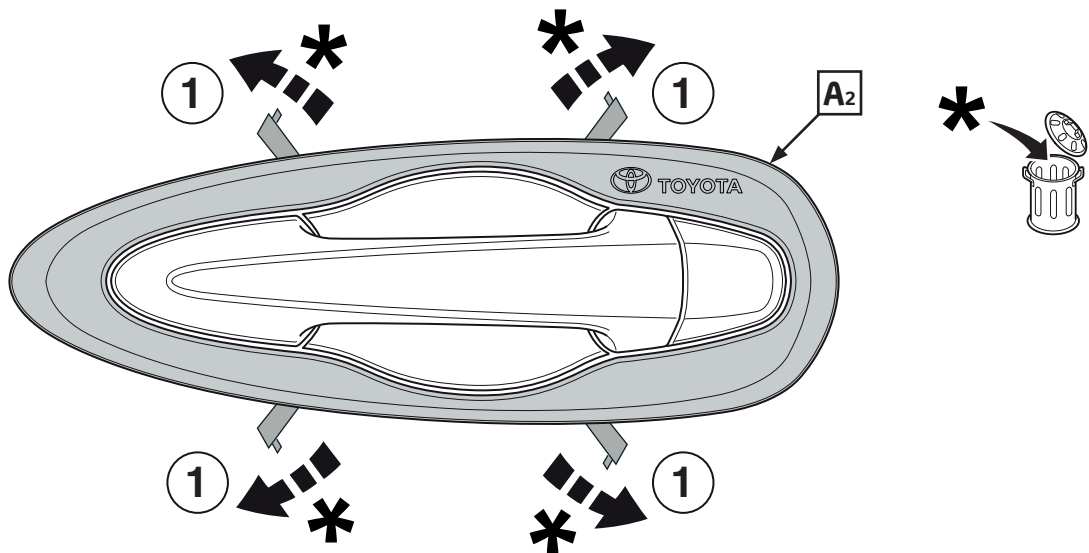

9

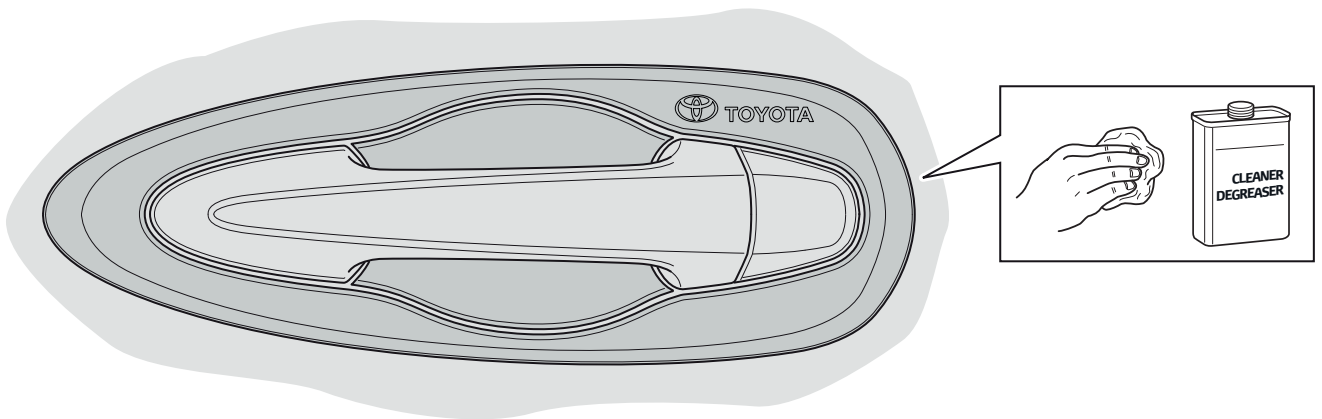

10

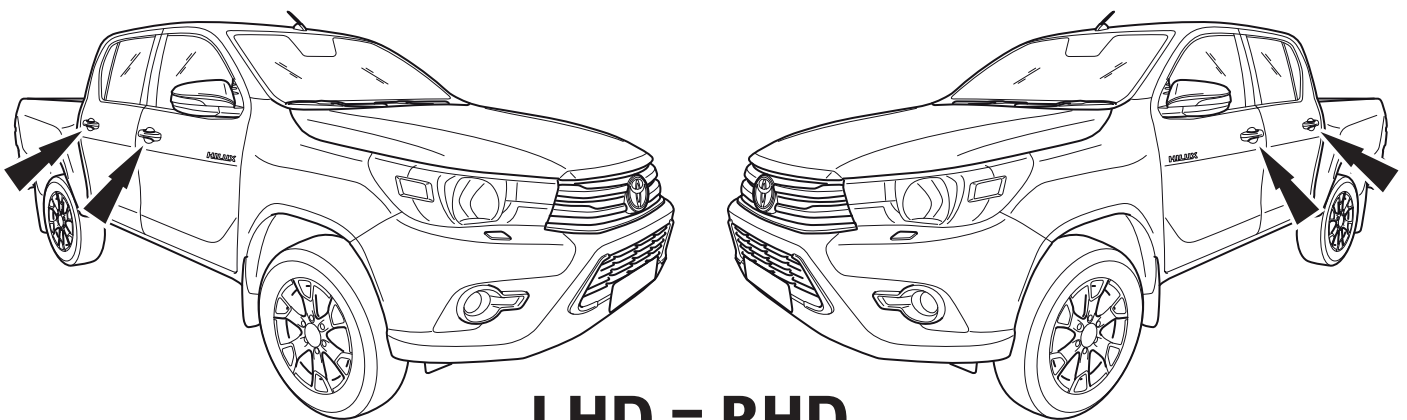

**LHD = RHD**

**A = B C D**  **1 - 10**

11

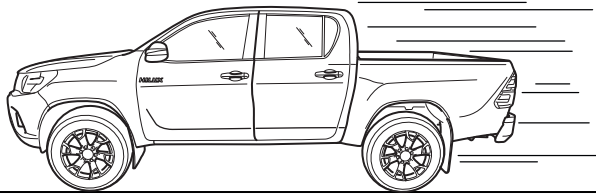
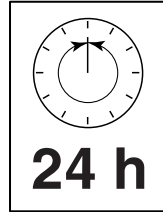
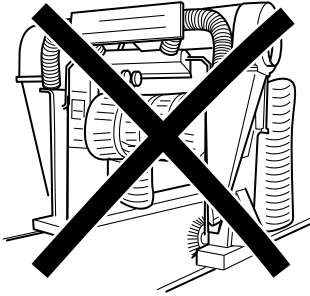
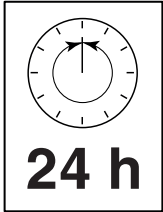

Max. 90 Km/h

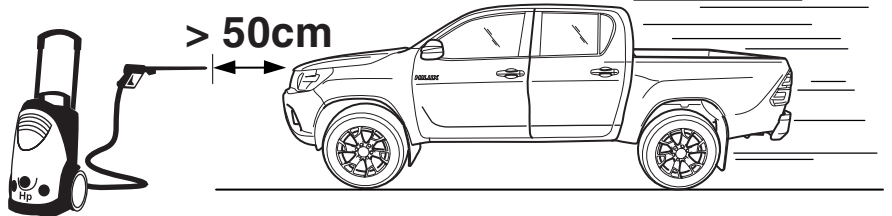
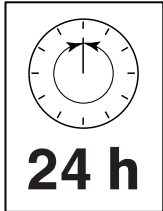



# CHECK SHEET Page 1 of 1



**TOYOTA**

Model / Year

Hilux-Extra/Double cab  
As from 2015/04

Door handle  
garnish

ALWAYS A  
BETTER WAY

VIN n°

## DURING INSTALLATION

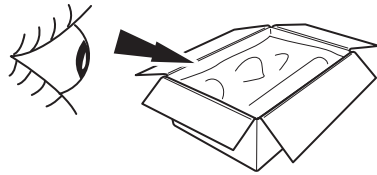

P/N = OK

1

## AFTER INSTALLATION

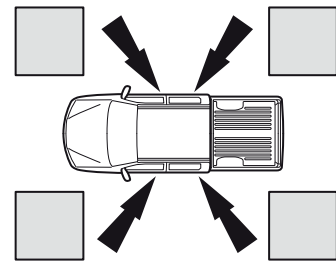
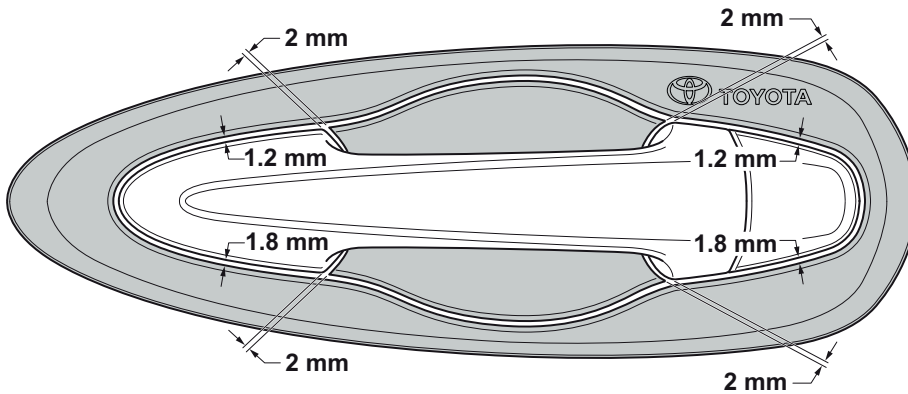

1

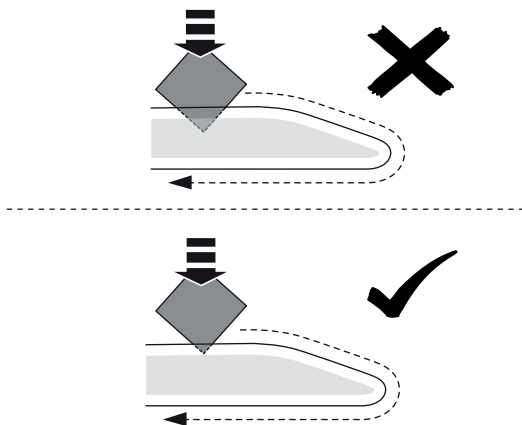

2

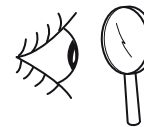
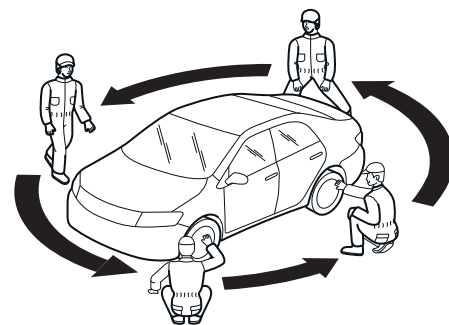

= OK

3

Installation Date:

. . / . . / . . . .

Technician Name & Signature:

Stamp: