

N1 Conversion kit TNO

Installation instructions





Model year:	2017/08
Vehicle code:	**J150L-GK*E*W
Part number:	PW710-60000
Weight:	74kg

Manual reference number: AIM 004 164-0

Revision Record

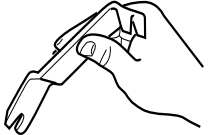
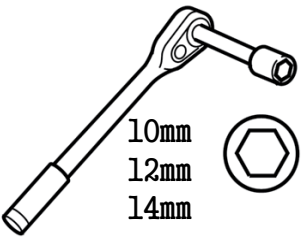
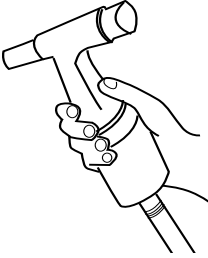
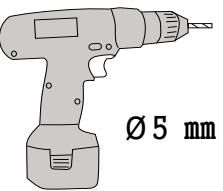
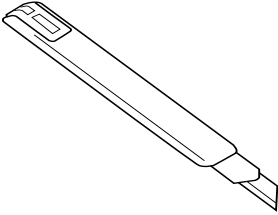
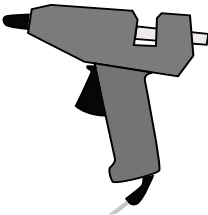
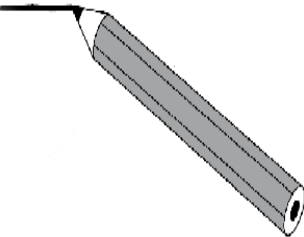
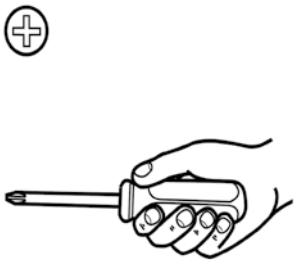
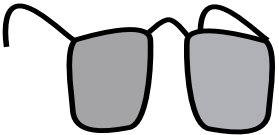
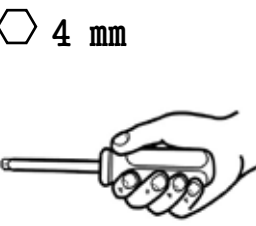

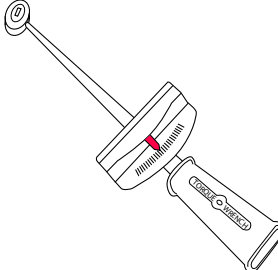

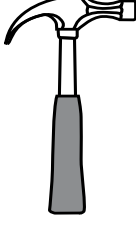
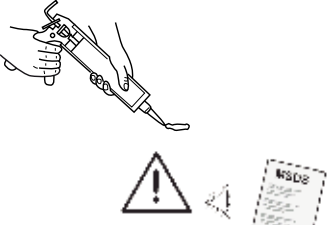

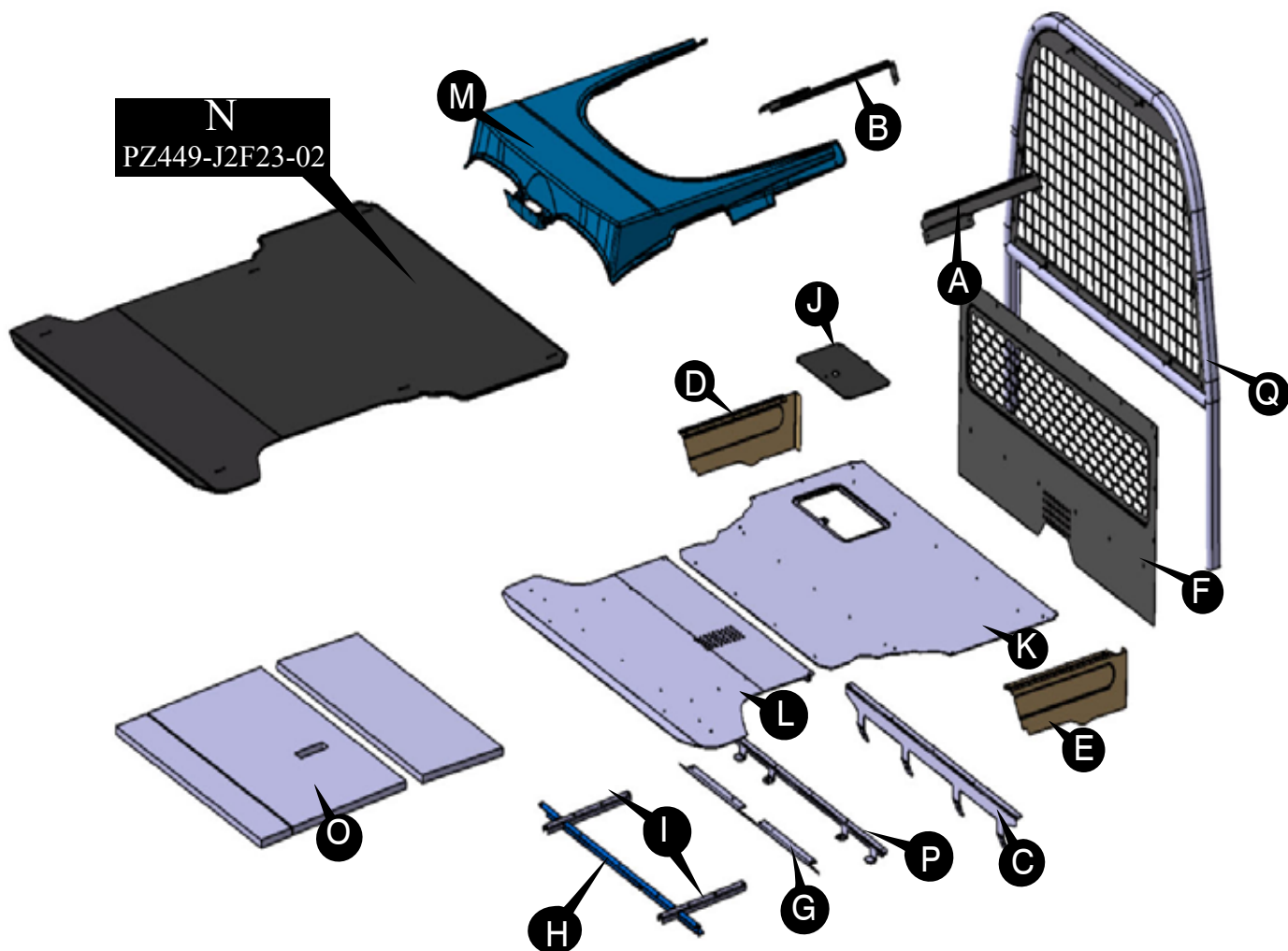
Rev nr	Date	Page	Picture	Update	New	Deleted steps



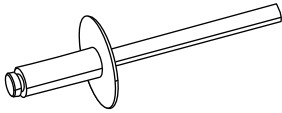
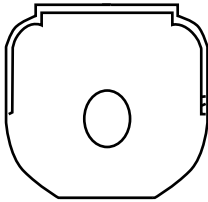
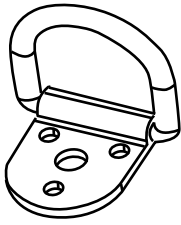
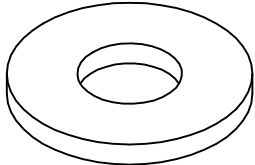
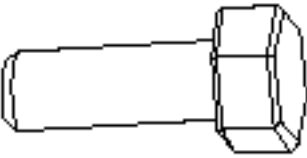
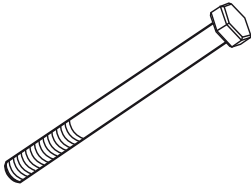
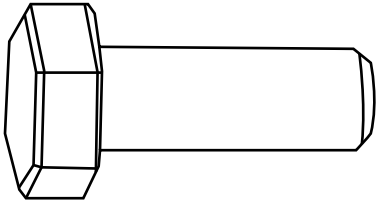
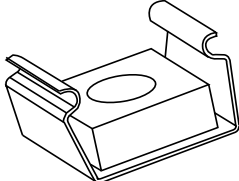
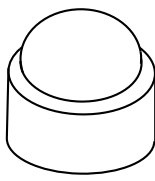
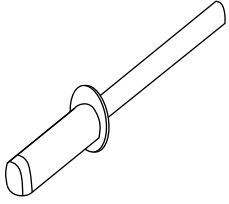
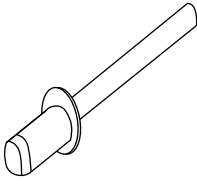
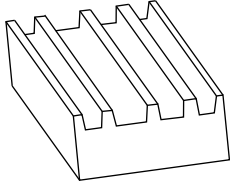
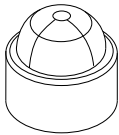
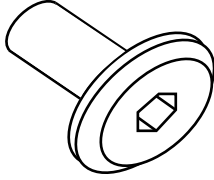
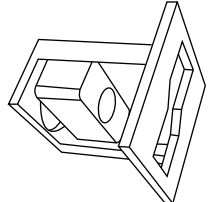

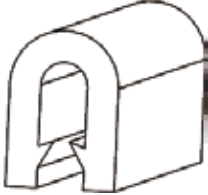
Tools

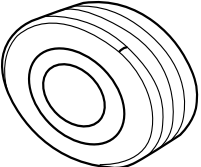
	 <p>10mm 12mm 14mm</p>		 <p>Ø 5 mm</p>
			
	 <p>4 mm</p>		
			 <p>http://your.msds.be login: TMME password: MSDS</p>

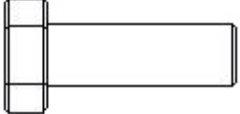

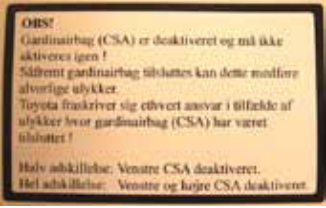
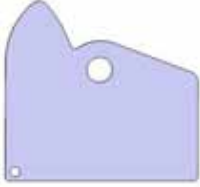
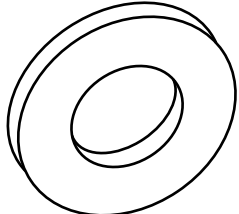
Number	Quantity	Definition
A	1	Handle Bracket Right
B	1	Handle Bracket Left
C	1	Front floor support
D	1	Side Cover Left
E	1	Side Cover Right
F	1	Lower Seperator
G	1	Floor support 3
H	1	Rear floor support
I	2	Stiffer for rear Floor
J	1	Service Hatch
K	1	Front floor, 5-seats
L	1	Rear floor, 5-seats
M	1	Roof lining, 5-seats
N	1	PZ449-J2F23-02 Full carpet floor 5 seats
O	1	Insulation mat assy
P	1	Floor support 2 5-seats
Q	1	Tube separator Assy

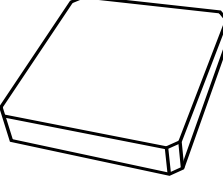
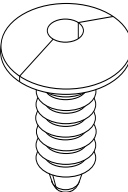
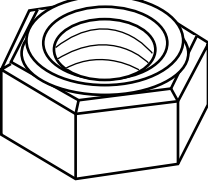
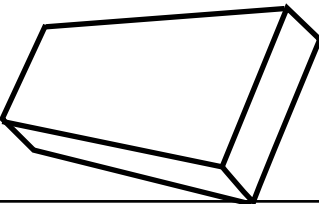
<p>A1 5x10x16 NSS 34 PCS</p> 	<p>A2 6 PCS</p> 	<p>A3 6 PCS</p> 
<p>A4 6,4x15x1,5 20 PCS</p> 	<p>A5 6x16 6K 6 PCS</p> 	<p>A6 6x75 6K 2 PCS</p> 
<p>A7 6x20 6K 4 PCS</p> 	<p>A8 1 PCS</p> 	<p>A9 221 M06SW10 G 8 PCS</p> 
<p>A10 27 PCS</p> 	<p>B1 5x14 NSS 33 PCS</p> 	<p>B2 1050 mm</p> 
<p>B3 2 PCS</p> 	<p>B4 1 PCS</p> 	<p>B5 4 PCS</p> 
<p>B6 2 PCS</p> 	<p>B7 20mm</p> 	<p>B8 2PCS</p> 
<p>B9 2 PCS</p> 	<p>C1 4 PCS</p> 	<p>C2 8x25 6K BL 2 PCS</p> 

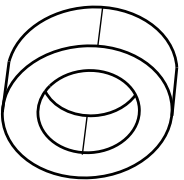
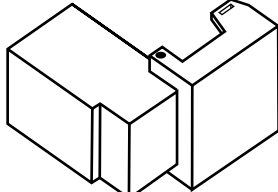
<p>C3 3 PCS</p>  <p>OBS! Gardnairbag (CSA) er deaktiveret og må ikke aktiveres igen! Sikkert gardnairbag tilsluttes kan dette medføre alvorlige ulykker. Toyota frakriver sig ethvert ansvar i tilfælde af ulykker hvor gardnairbag (CSA) har været tilsluttet! Hvis adskillige: Venstre CSA deaktiveret. Hvis adskillige: Venstre og højre CSA deaktiveret.</p>	<p>C4 2 PCS</p> 	<p>C5 8,4x17x2 2 PCS</p> 
<p>C6 1 PCS</p> 	<p>C7 30 PCS</p> 	<p>C8 2 PCS</p> 
<p>C9 6 NMU 8 PCS</p> 	<p>D1 4 PCS</p> 	<p>D2 1 PCS</p> 
<p>D3 11,3x18x8 3 PCS</p> 		
<p>XX Alternative dummy 2 PCS</p> 		

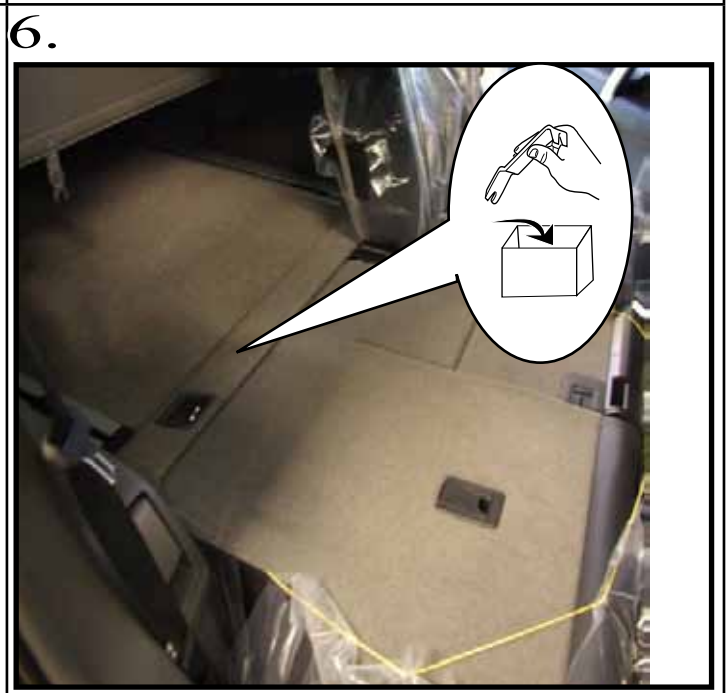
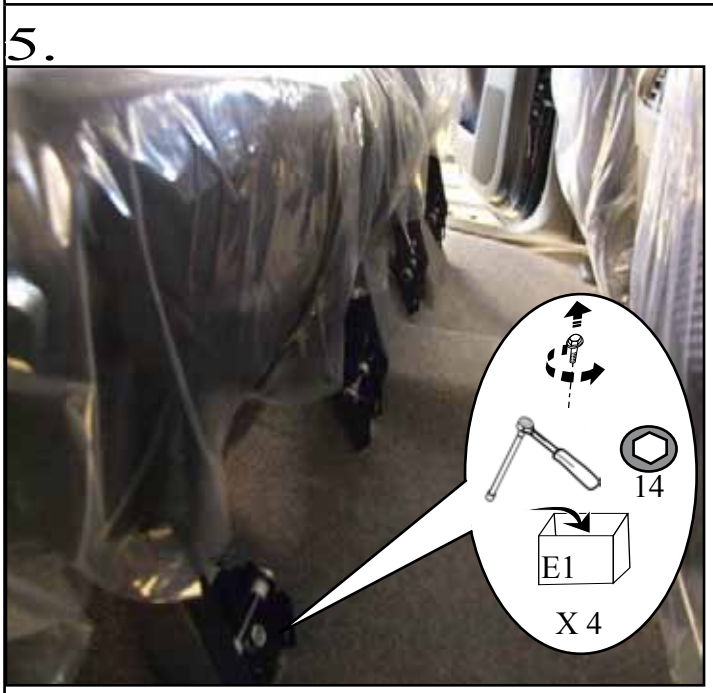
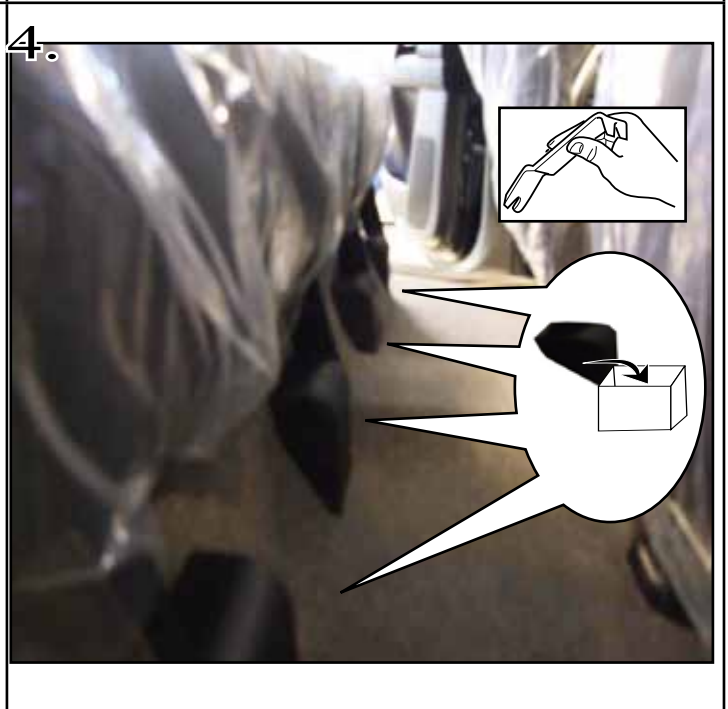
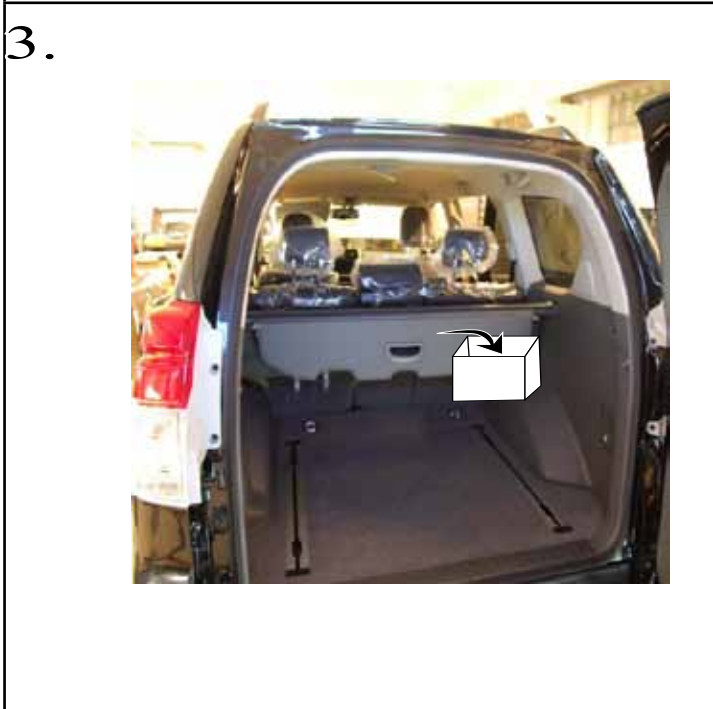
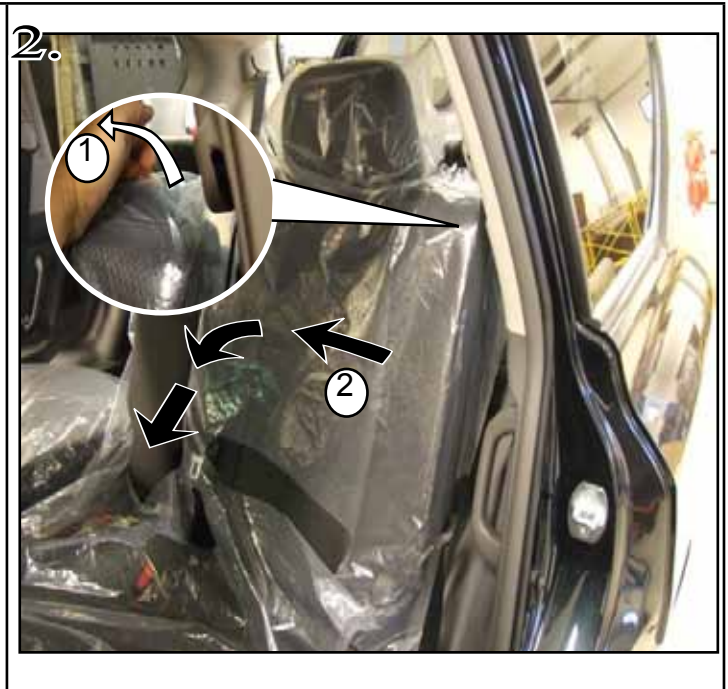
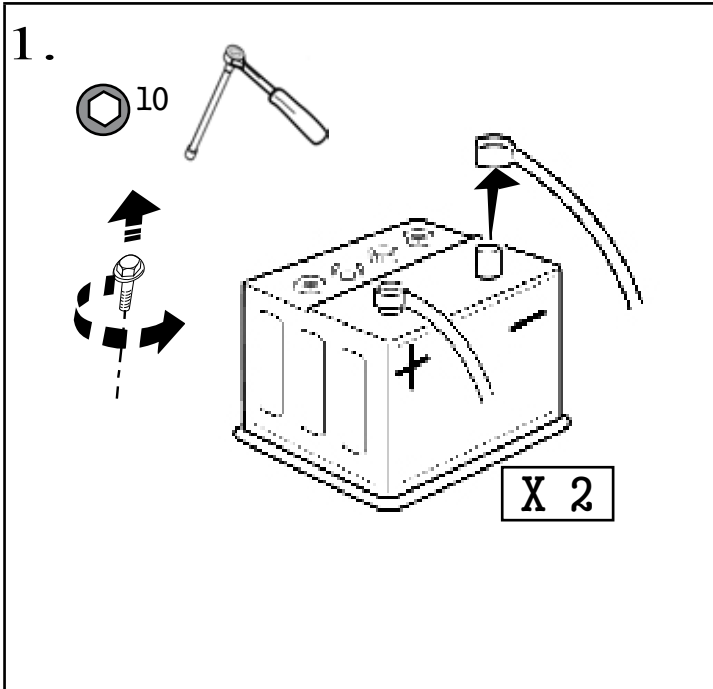

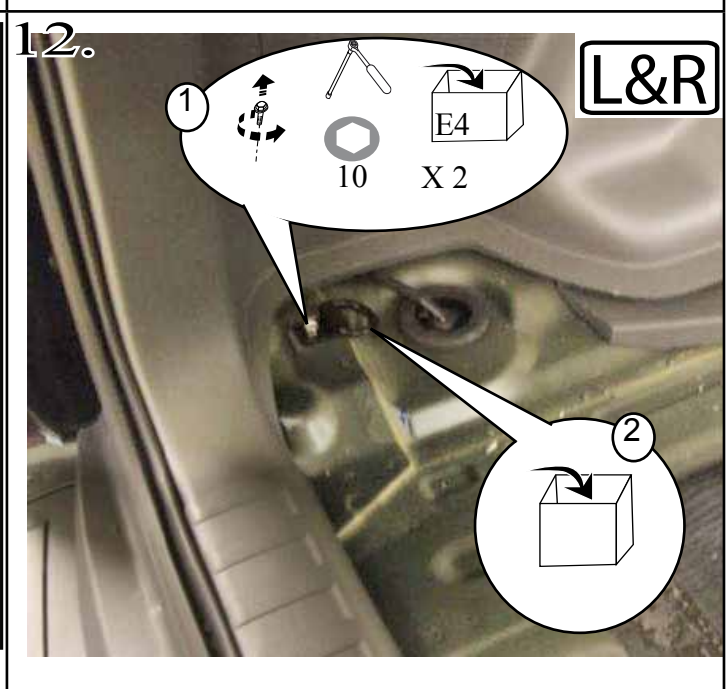
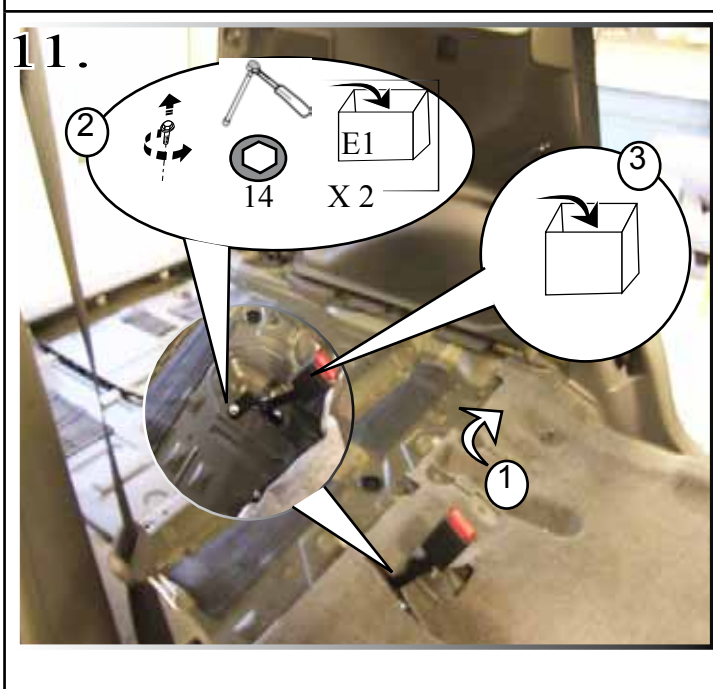
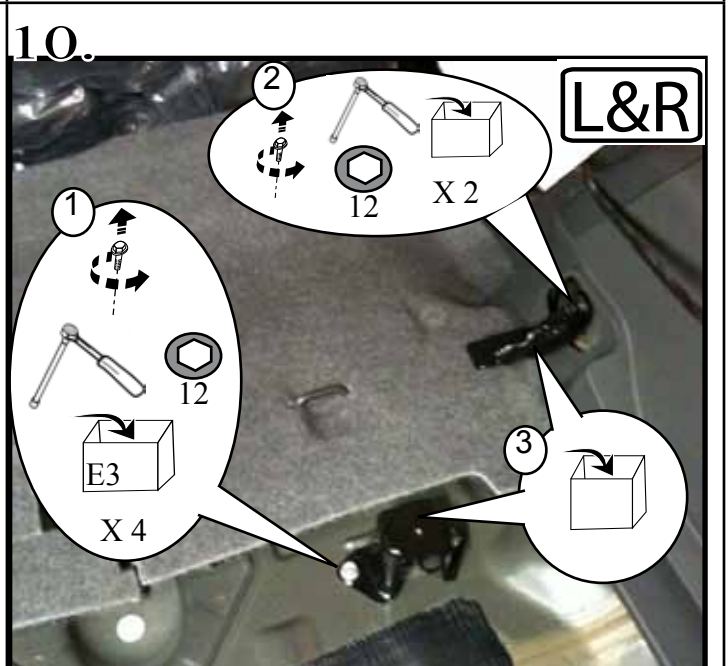
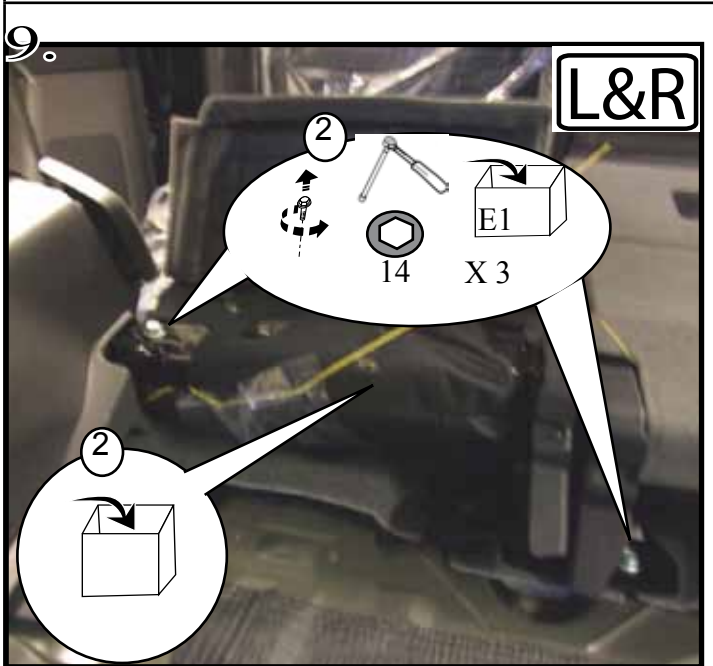
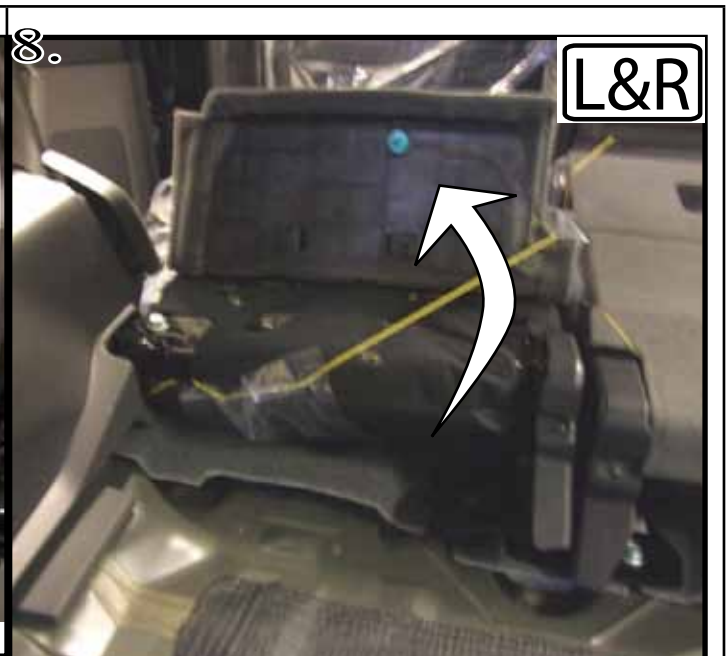
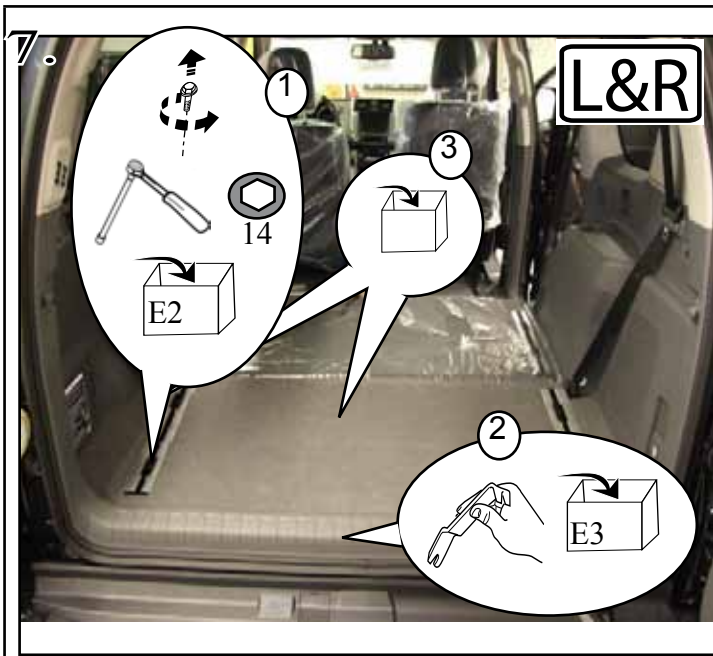

13.

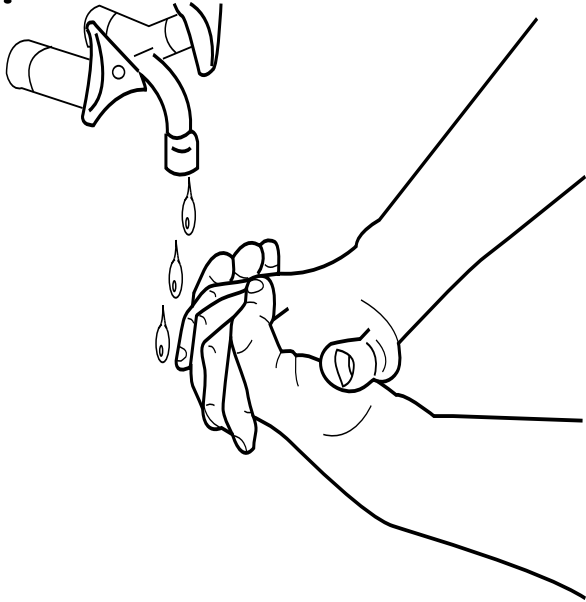

14.

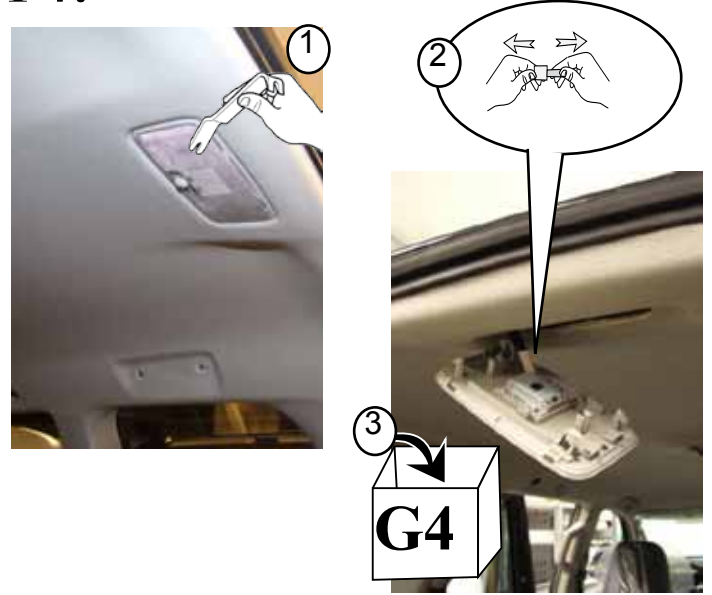

15.

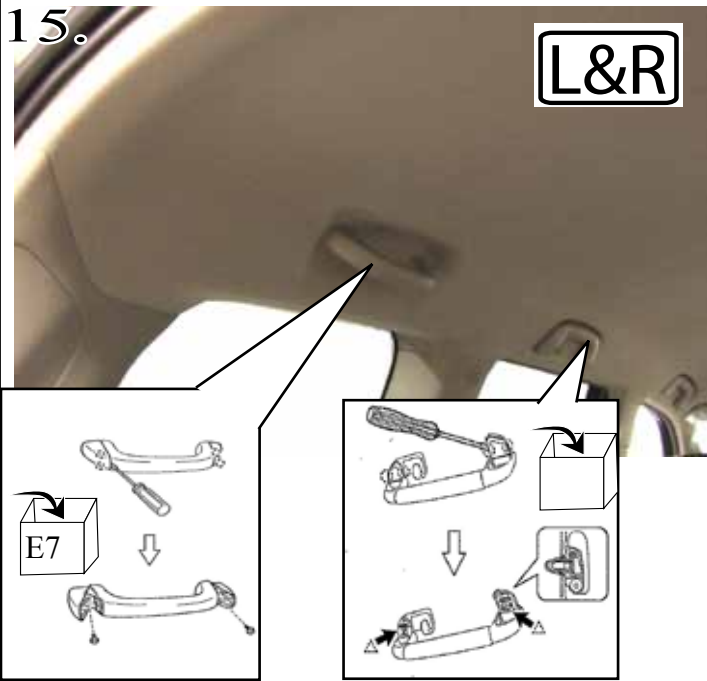

16.

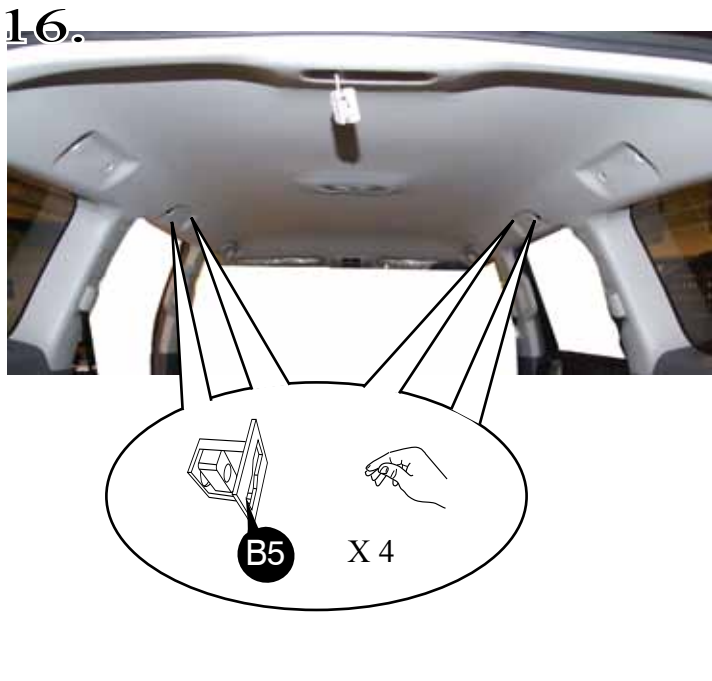

17.

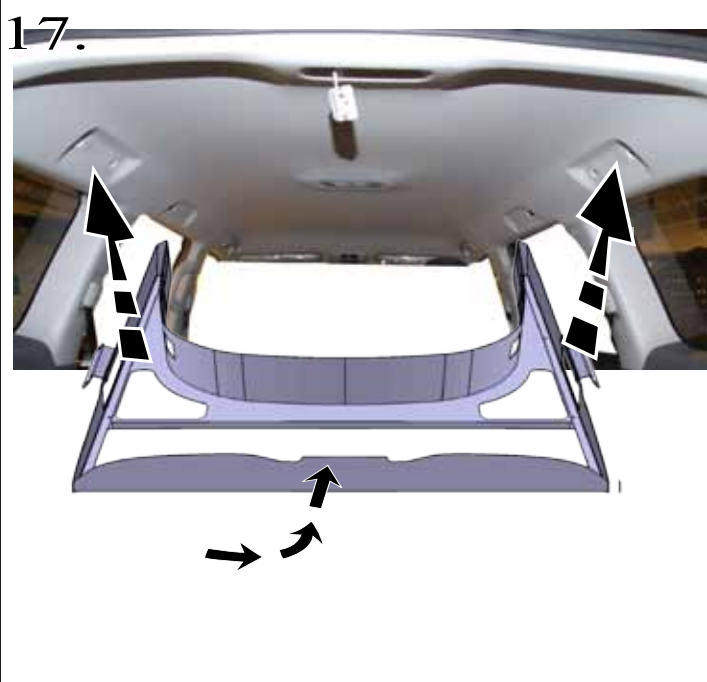

18.

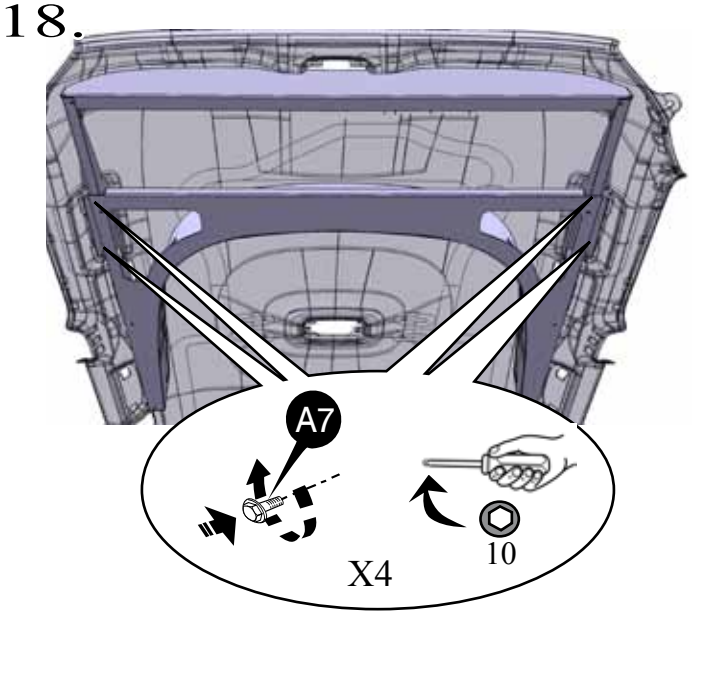

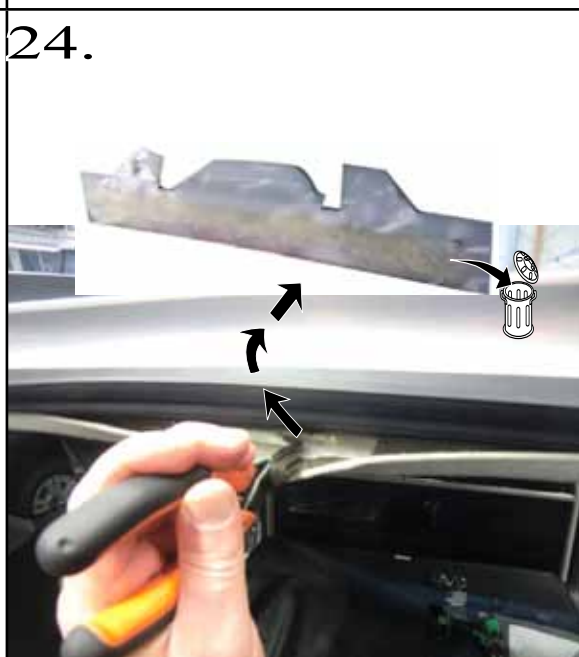
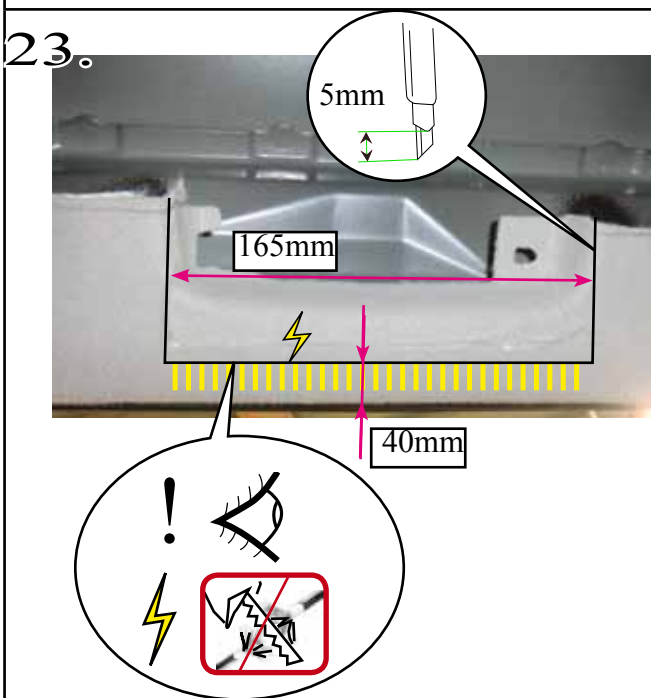
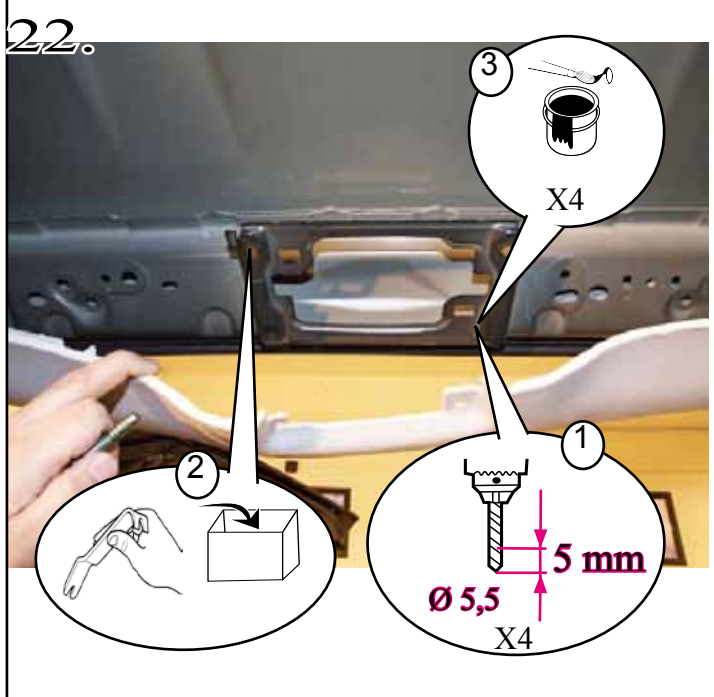
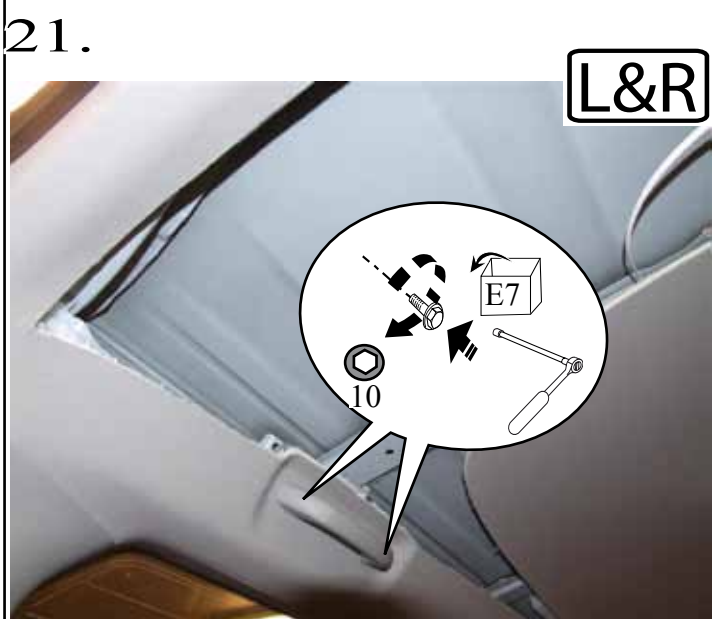
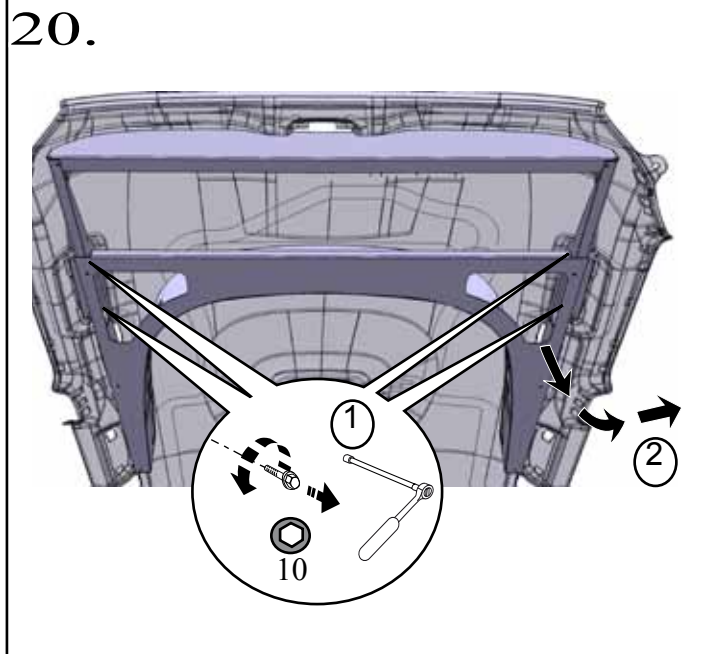
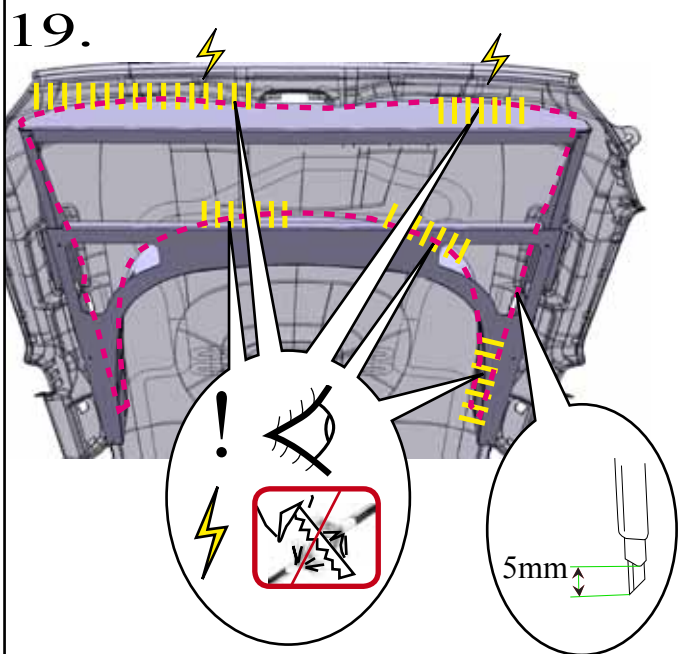

25.

L&R

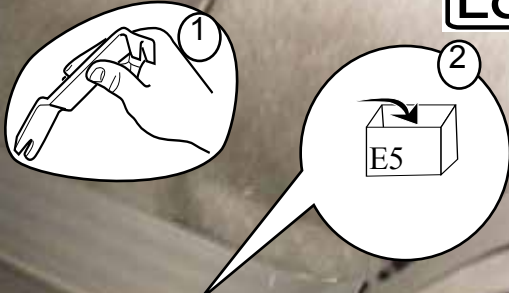

26.

L&R

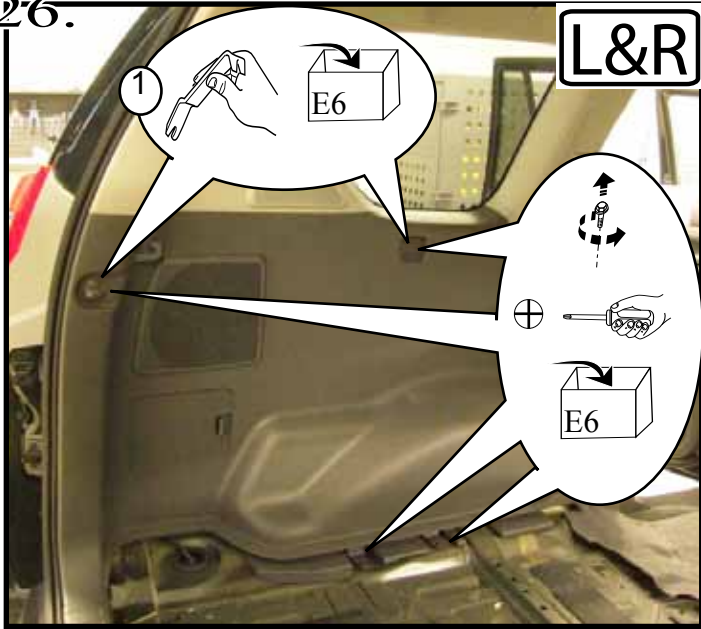

27.

L&R

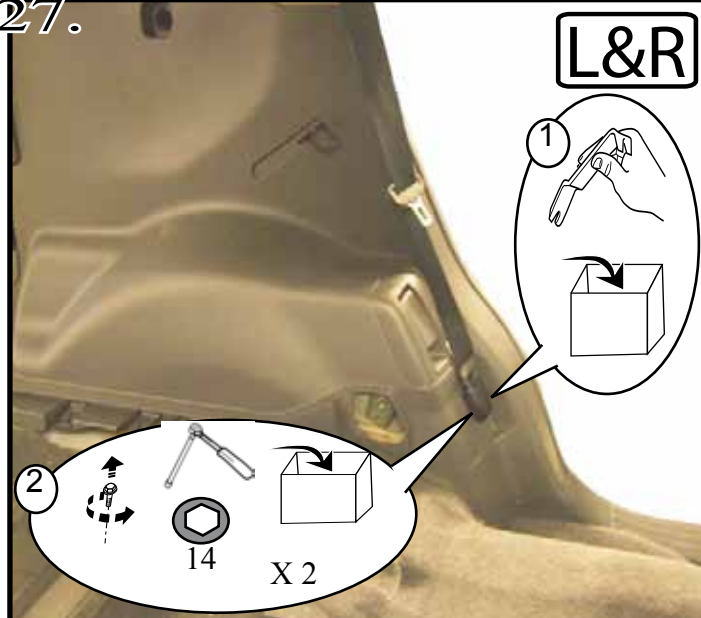

28.

L&R

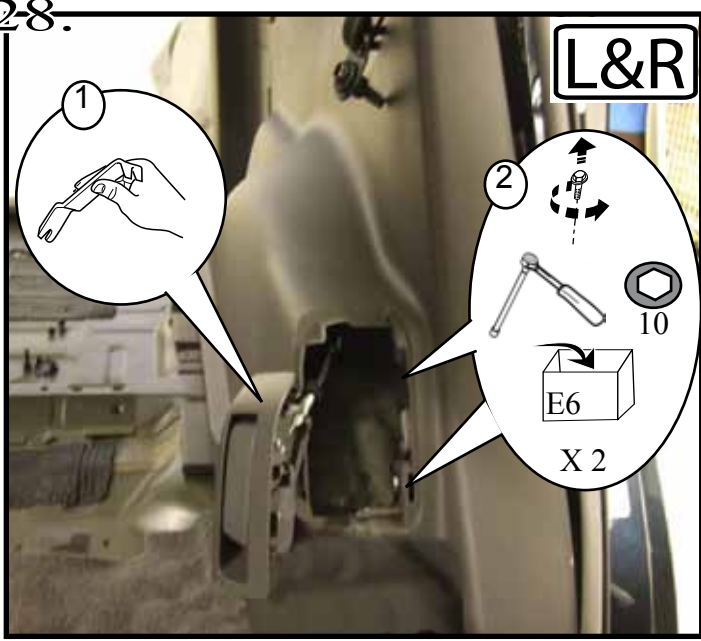

29.

L&R

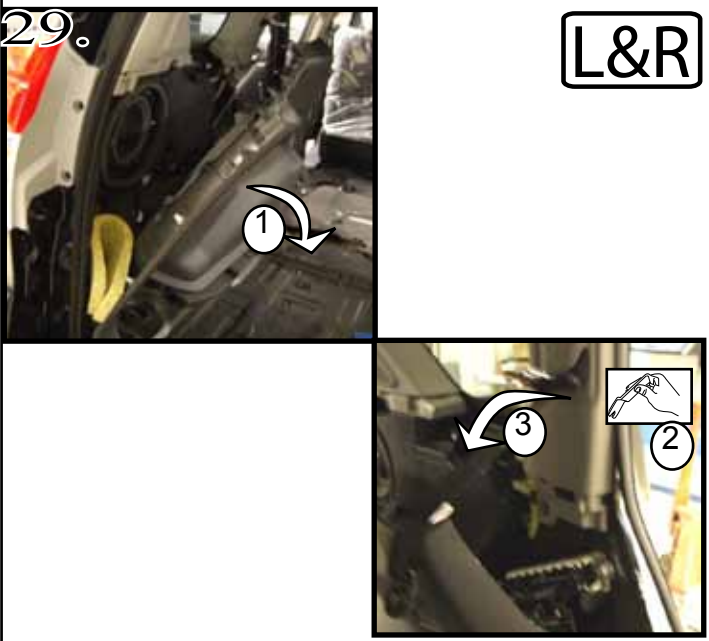

30.

L&R

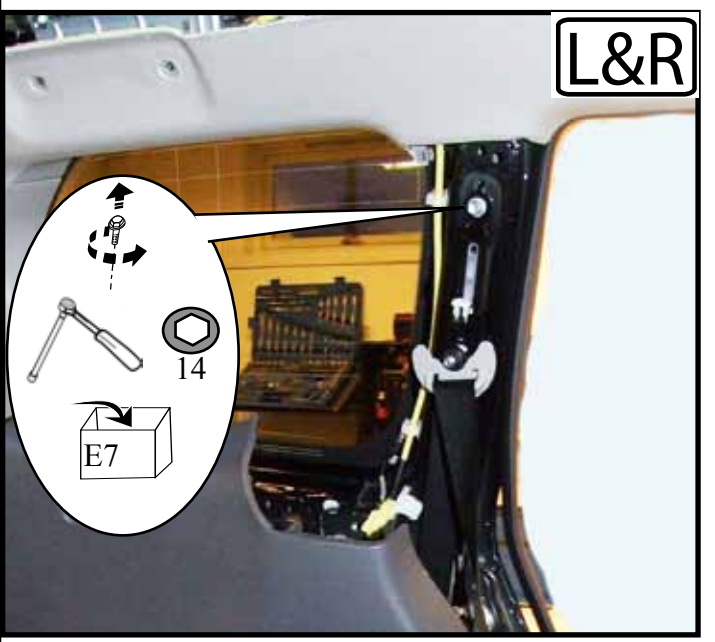

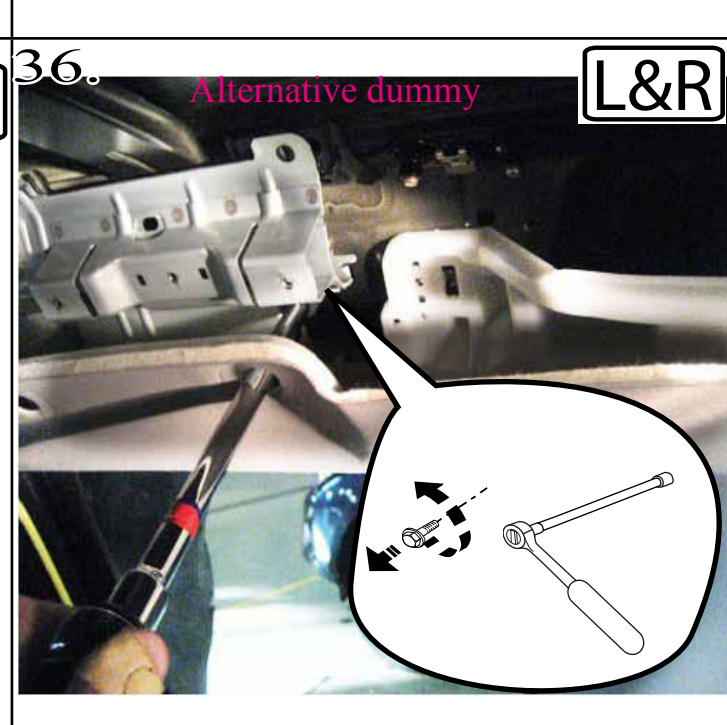
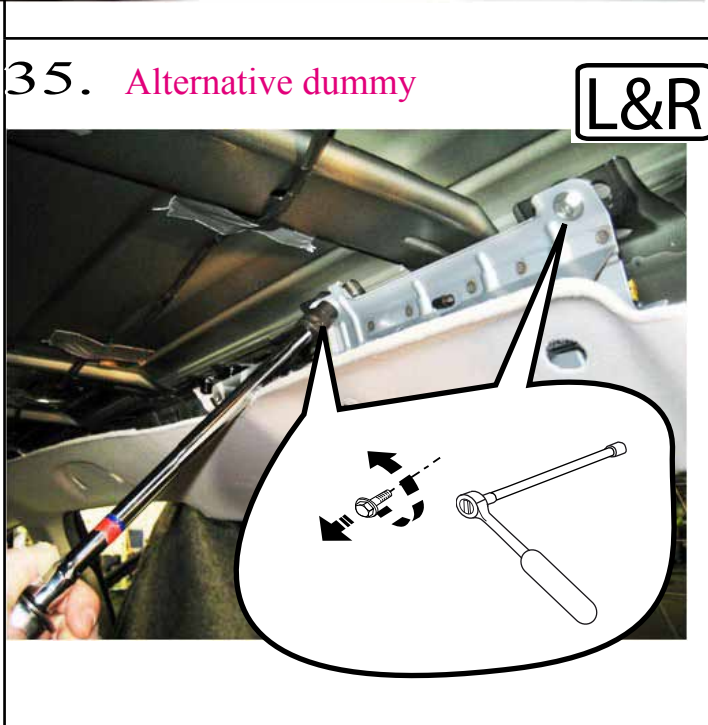
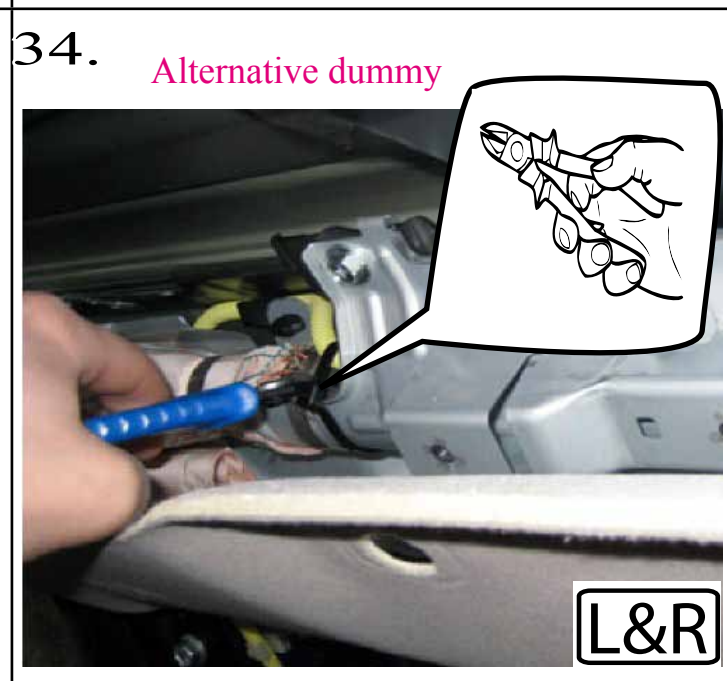
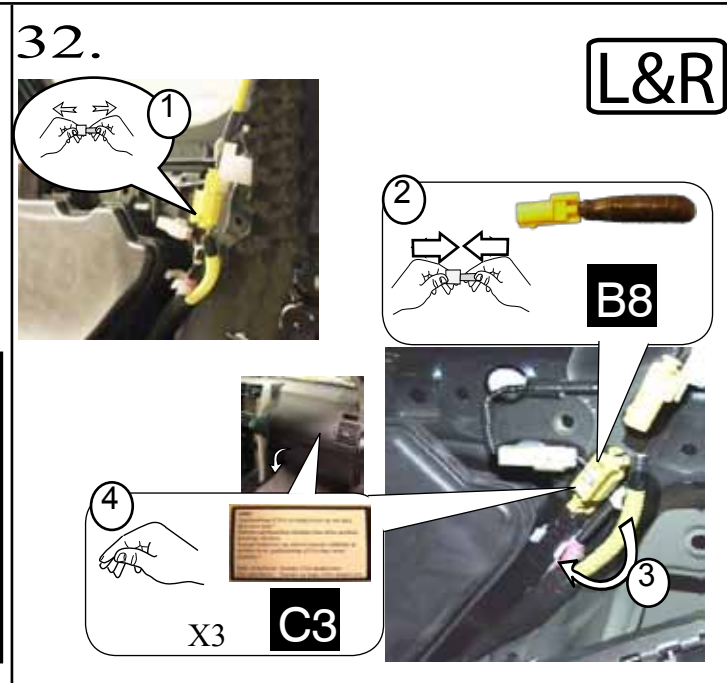
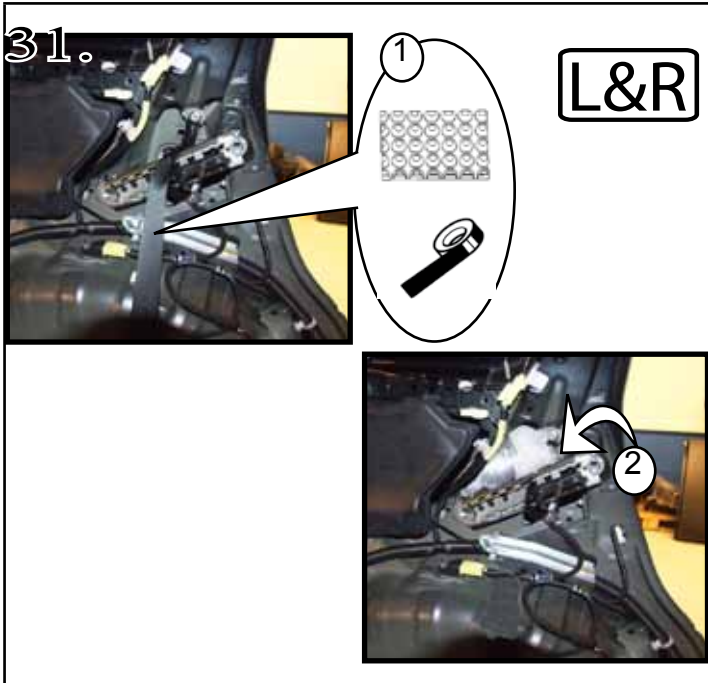

37. Alternative dummy

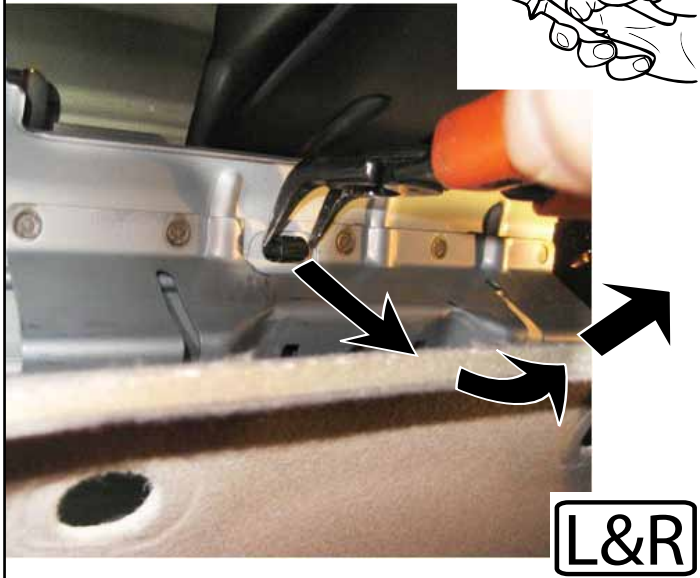

38. Alternative dummy

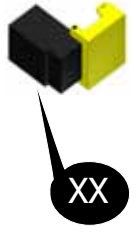

39. Alternative dummy



40. Alternative dummy

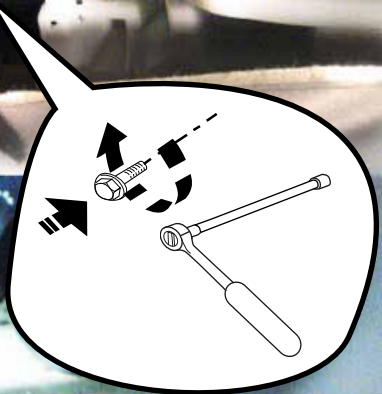
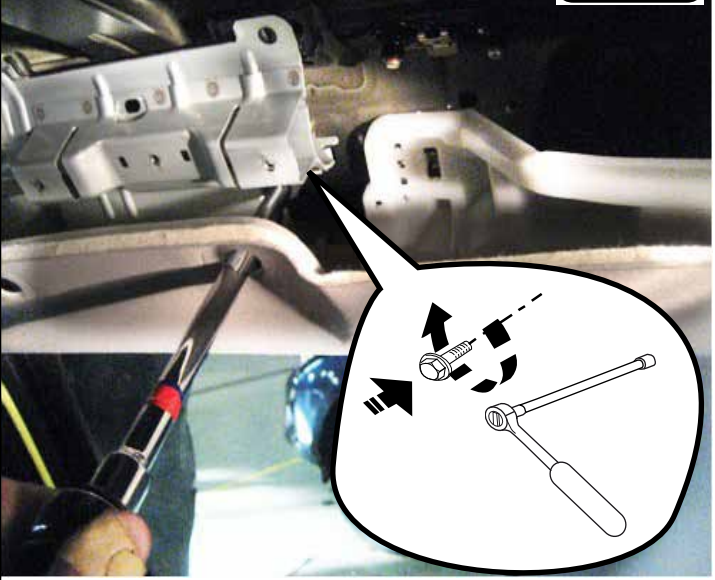

41. Alternative dummy

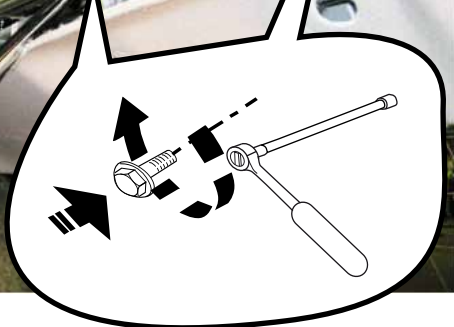
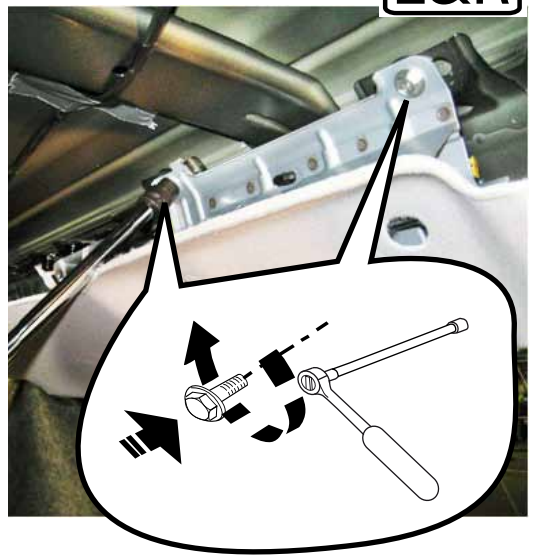

42. Alternative dummy



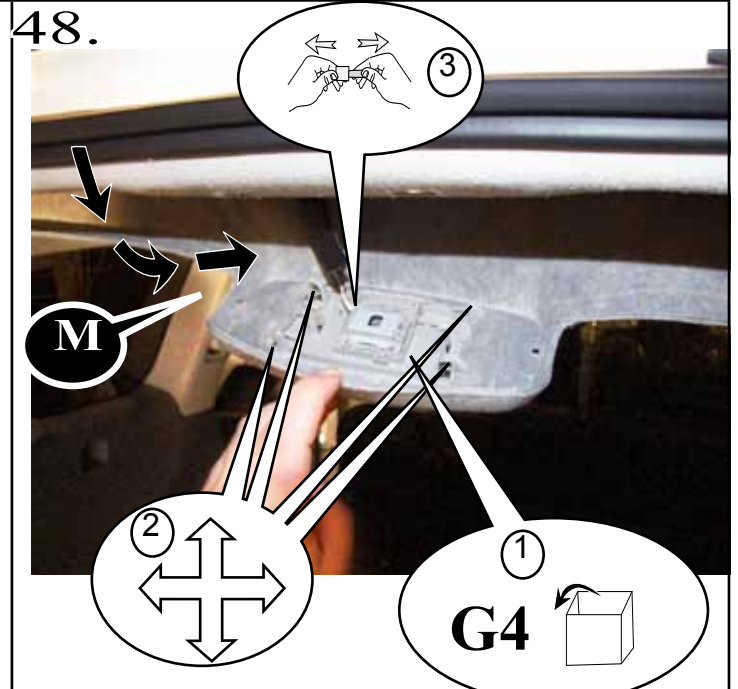
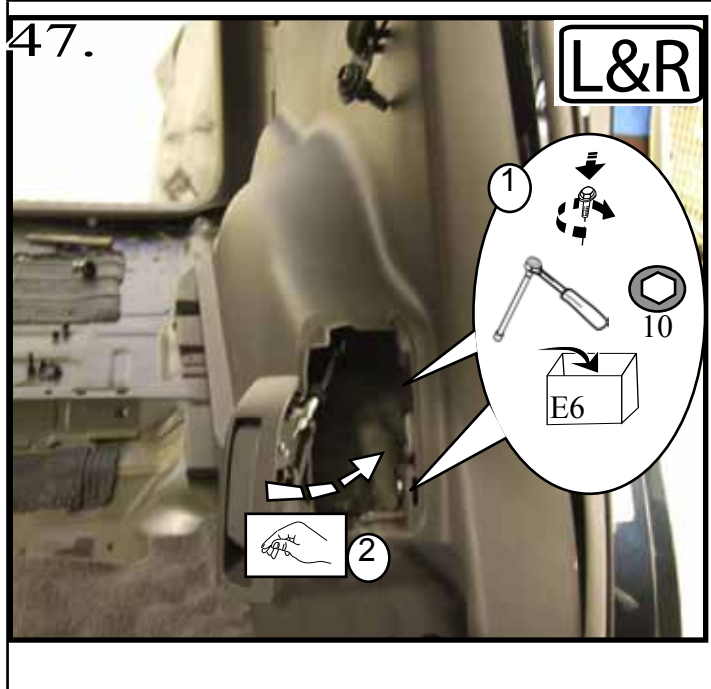
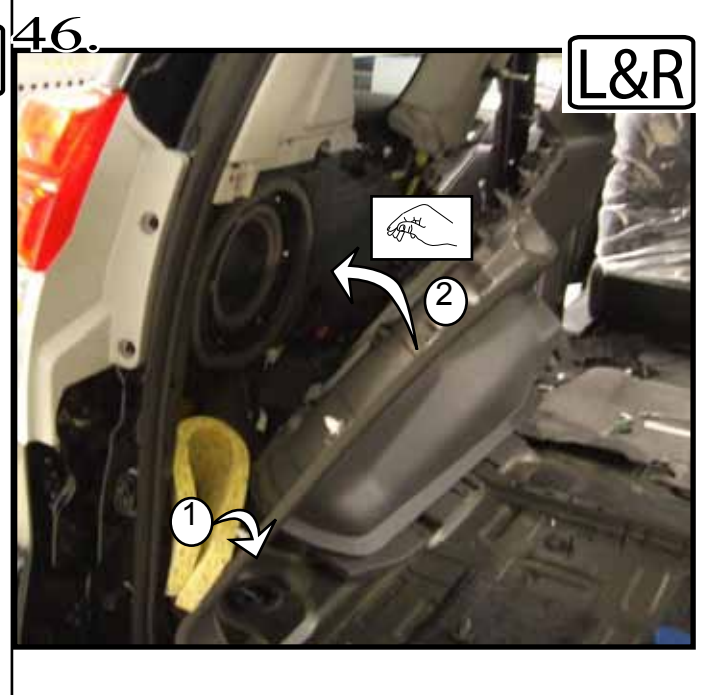
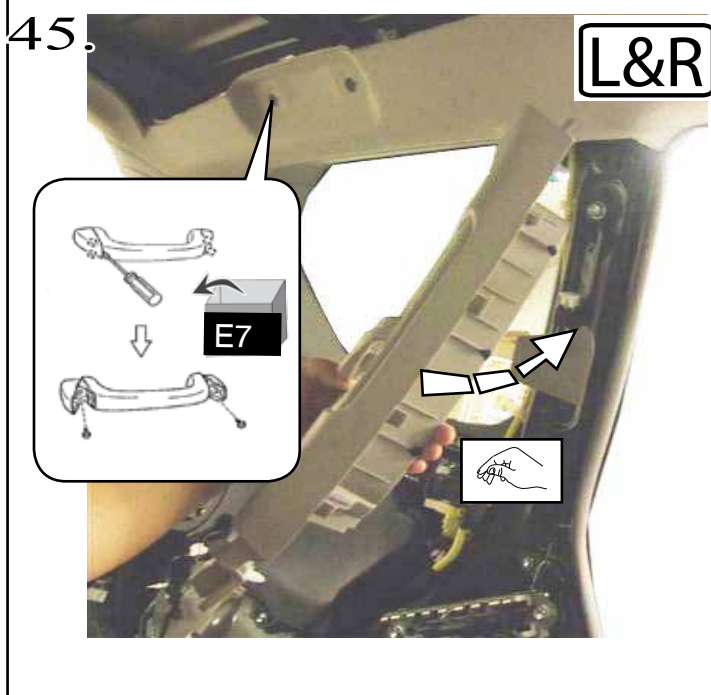
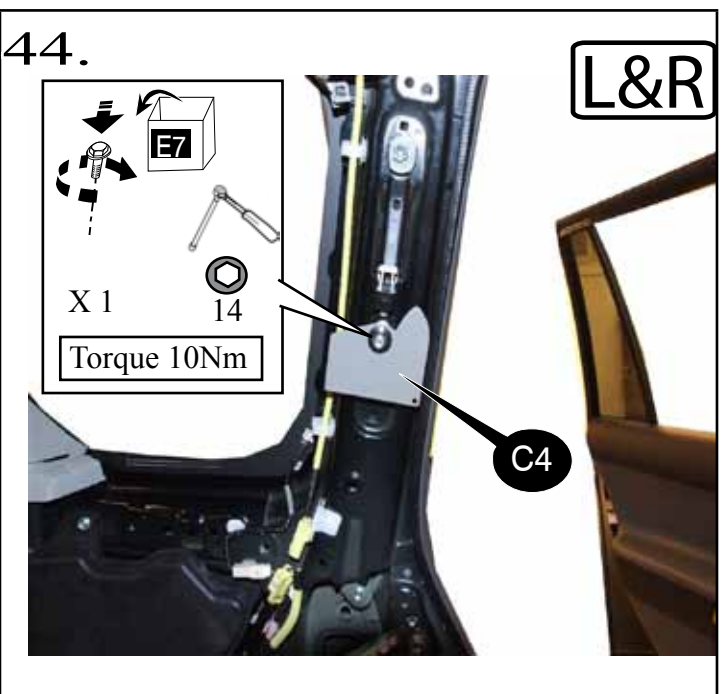
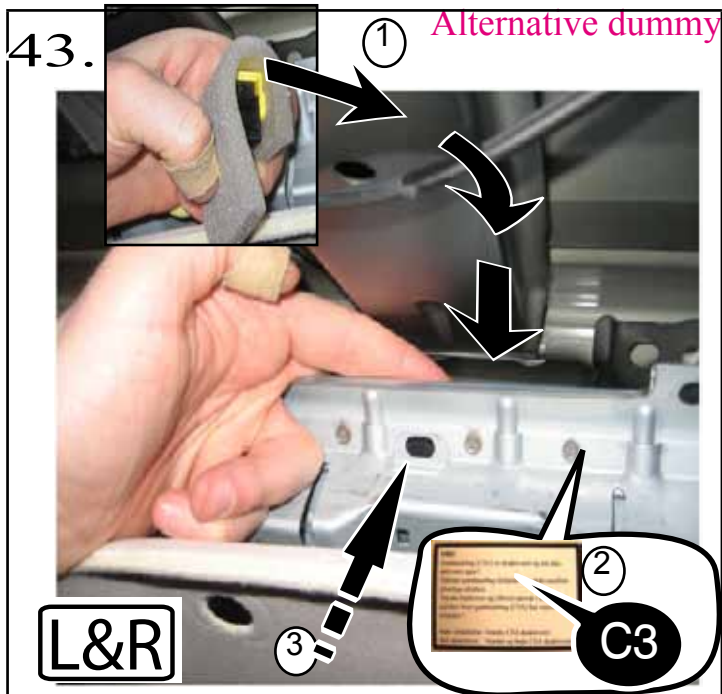

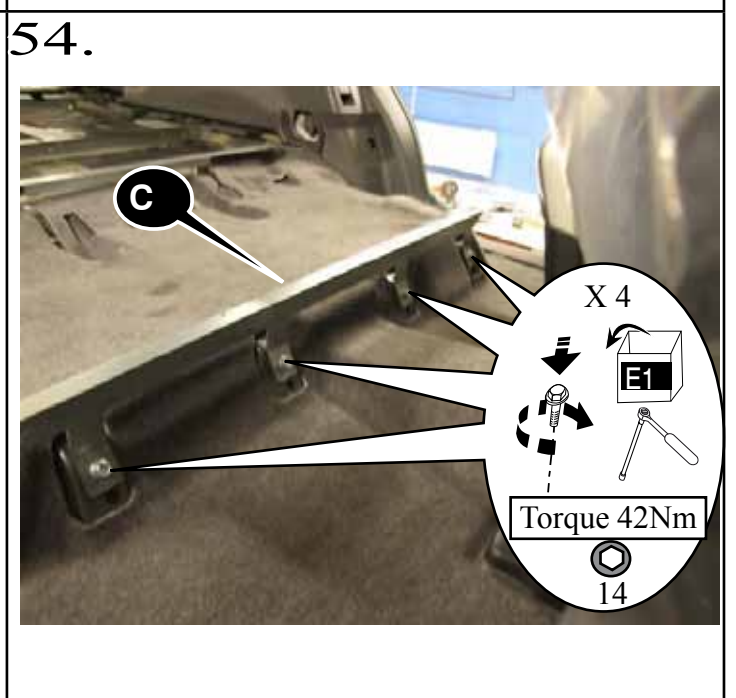
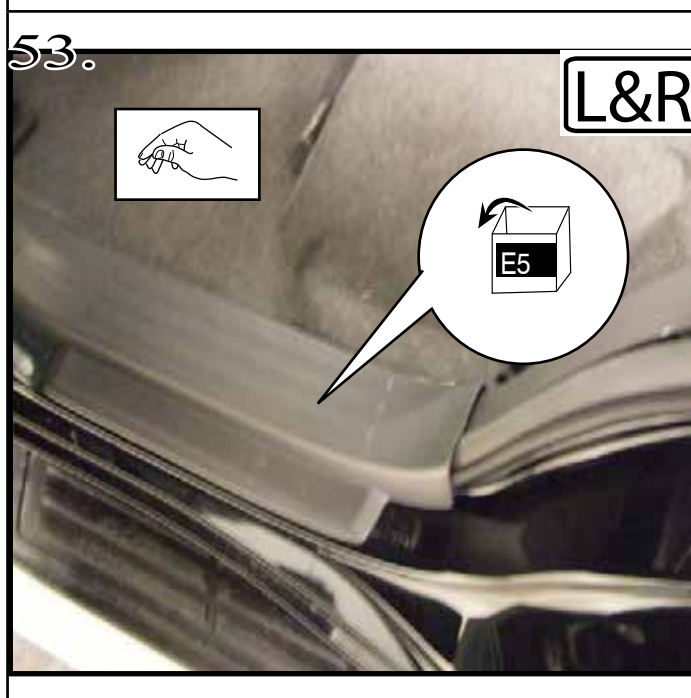
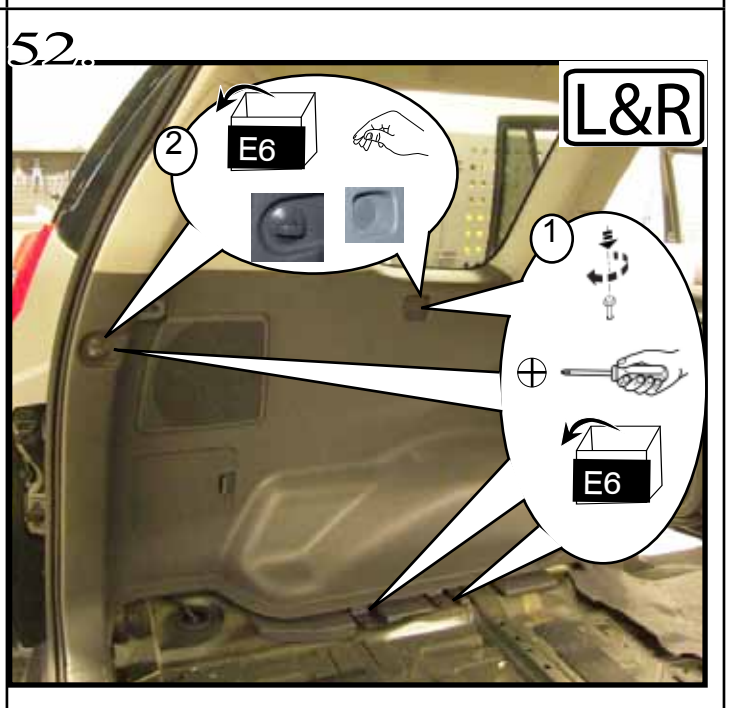
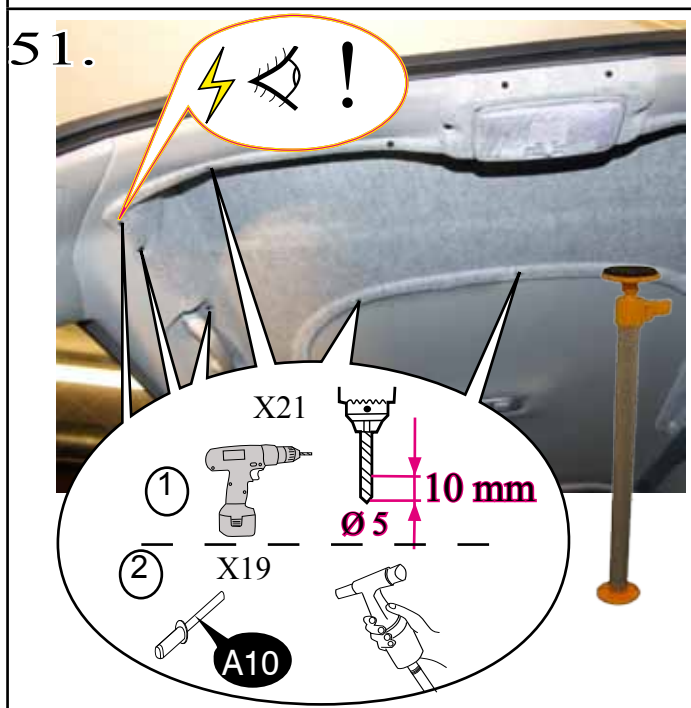
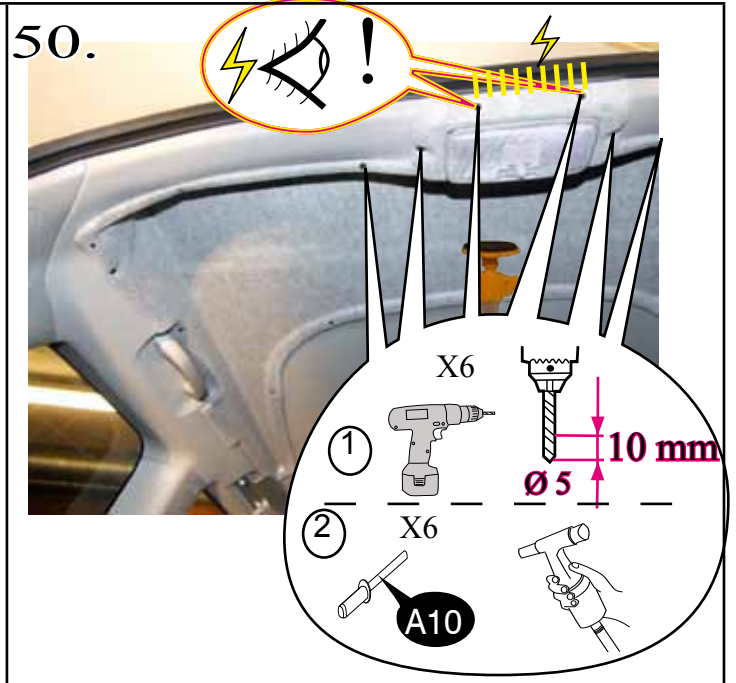
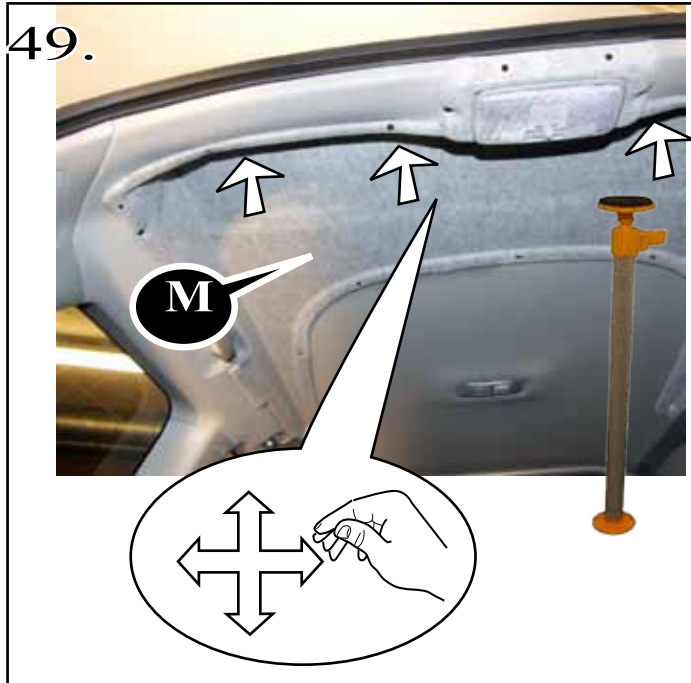

55.

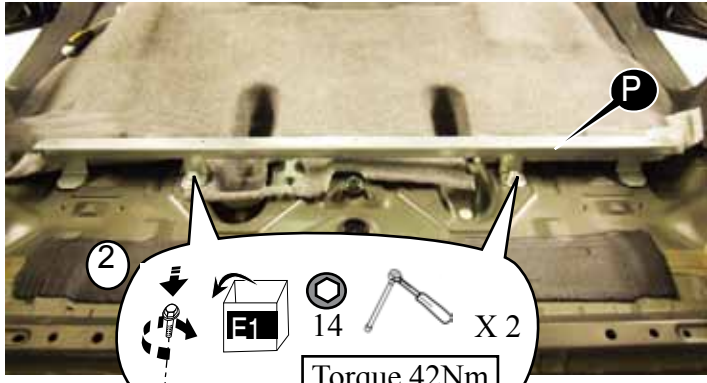
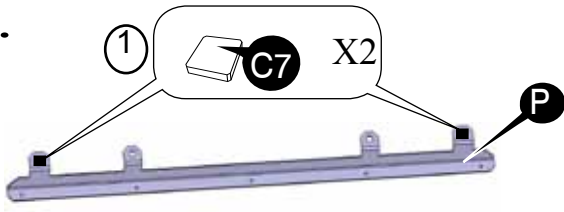

56.

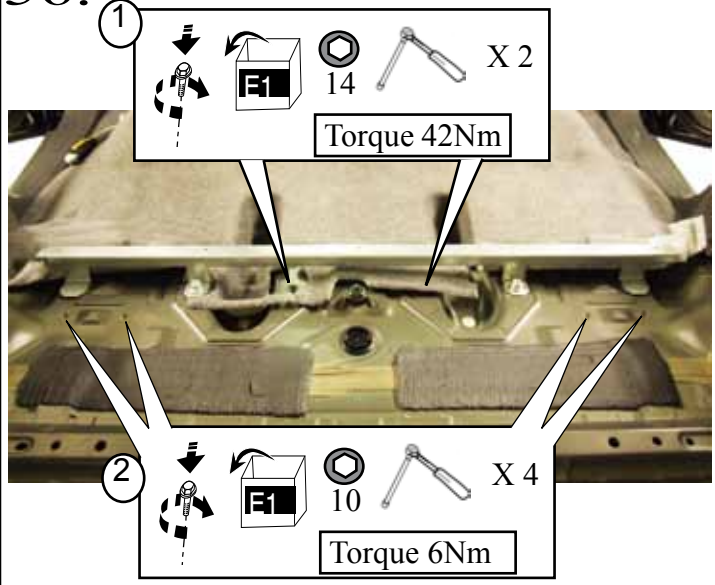

57.

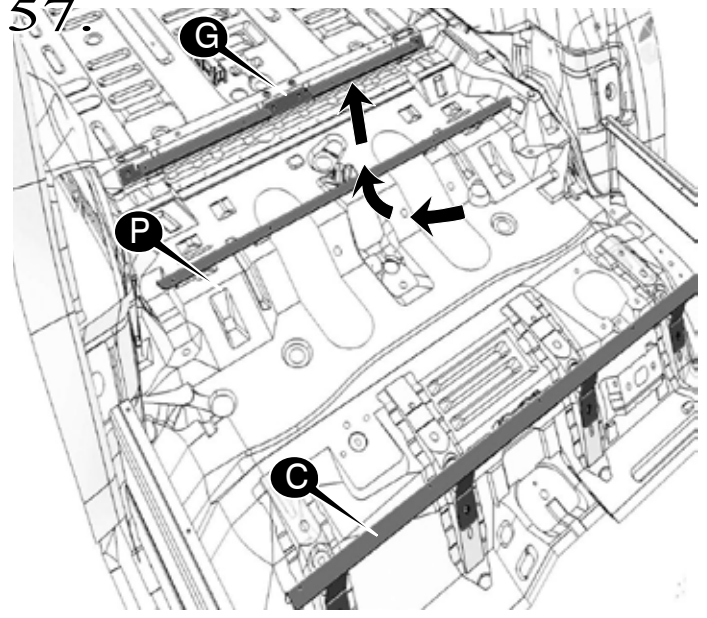

58.

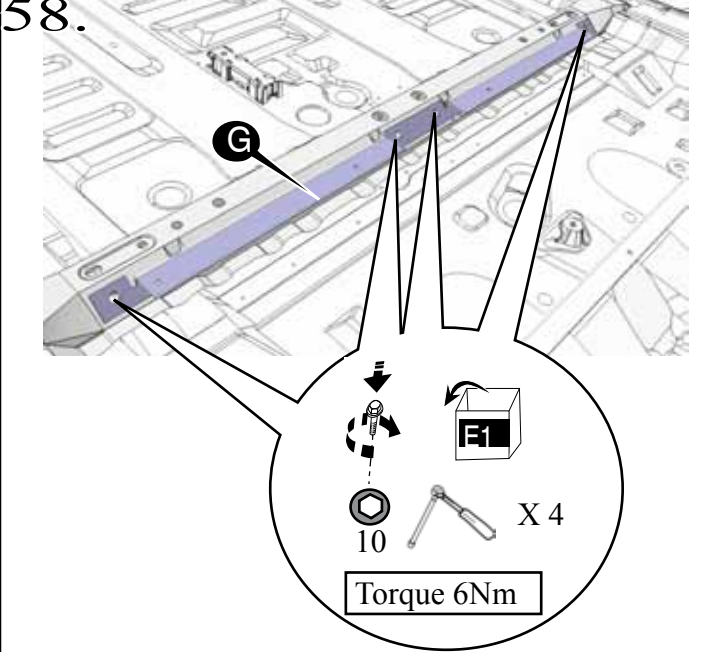

59.

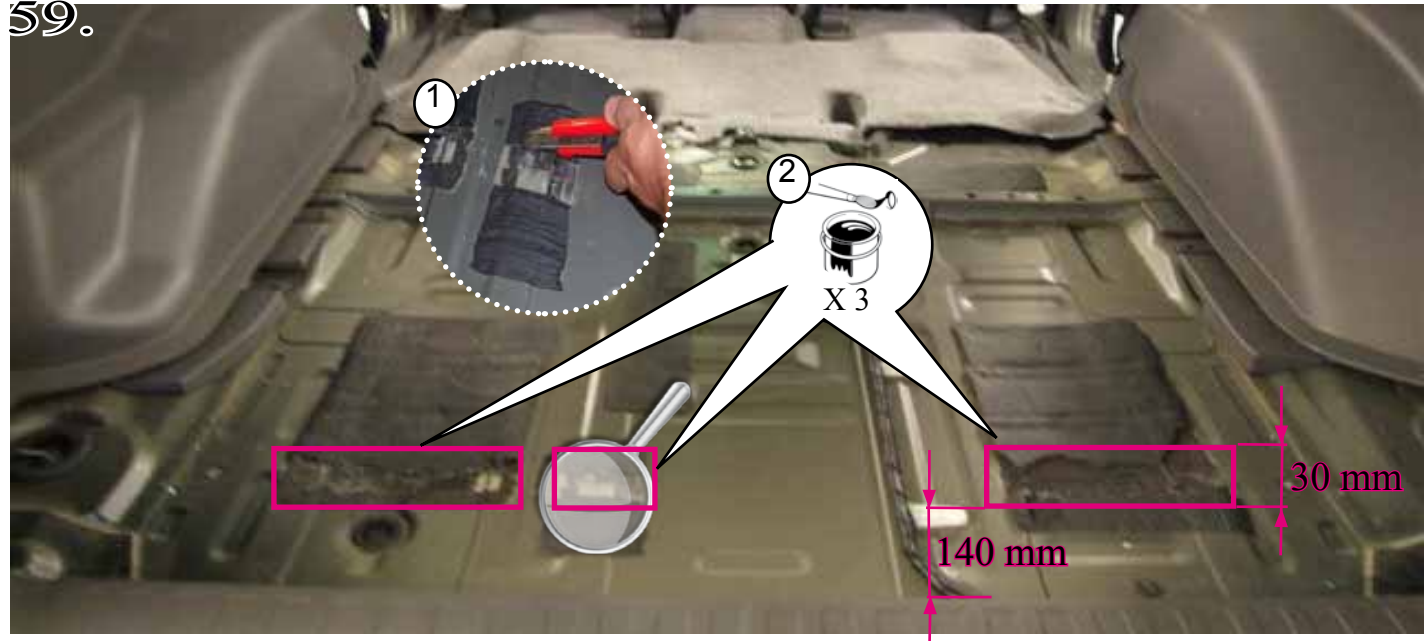

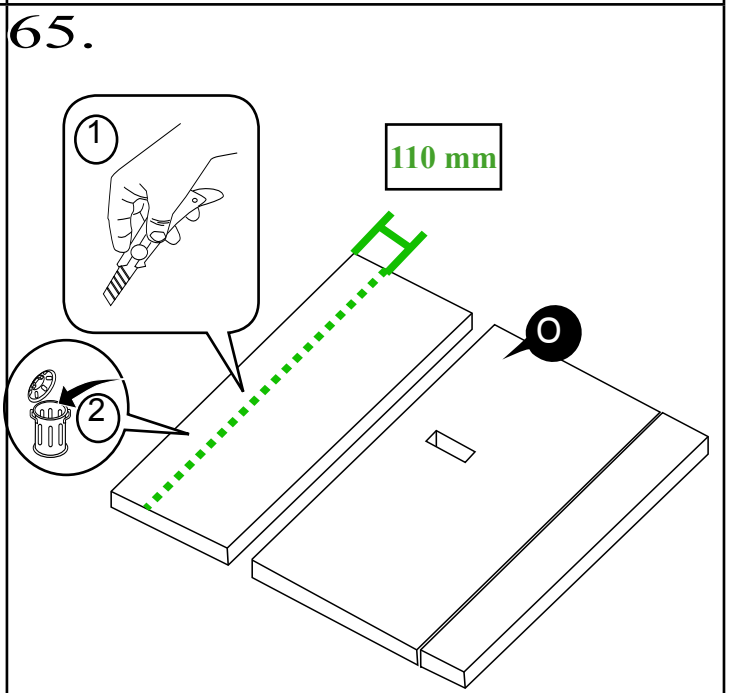
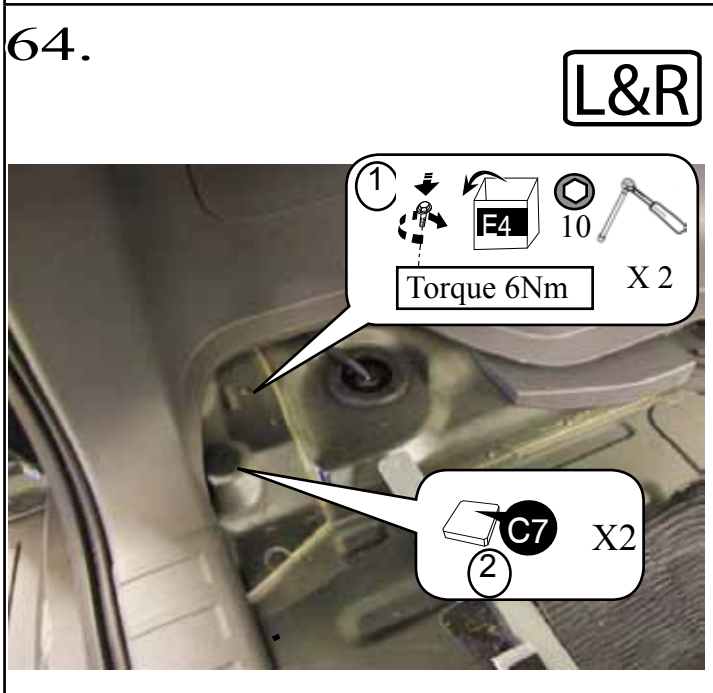
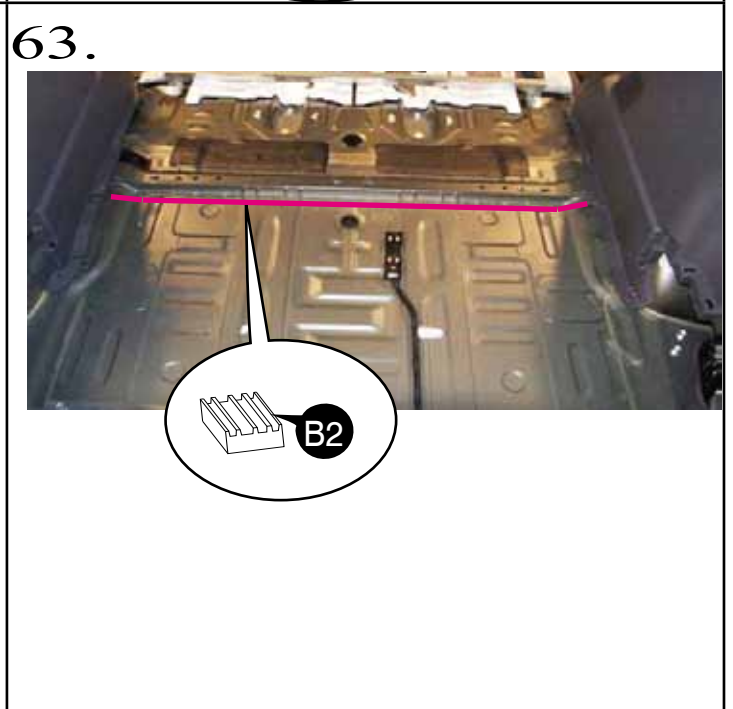
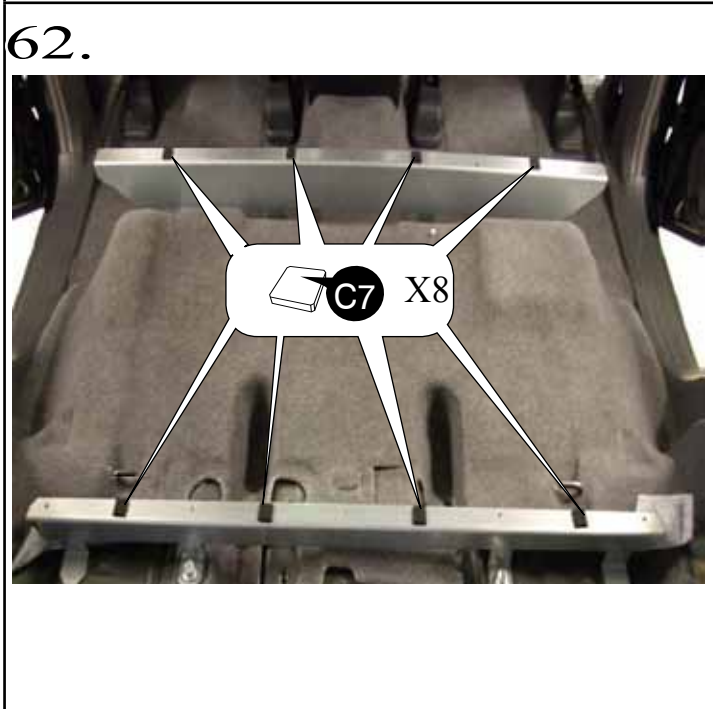
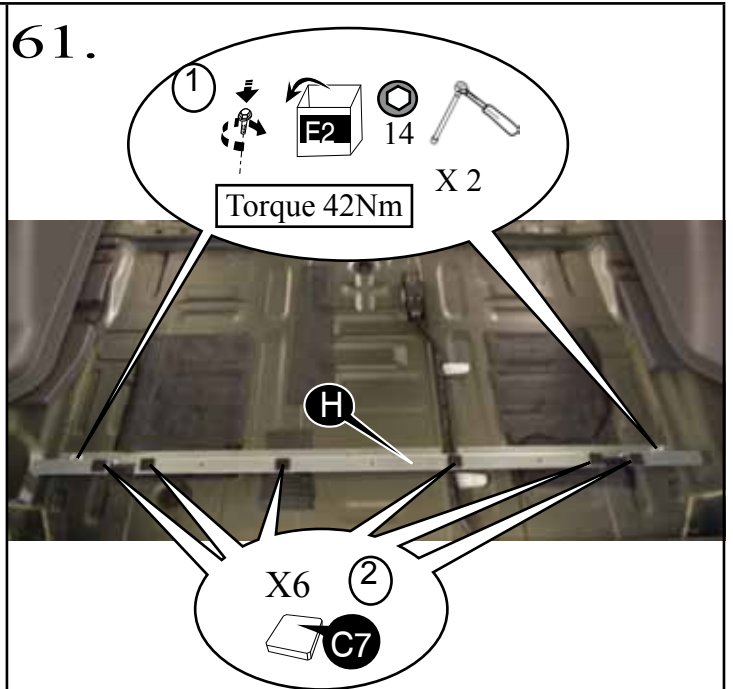
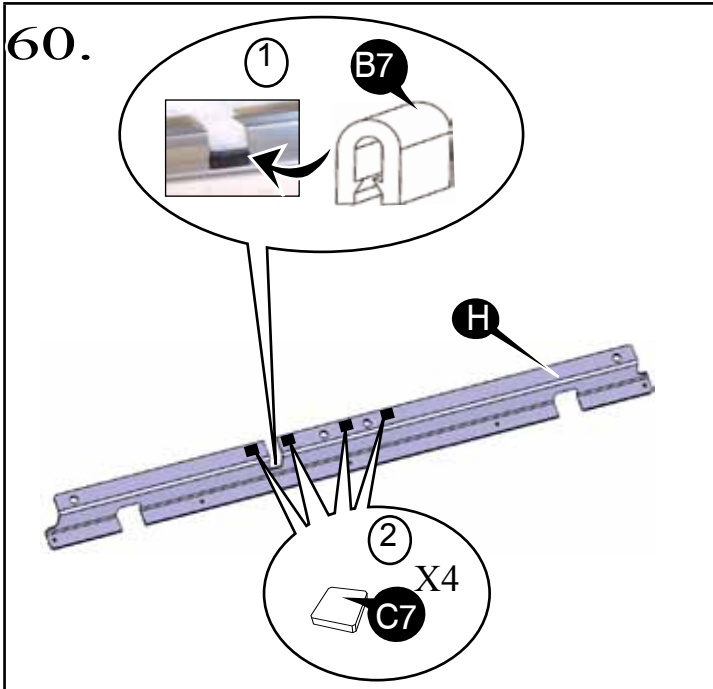

66.

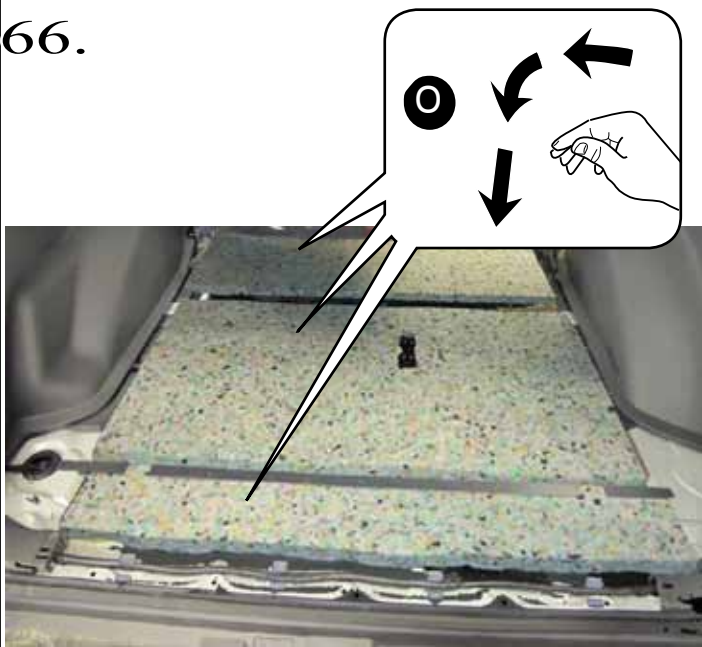

67.

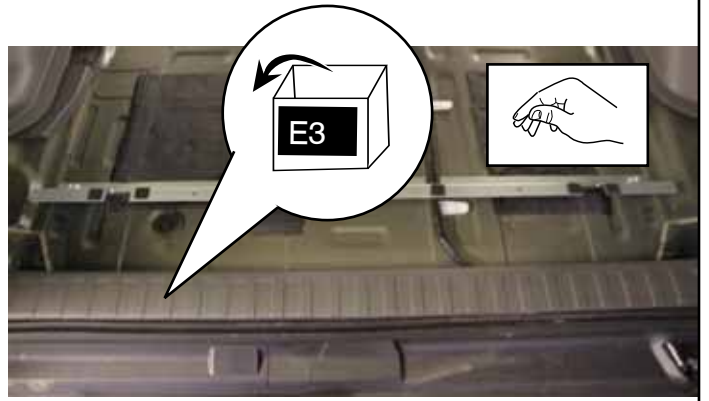

68.

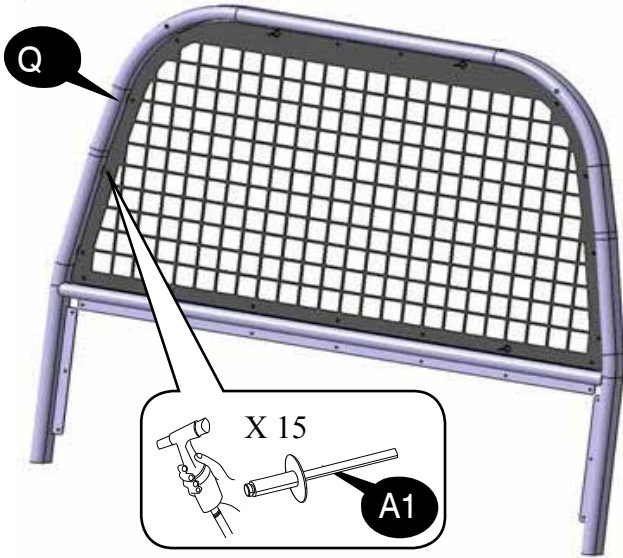

69.

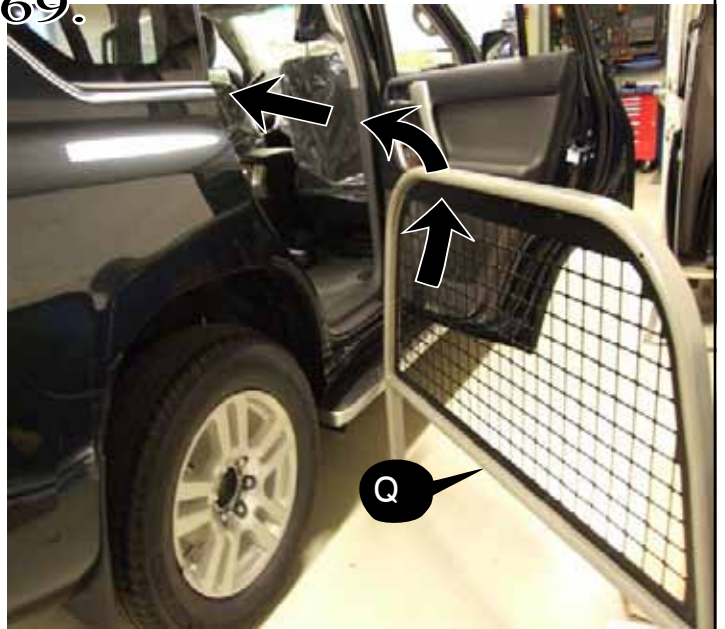

70.



71.

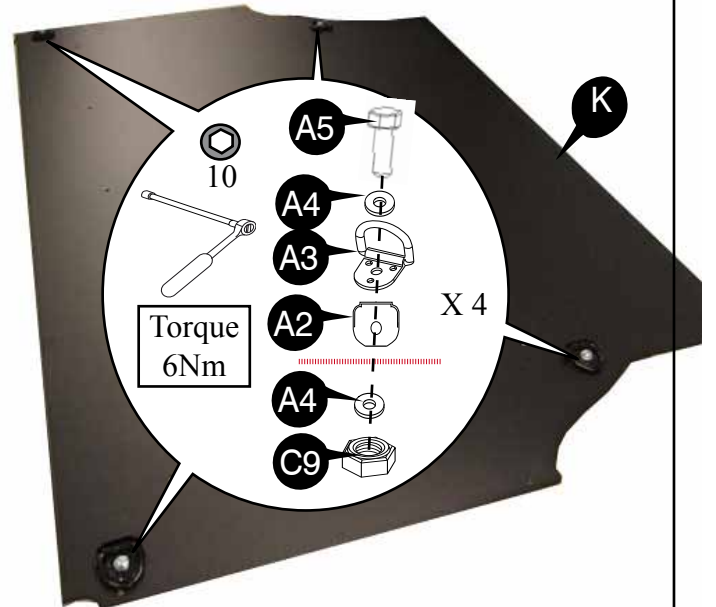

72.

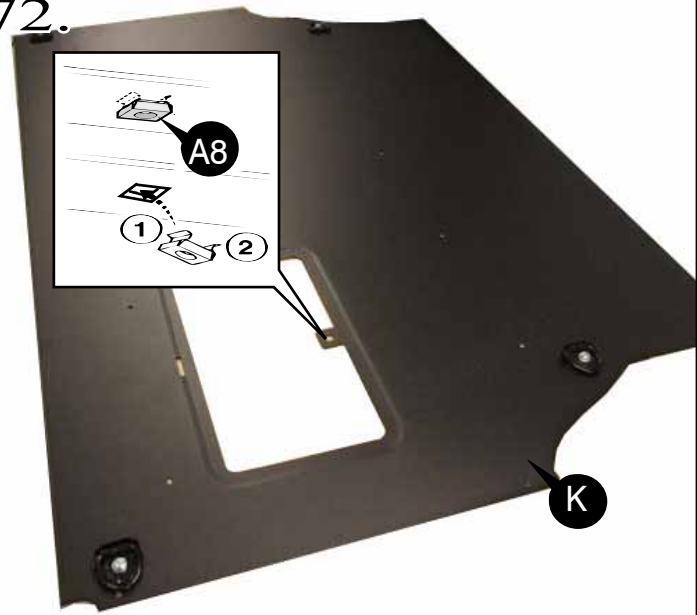

73.

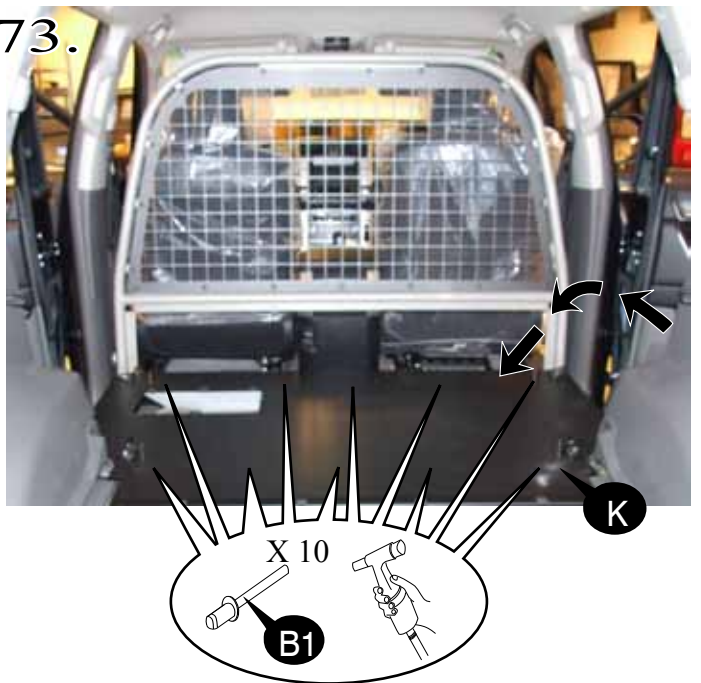

74.

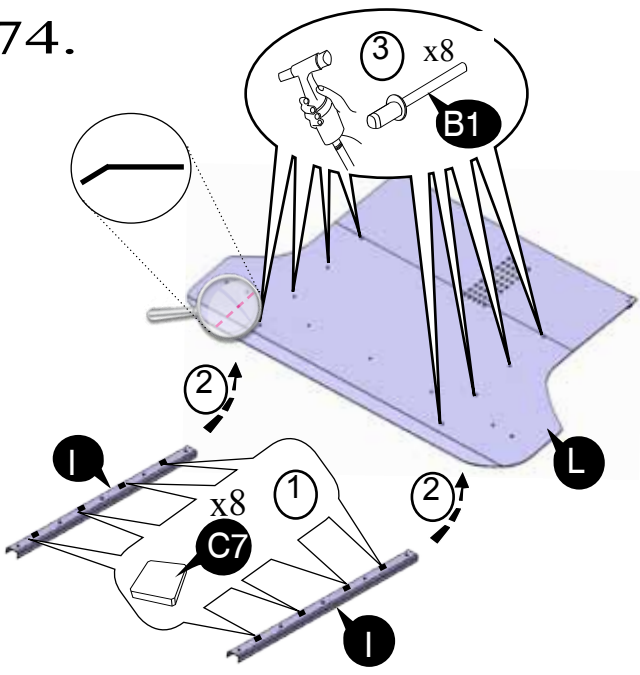

75.

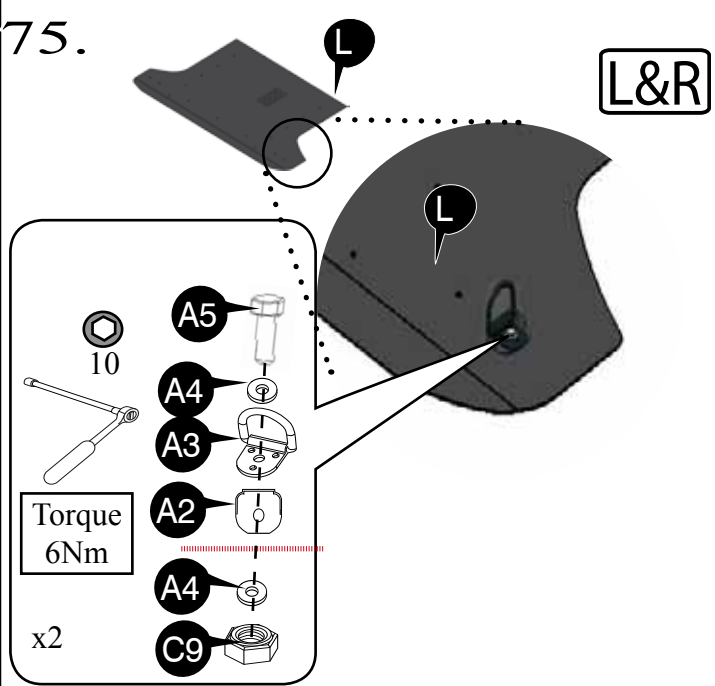

76.

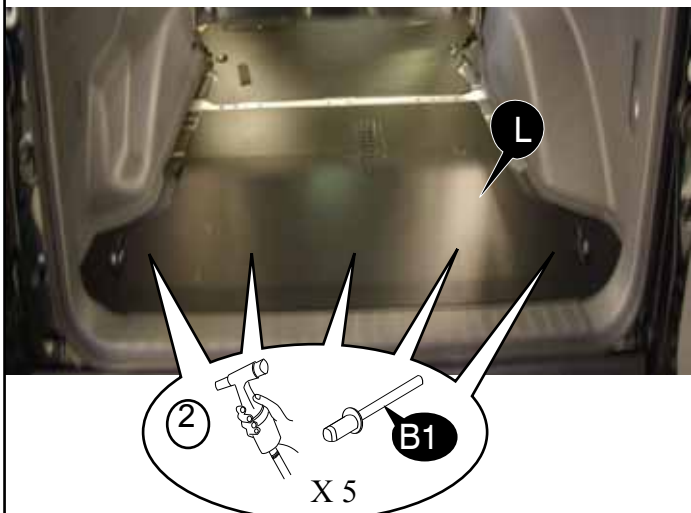

77.

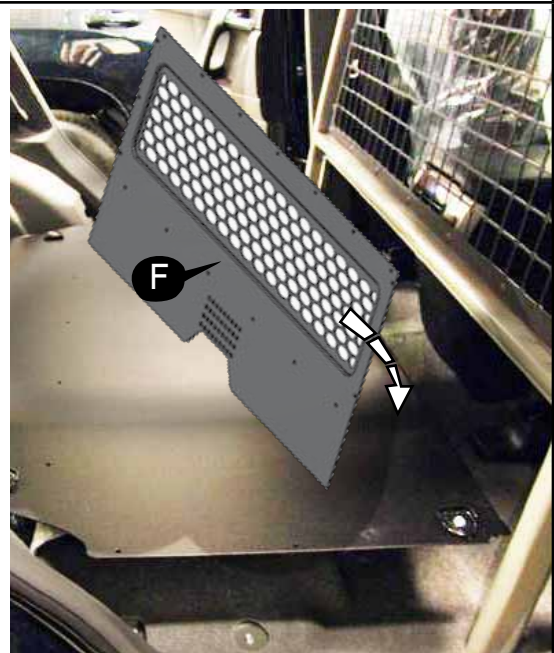

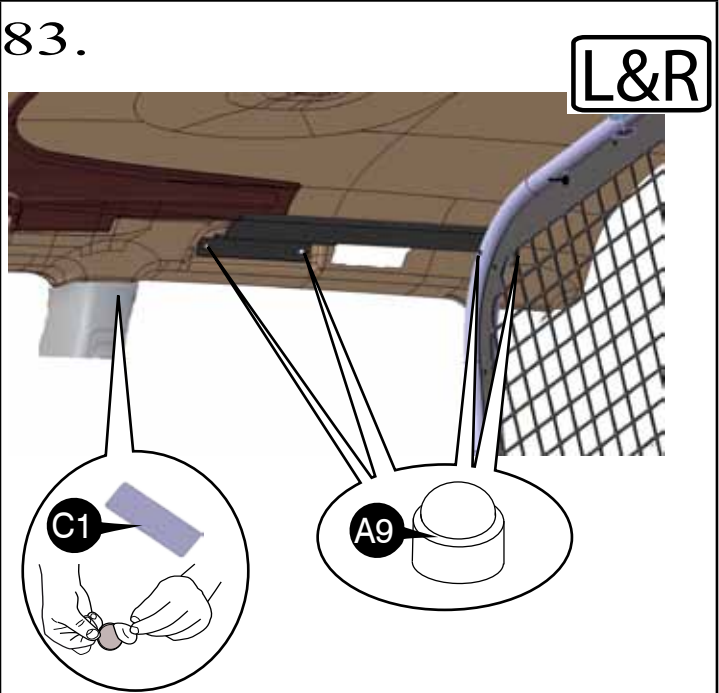
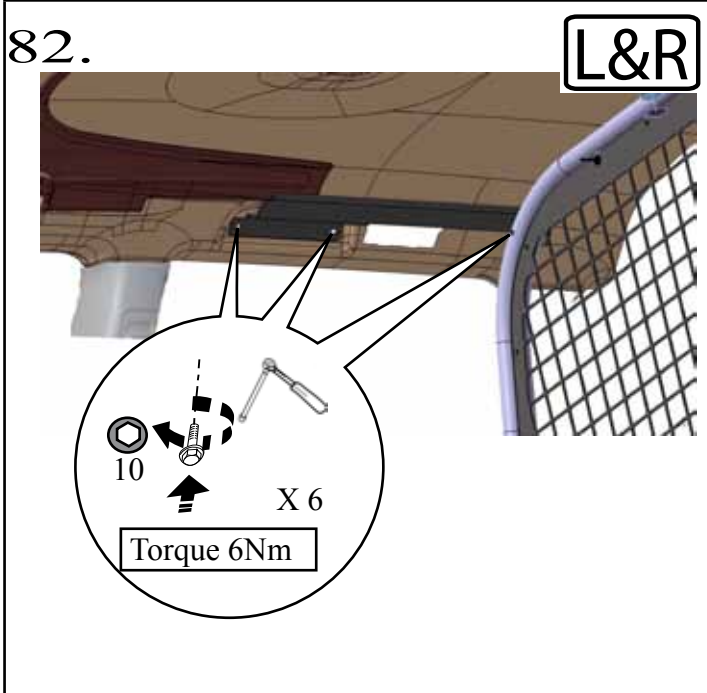
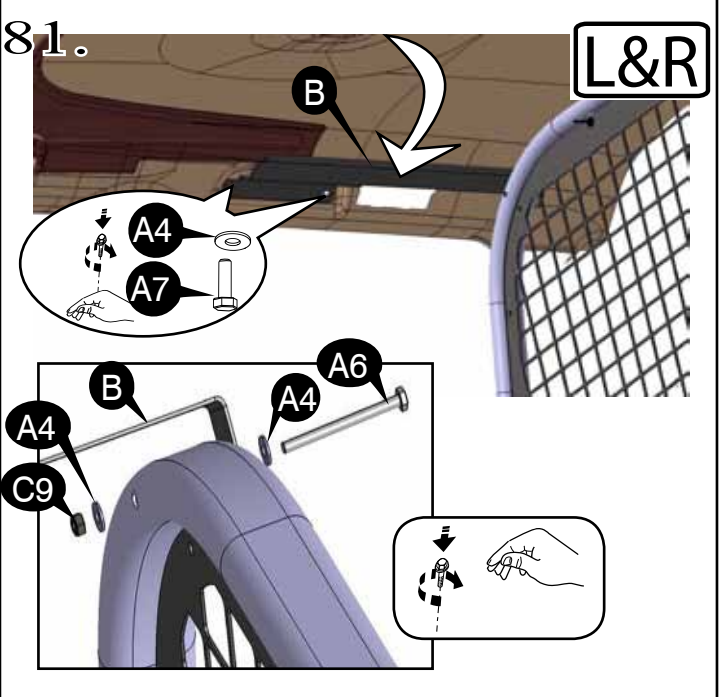
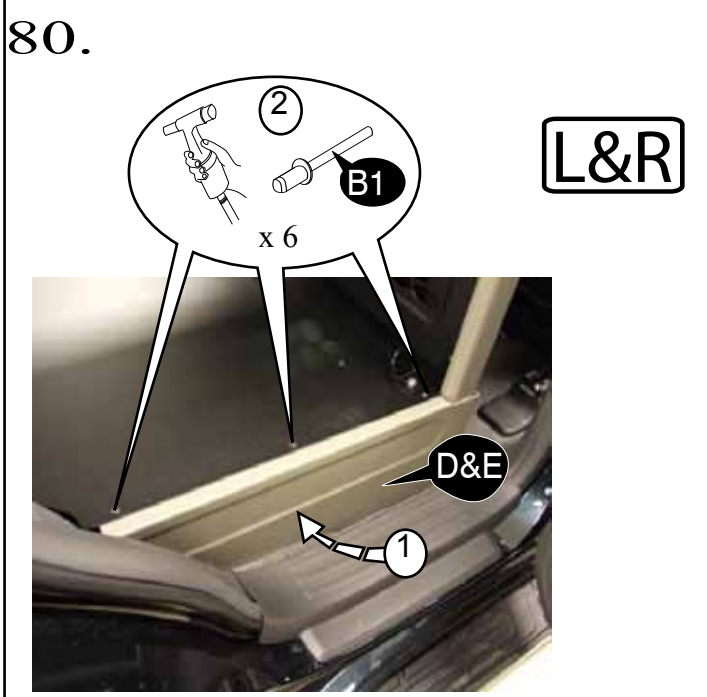
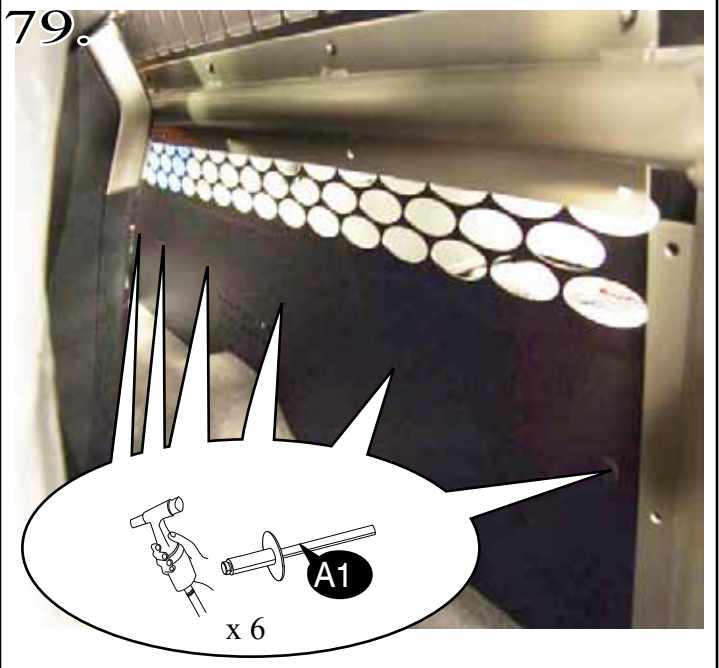
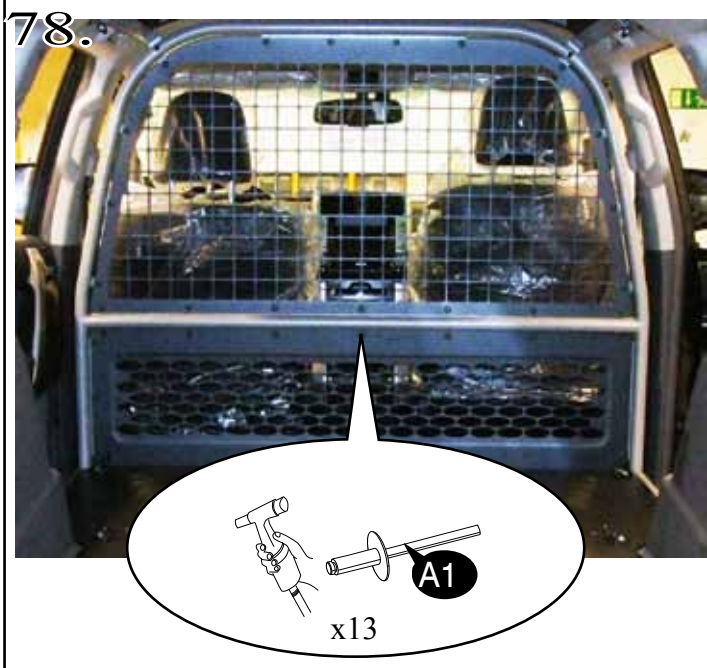

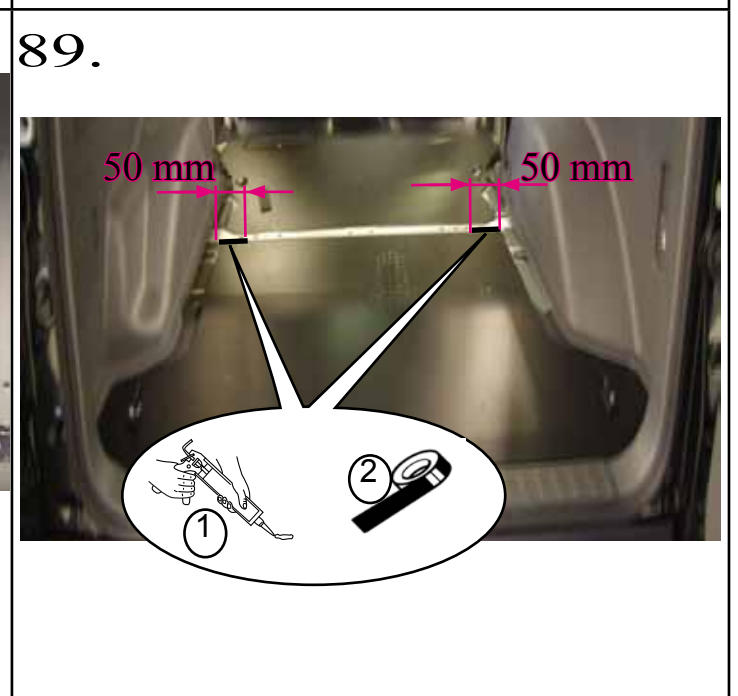
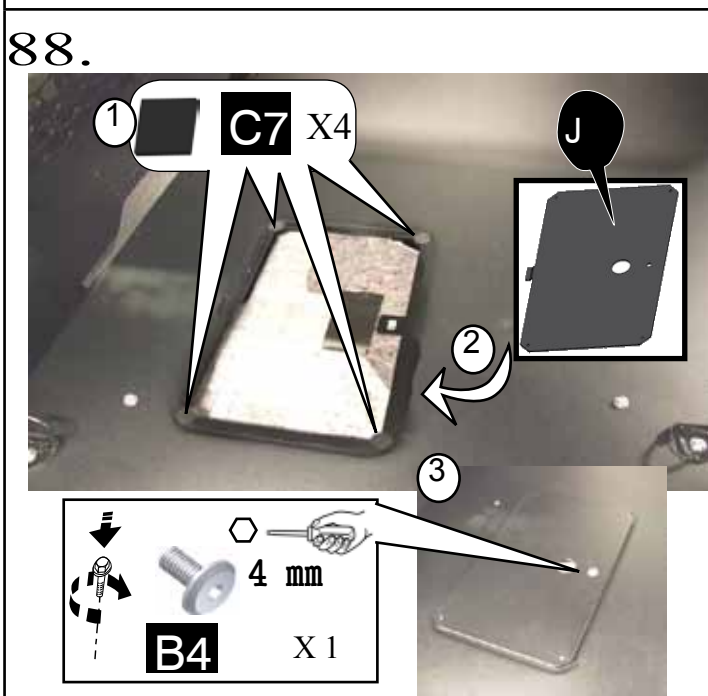
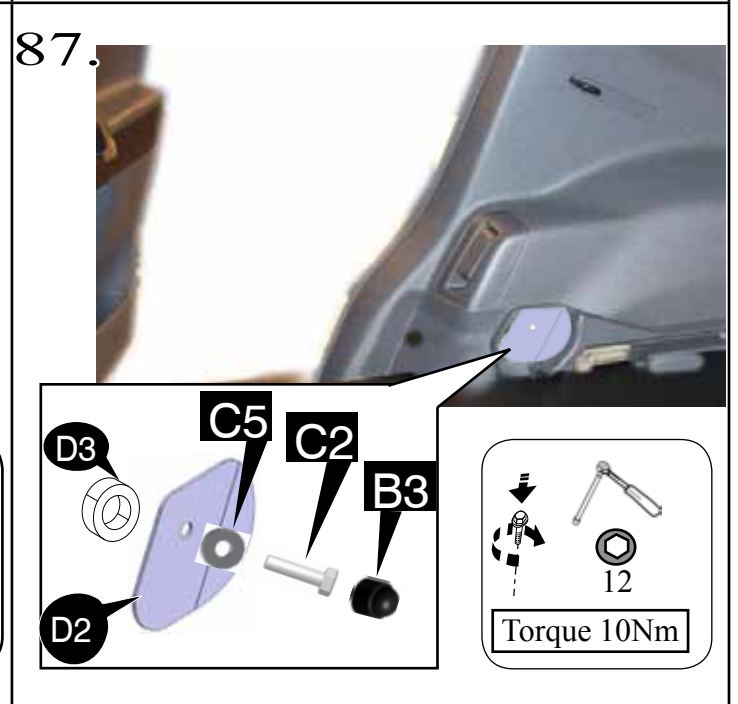
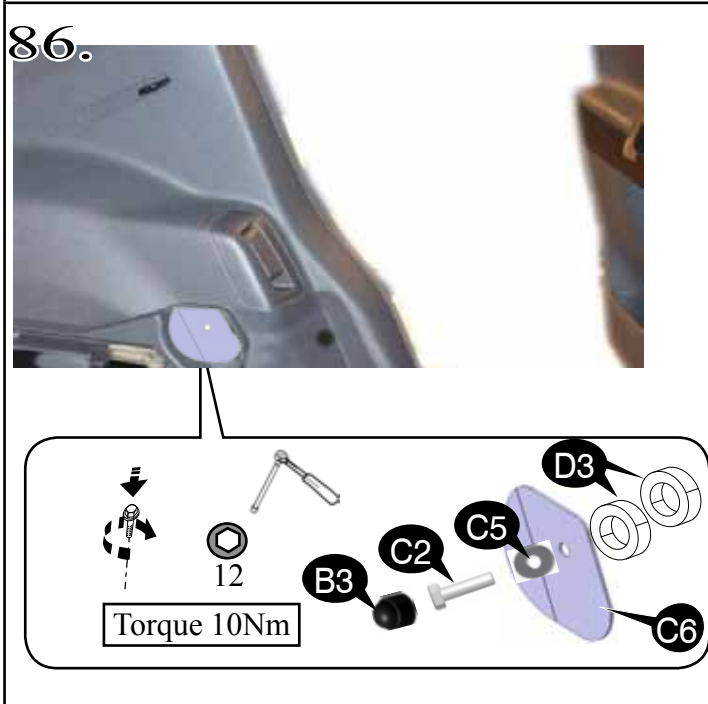
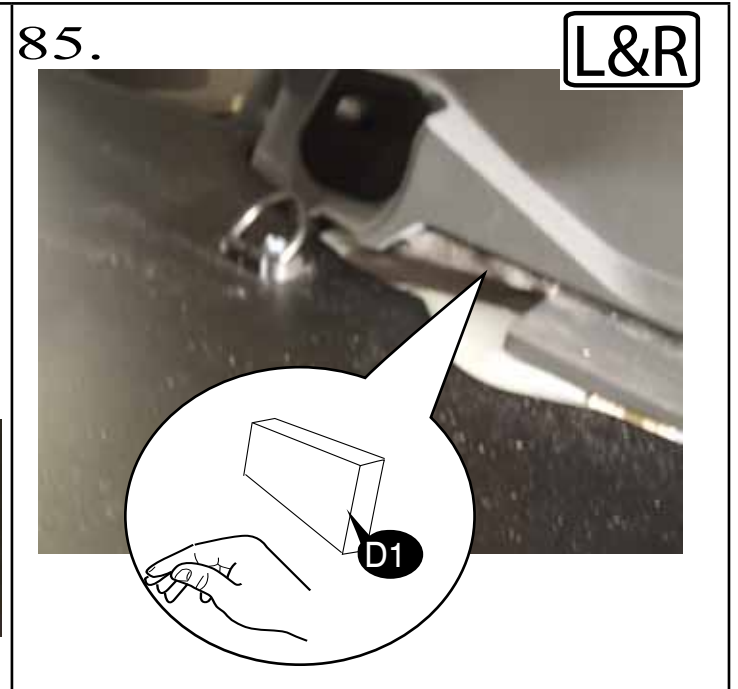
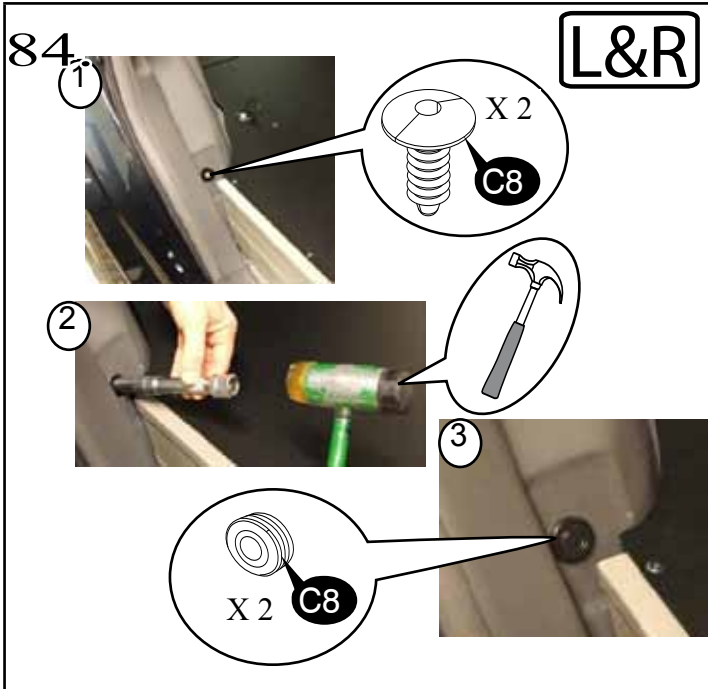

90.



91.

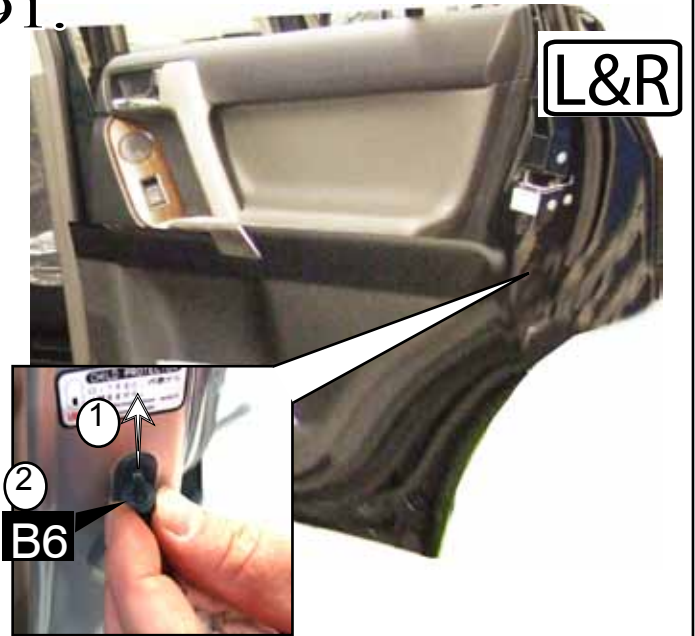

92.



CHECK SHEET



TOYOTA

Model / Year LC150 2017/08

N1 Conversion
kit TNO

VIN n°

ALWAYS A
BETTER WAY

P/N = OK

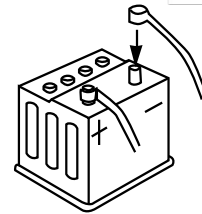

5,4 Nm
x2

CLICK

Serial Number

=A

=B

ON → OFF

A B

X 3



L&R

CLICK

Serial Number

[]

2x

6 Nm

L&R

CLICK

Serial Number

[]

6x

6 Nm

L&R

= OK

= OK

Installation Date:

[] / [] / []

Technician Name & Signature:

[]

Stamp:

[]