



TOYOTA

ALWAYS A
BETTER WAY

Toyota C-HR

Side steps

Installation instructions

Model year: As from 2016/10

Vehicle code: MAXH10*-AHX*BW
X*-AH****

Part number: PW388-10001

Manual reference number: AIM 003 929-6

Revision Record

Rev. No.	Date	Page	Picture	Update	New	Deleted steps
1	20.12.16	11	19	X		
1	20.12.16	13	23	X		
1	20.12.16	16		X		
2	02.05.18	1		X		

Rev. No.	Date	Page	Step	Remarks
	06.08.19	10-14	14-25	Tightening sequence changed
	06.08.19	15, 16	C/S	CheckSheet updated
	03.12.19	1, 20	C/S	Model year added
	03.12.19	5, 19	4, 30	Step updated
	03.12.19	6, 7, 9, 18	7, 8, 10, 29	Step added
	07.01.20	1		Vehicle codes added
	07.01.20	9, 10	10, 11	Drawing updated of undercover
	09.06.20	2		Tool diameter updated from Ø32 mm to Ø35 mm
	09.06.20	4, 7, 8, 11, 16, 18, 19	1, 8, 9, 13, 26, 29, 30	Warning Symbol removed
	09.06.20	11	13	Tool diameter updated from Ø32 mm to Ø35 mm

 13 mm 17 mm				
 Ø3 mm Ø9 mm Cobalt drill bit	 Ø 35 mm			

PW388-10006 (LHS)

A

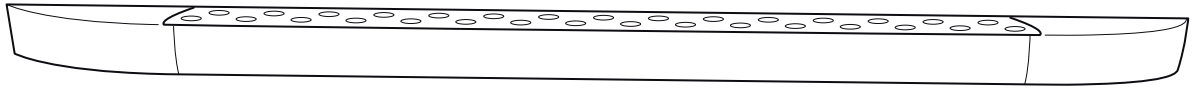

1x

PW388-10007 (RHS)

B

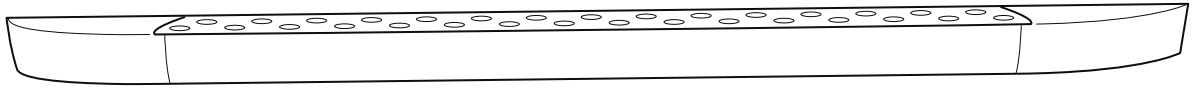

1x

PW388-10009 (RHS)

C

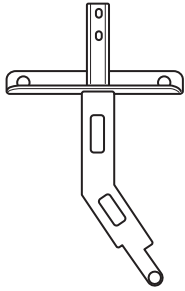

1x

D



1x

E

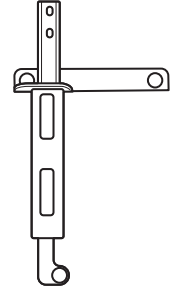

1x

J

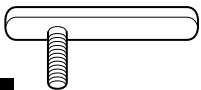

5x

K

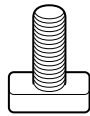

6x

L



5x

M



7x

N



2x

P

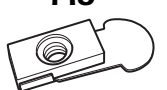

1x

Q

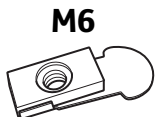

2x

R



5x

S



6x

T



1x

U



2x

V



5x

PW388-10008 (LHS)

F

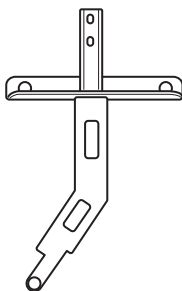

1x

G



1x

H

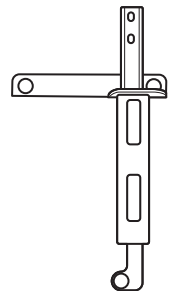

1x

J

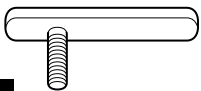

5x

K

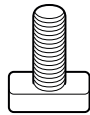

6x

L



5x

M



7x

N



2x

P

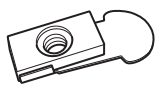

1x

Q

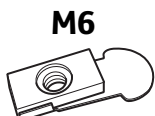

2x

R



5x

S



6x

T



1x

U



2x

V



5x

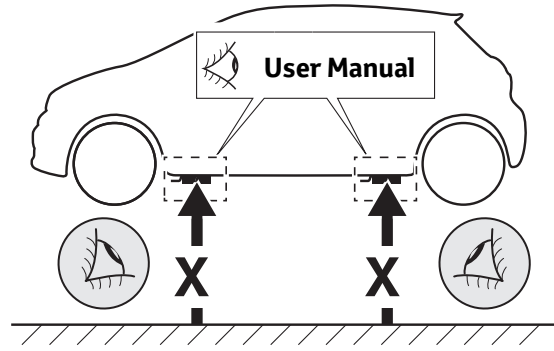
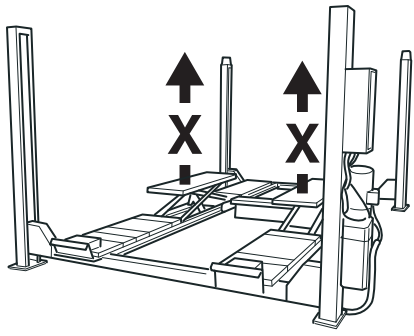

1

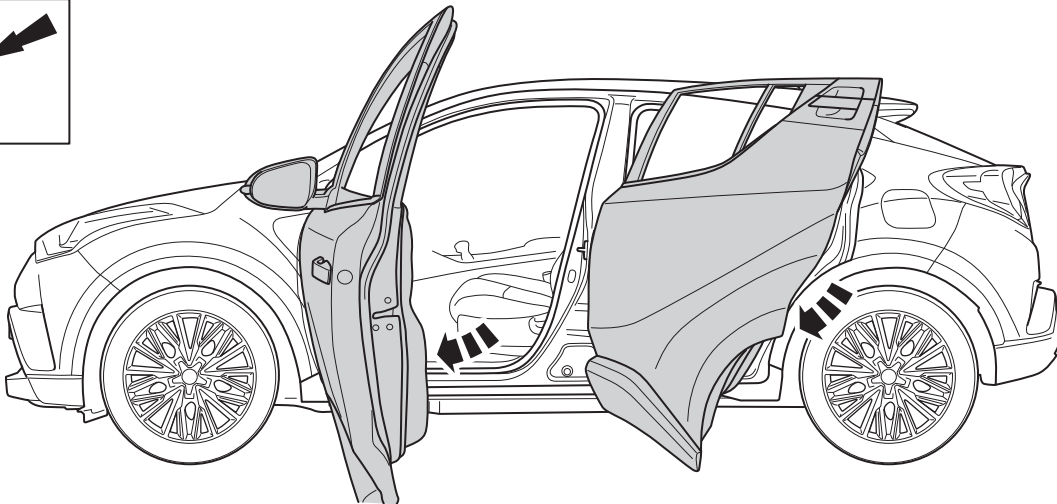
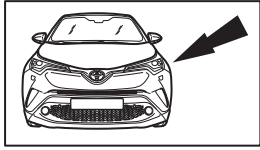

2

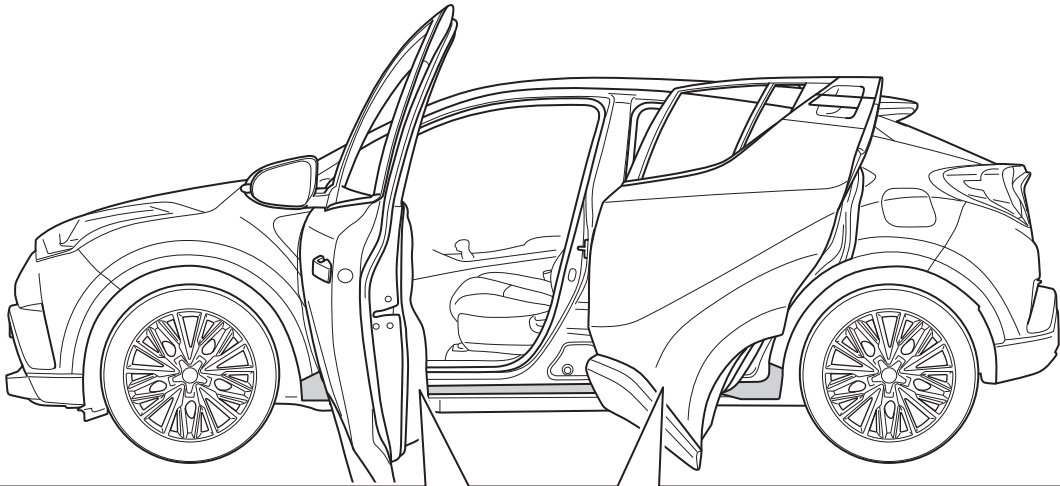
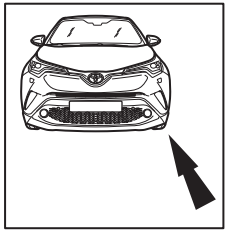

3

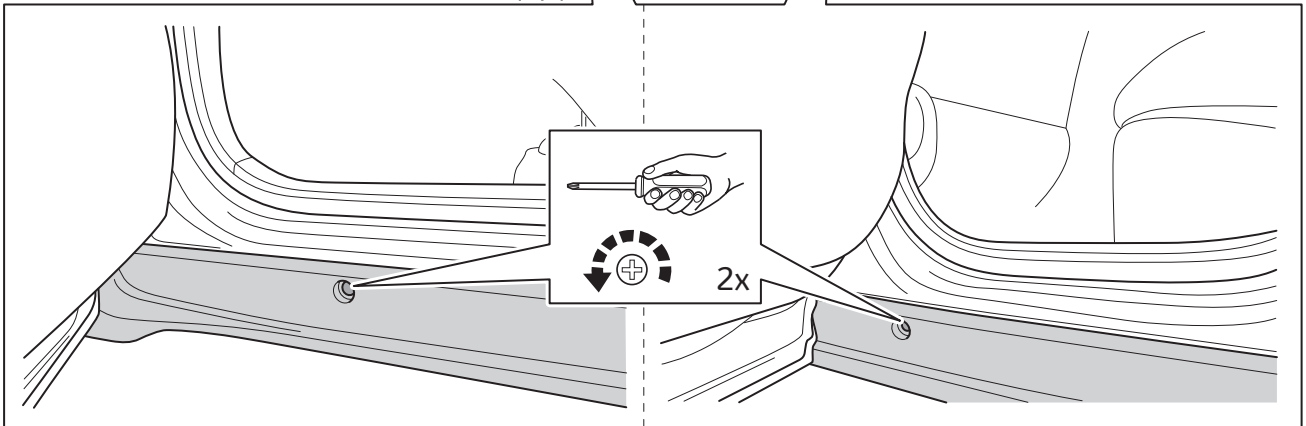

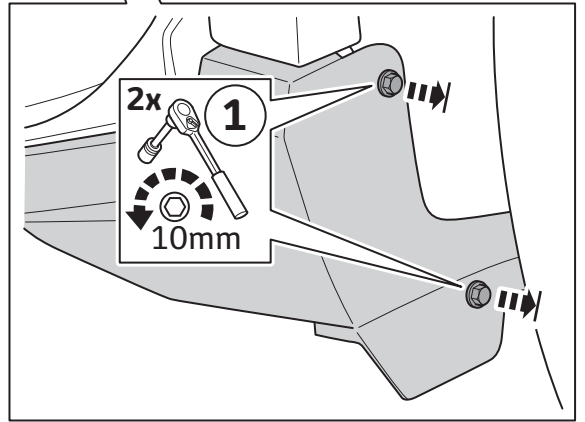
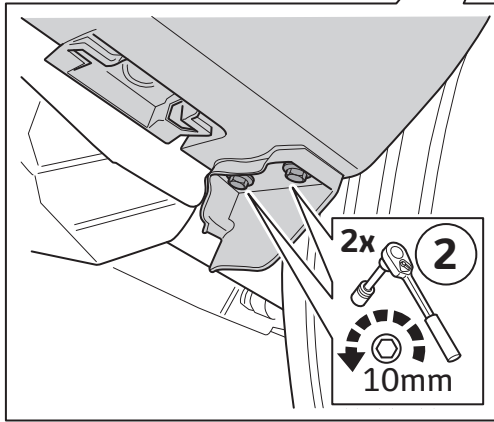
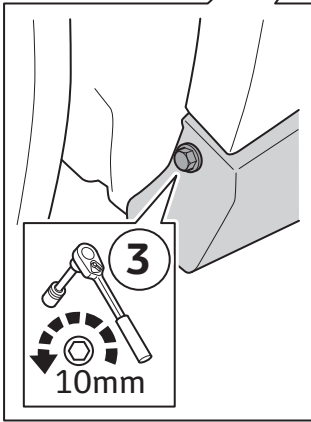
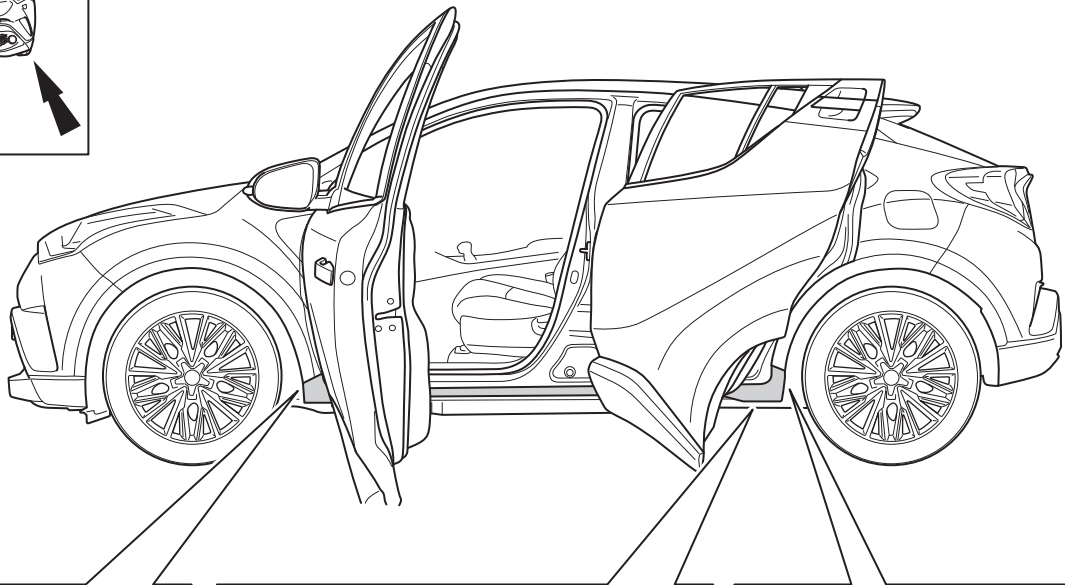
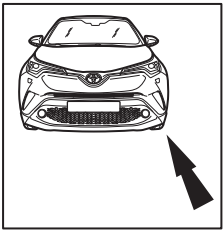

4

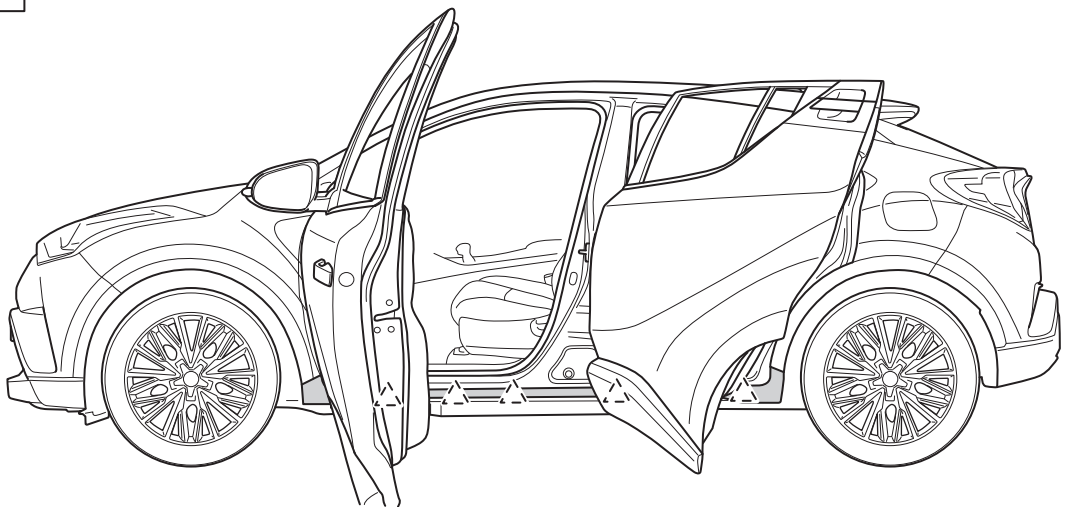
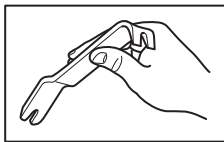
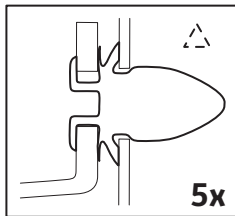
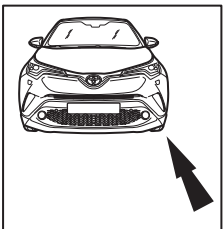

5

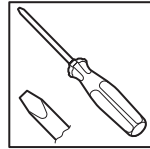
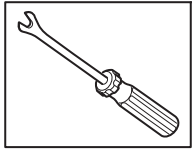
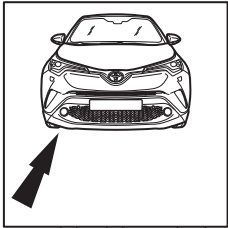

10 mm

X1

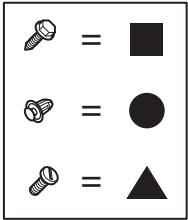
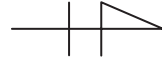

- =
- =
- =

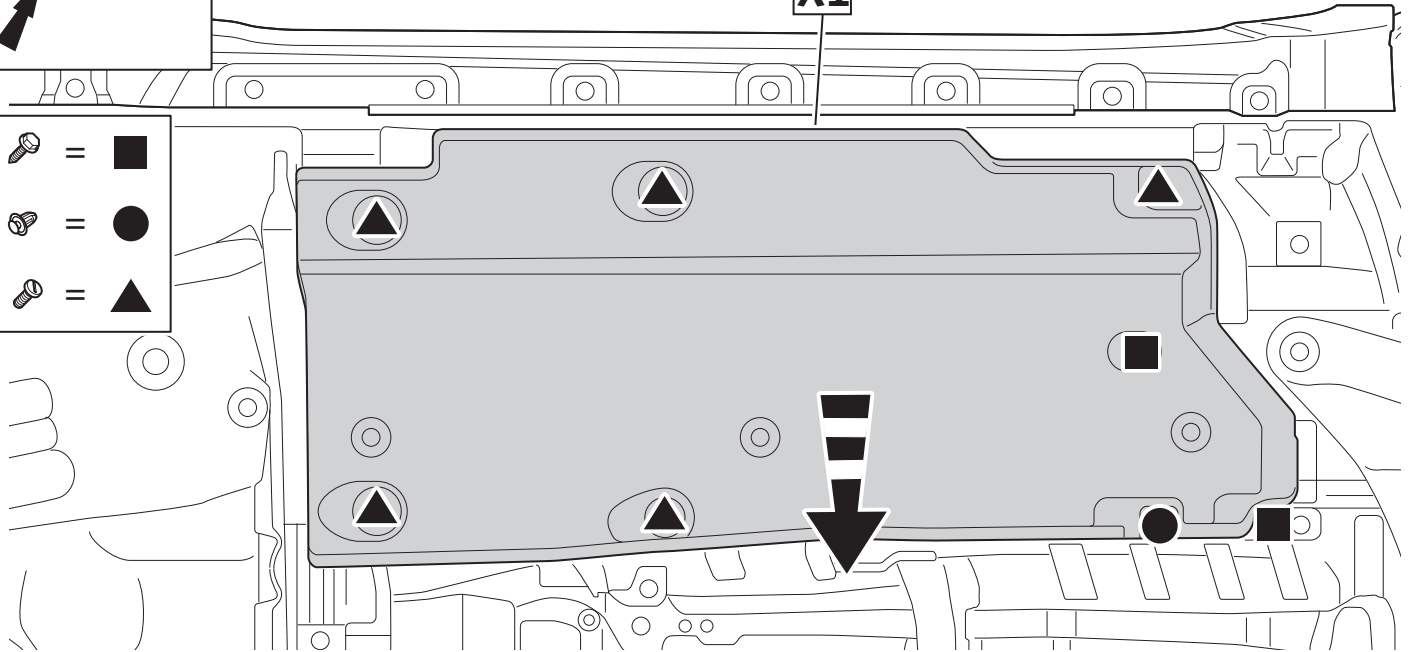

6

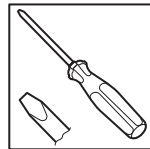
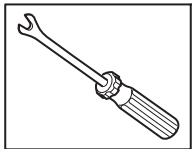
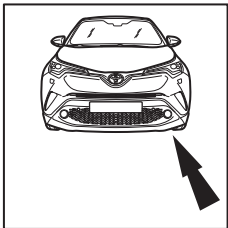

10 mm

X2

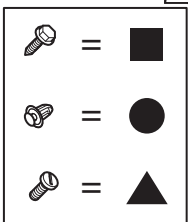

- =
- =
- =

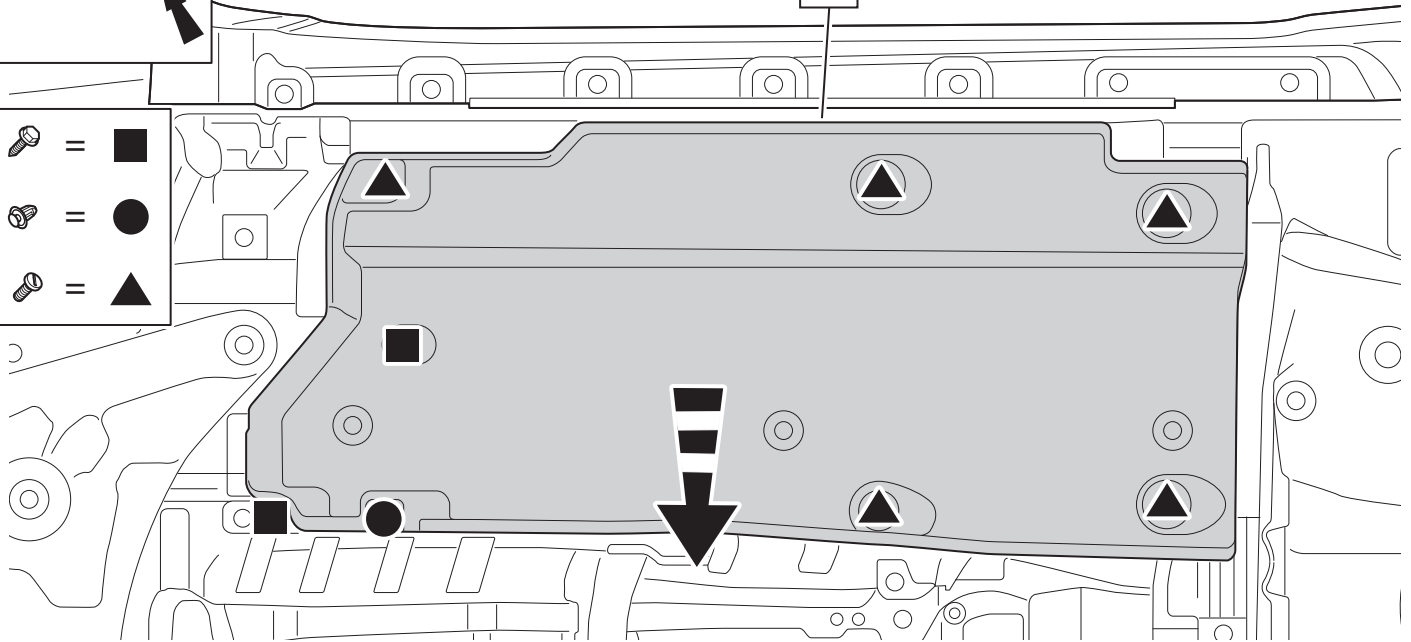

7

RHD

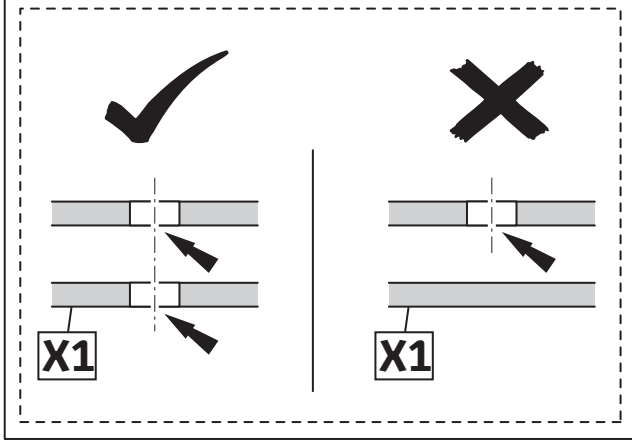
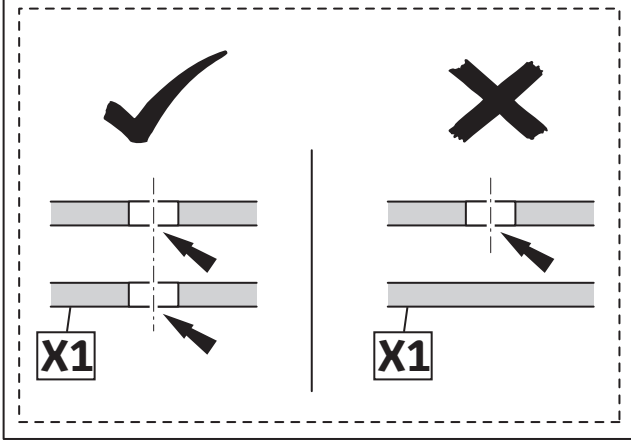
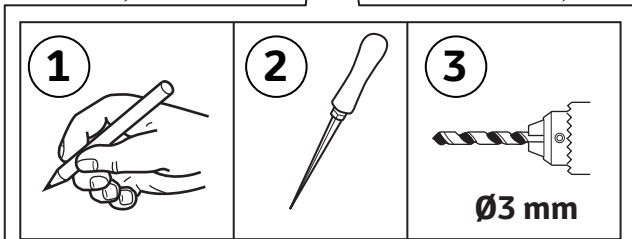
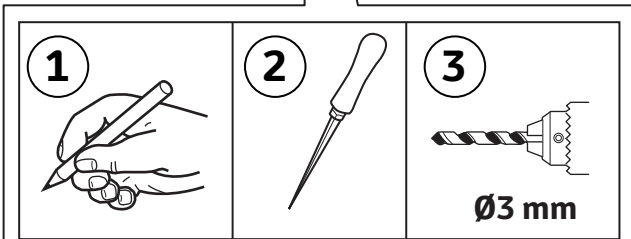
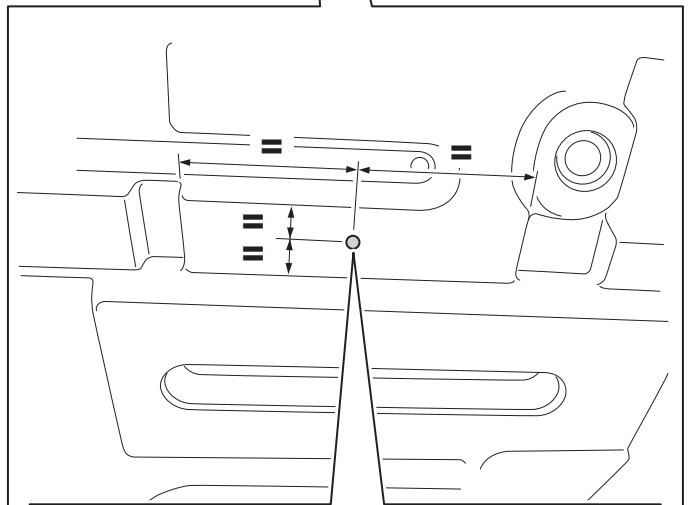
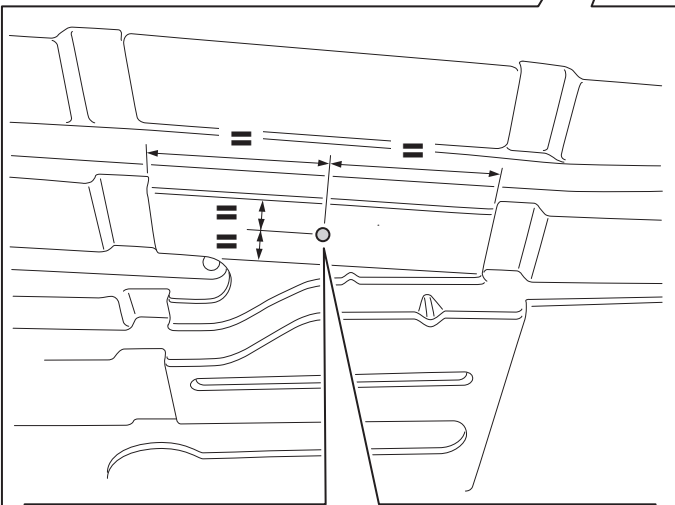
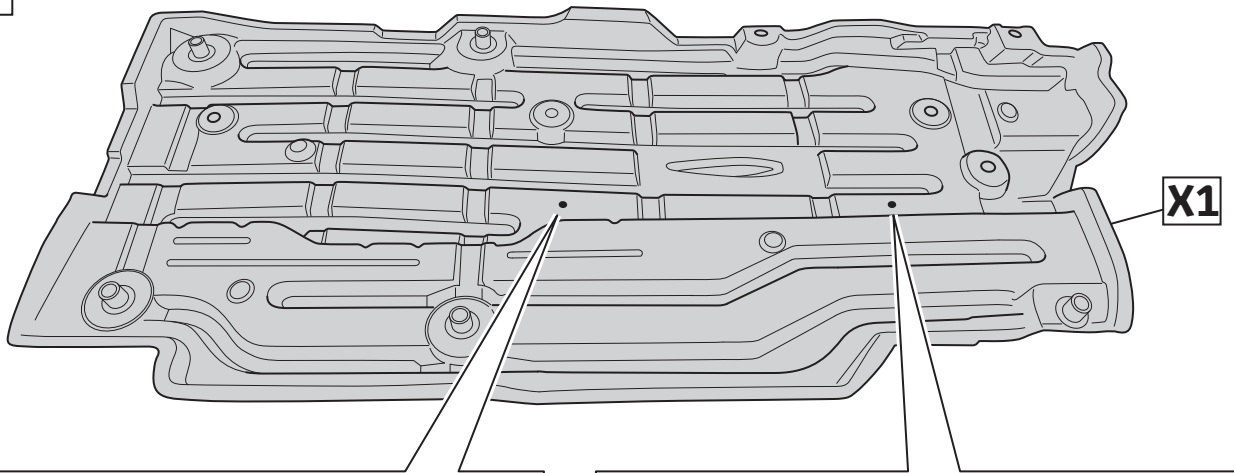

LHD

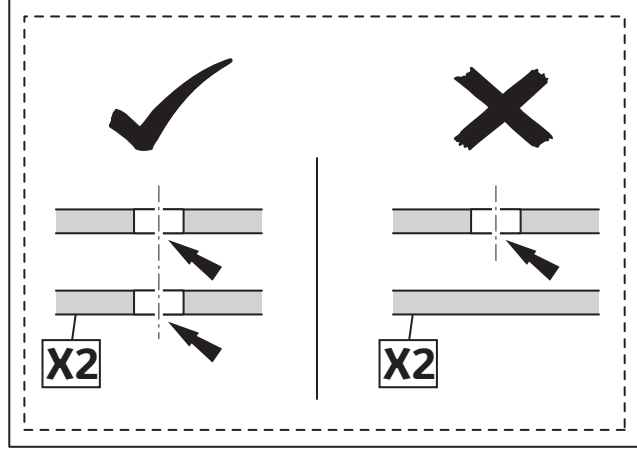
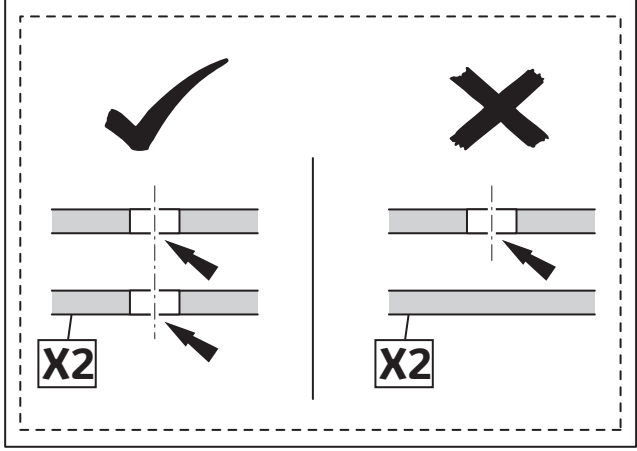
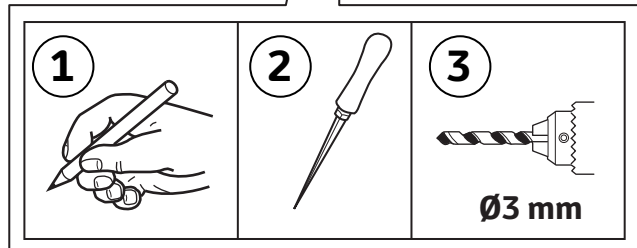
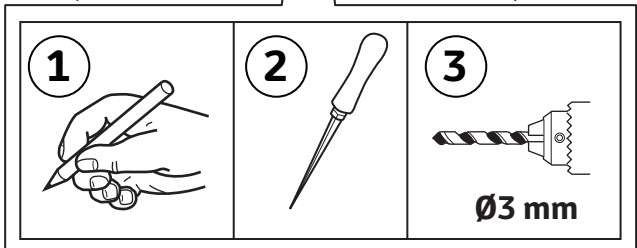
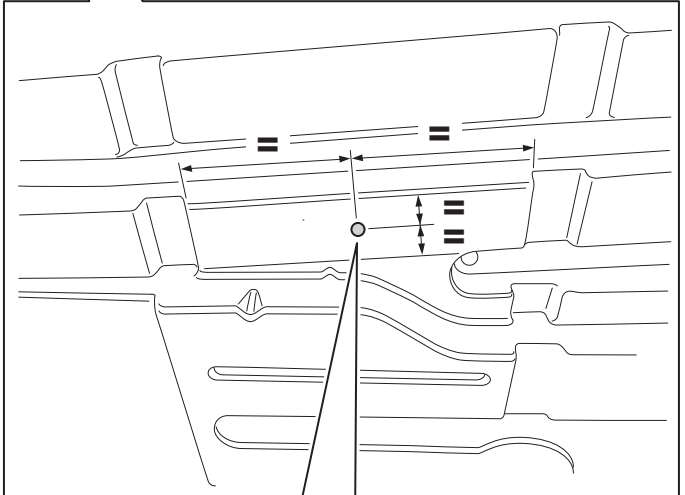
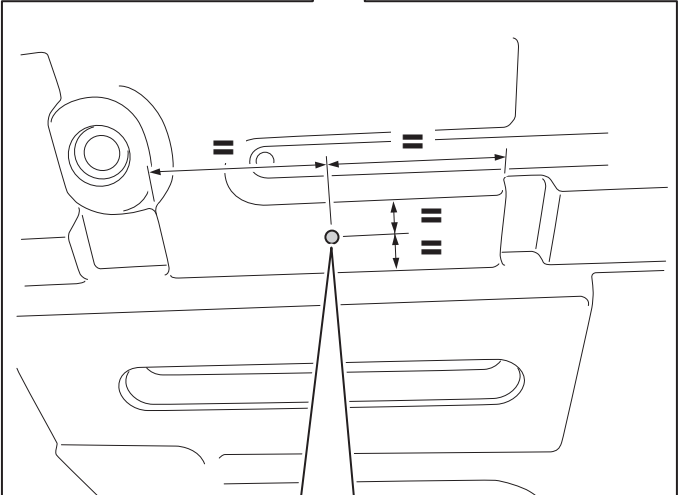
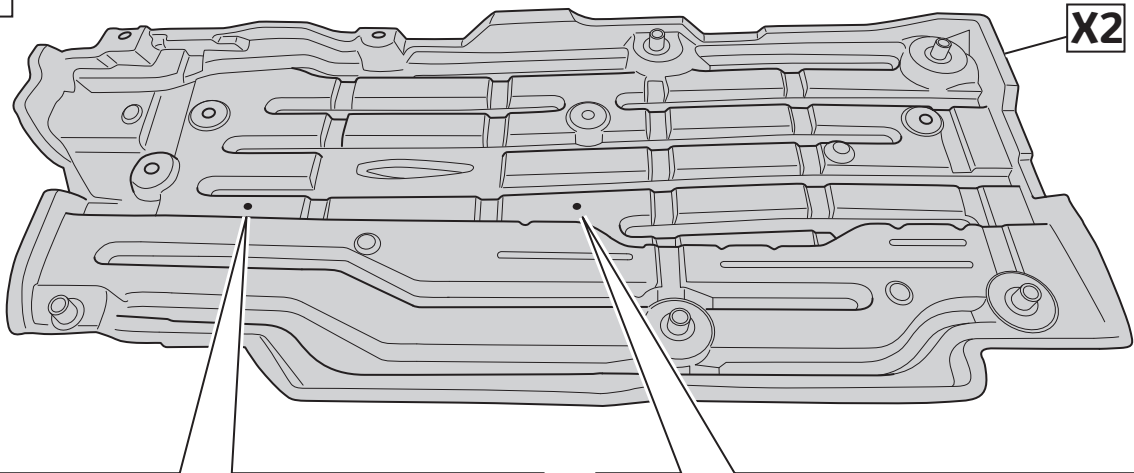

RHD

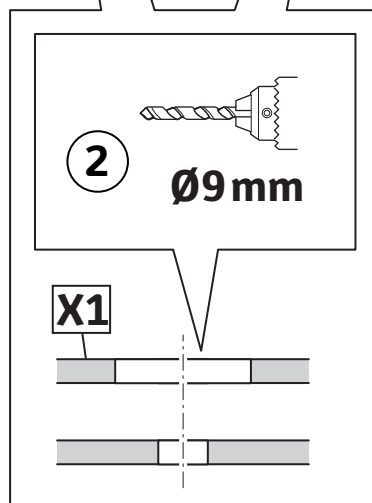
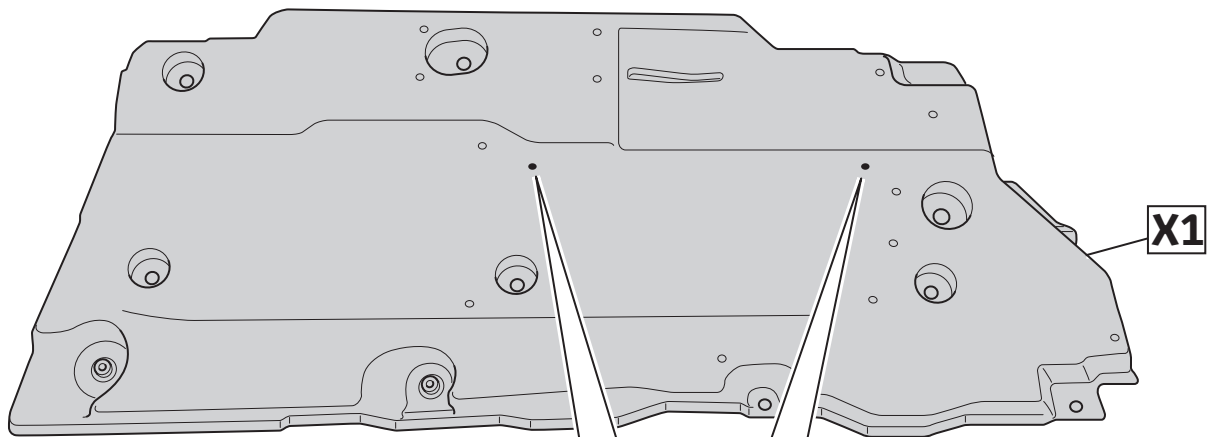
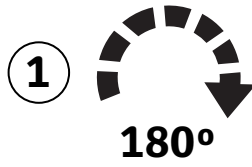
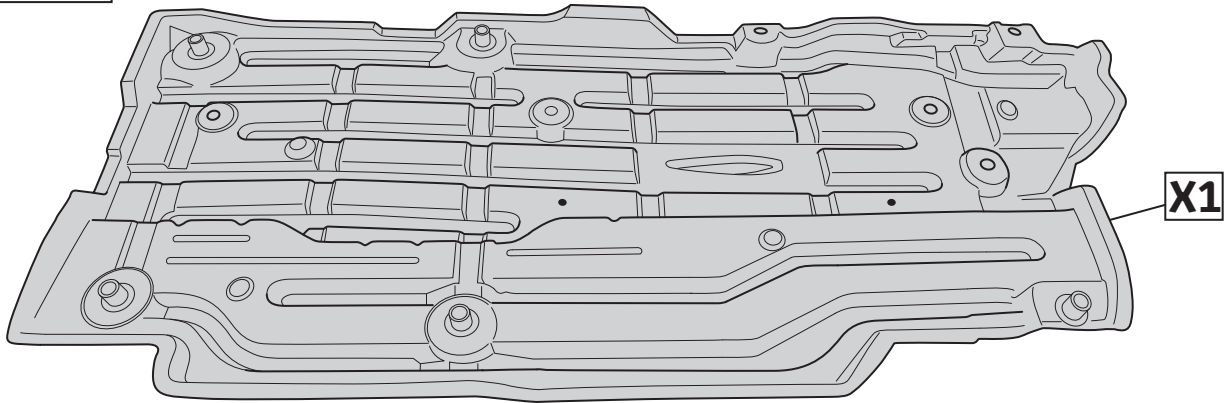

LHD

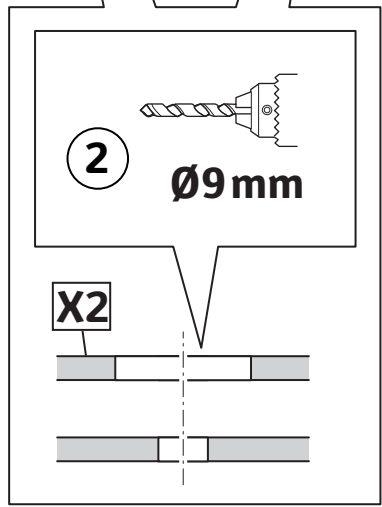
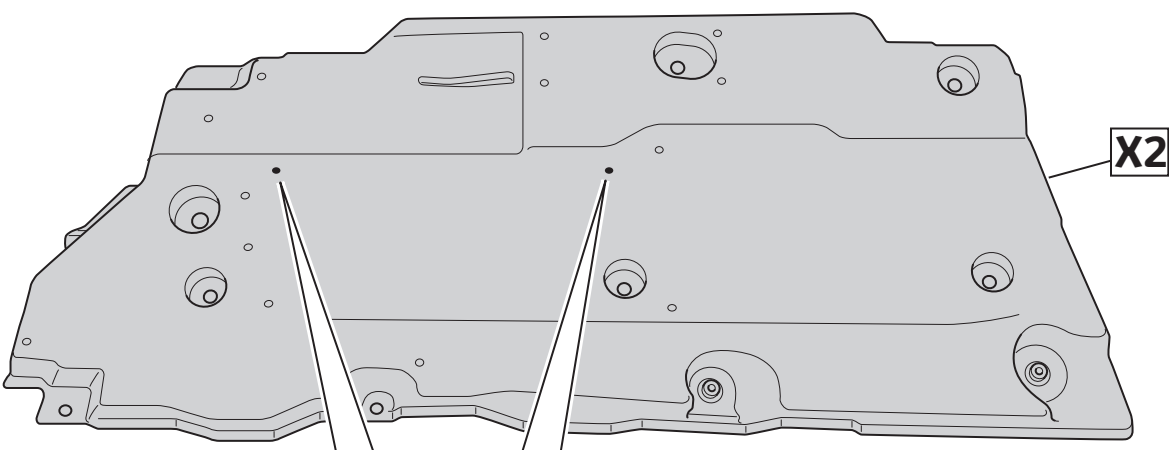
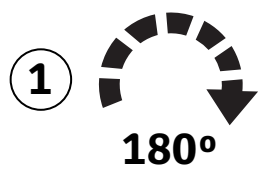
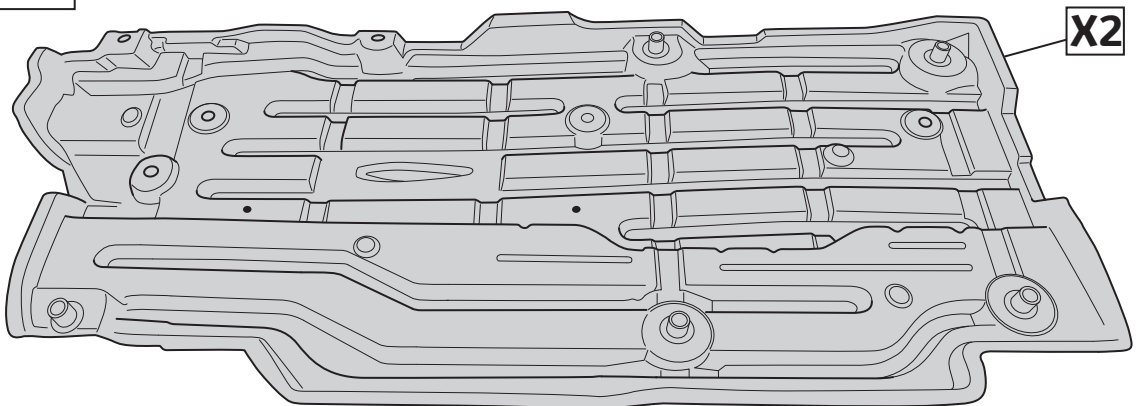

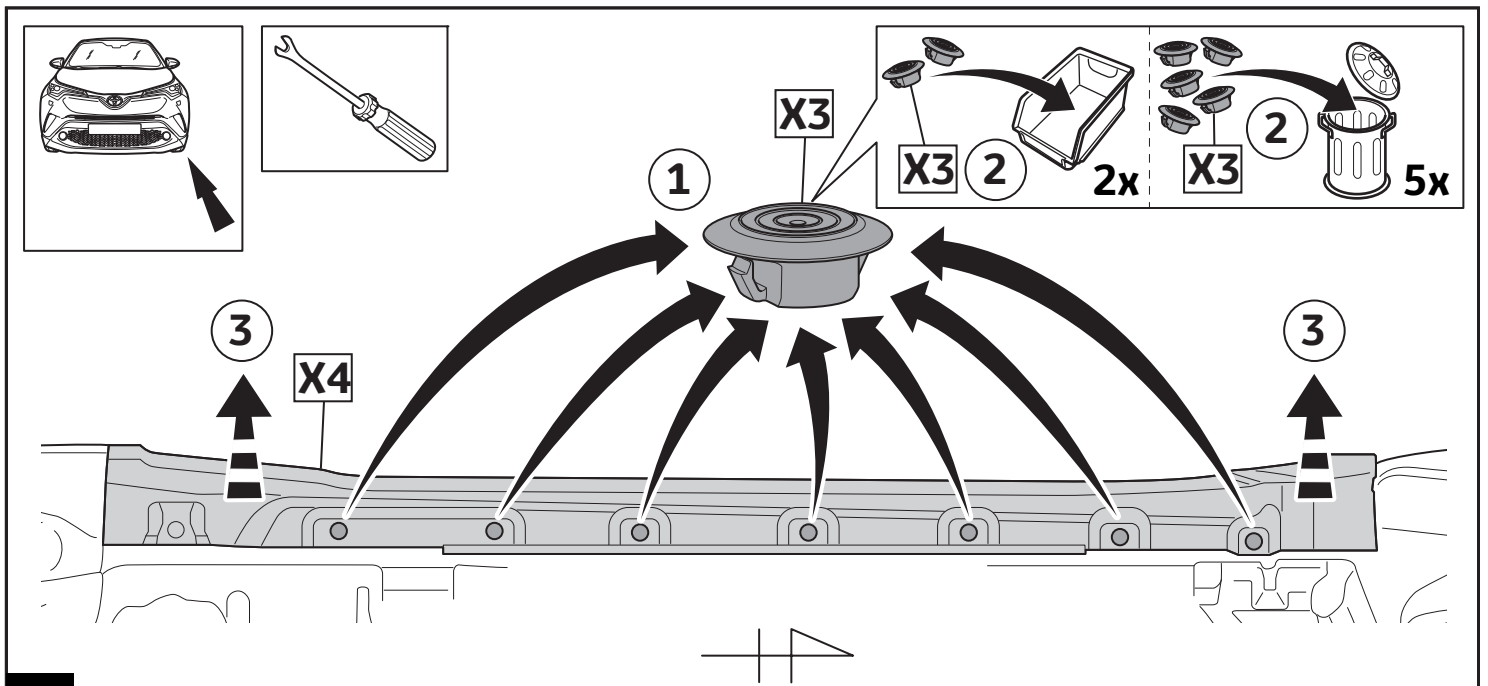

12

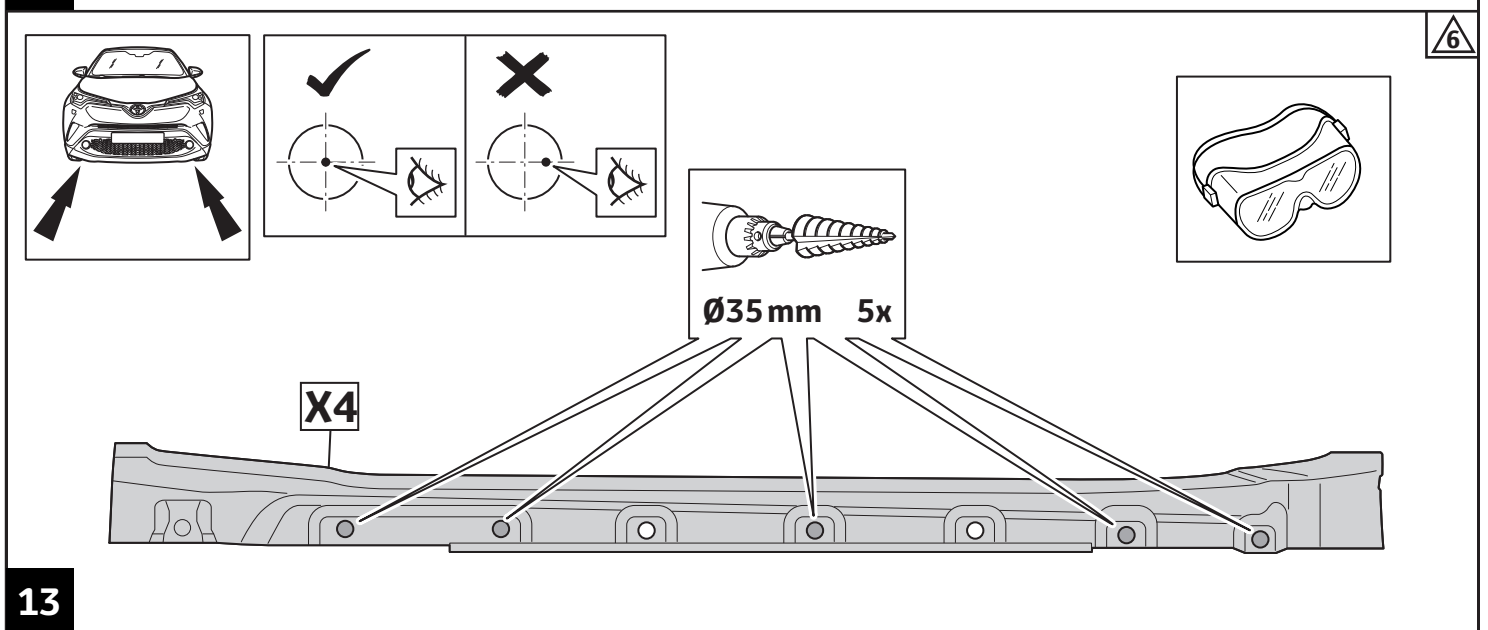

13

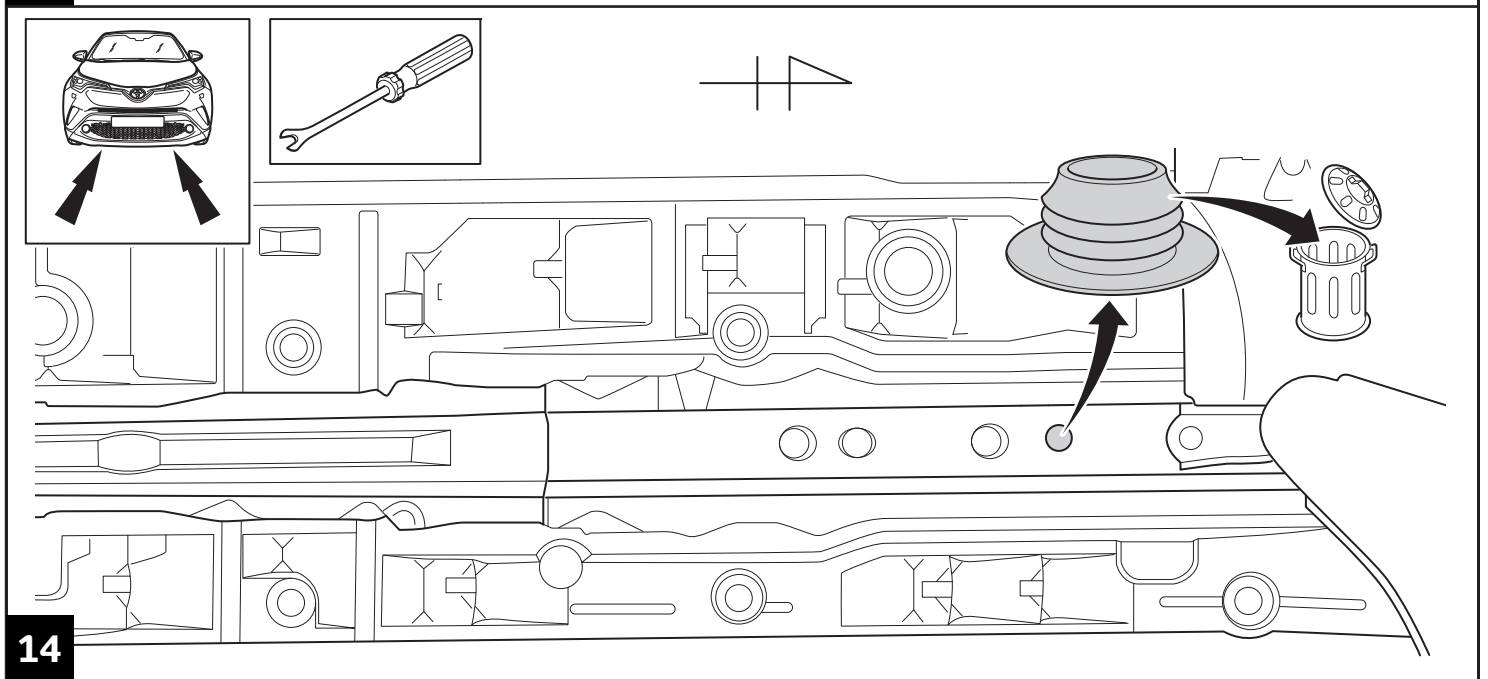

14

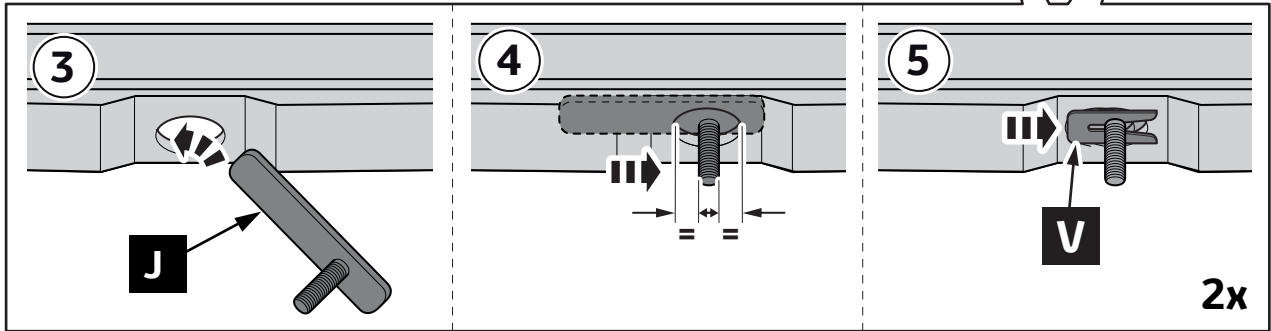
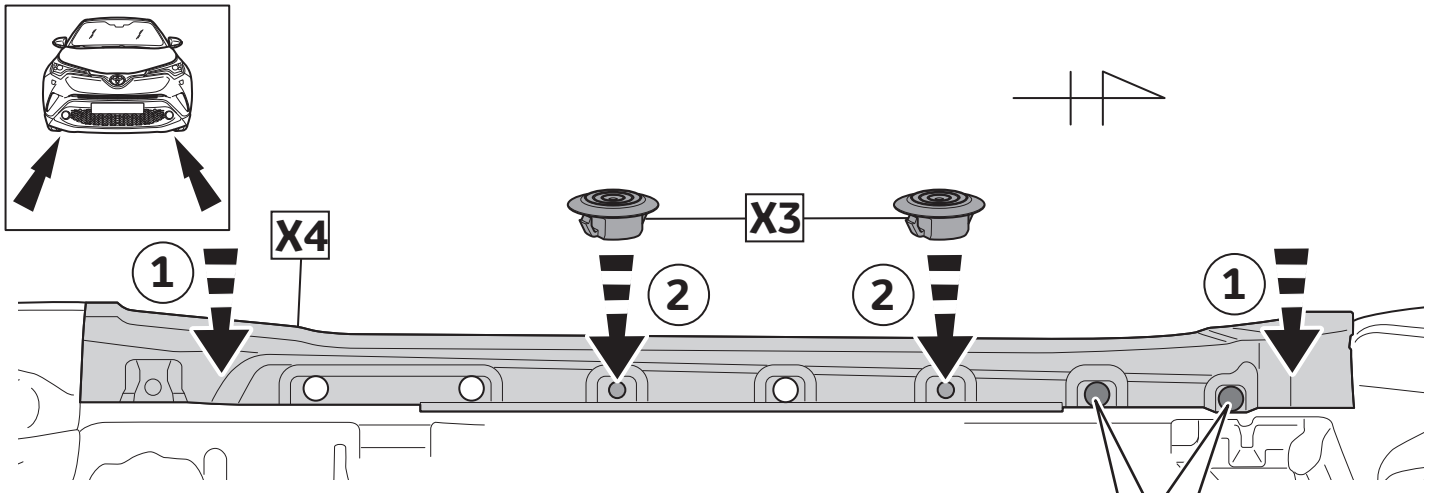

15

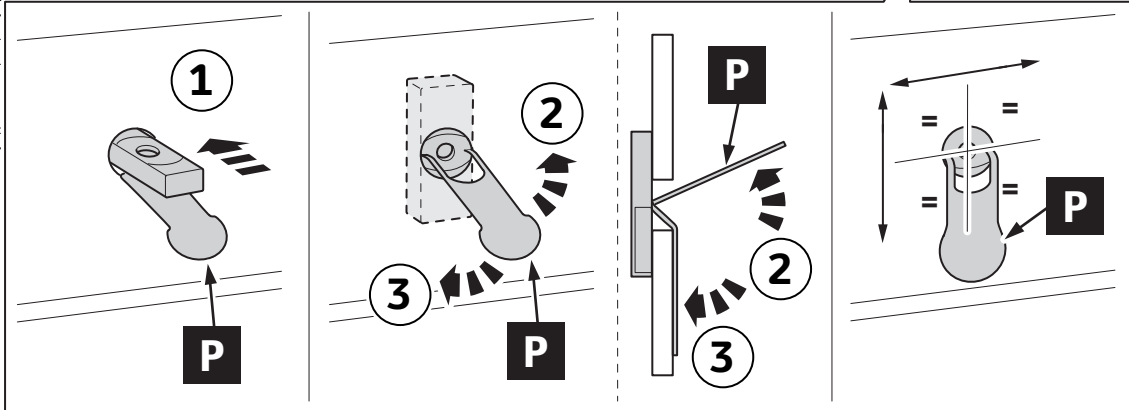
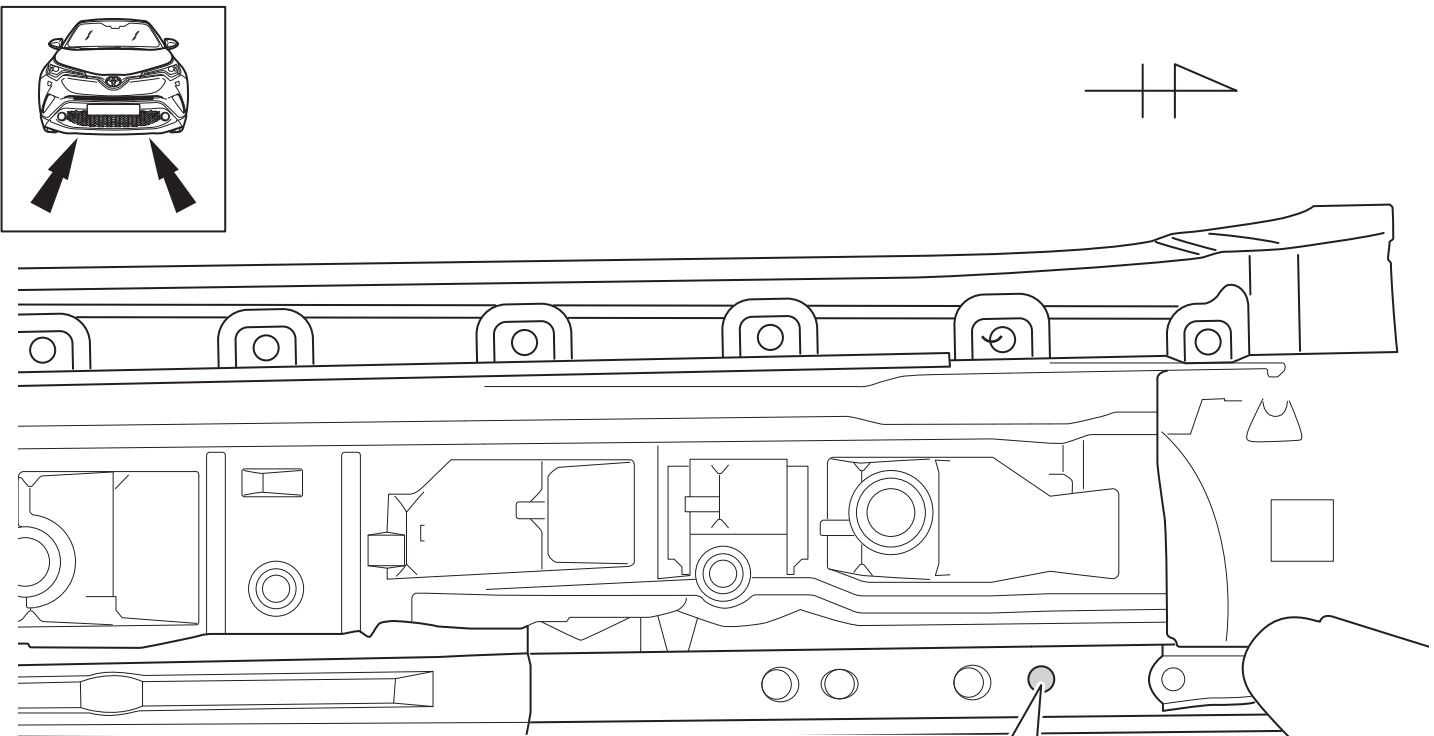

16

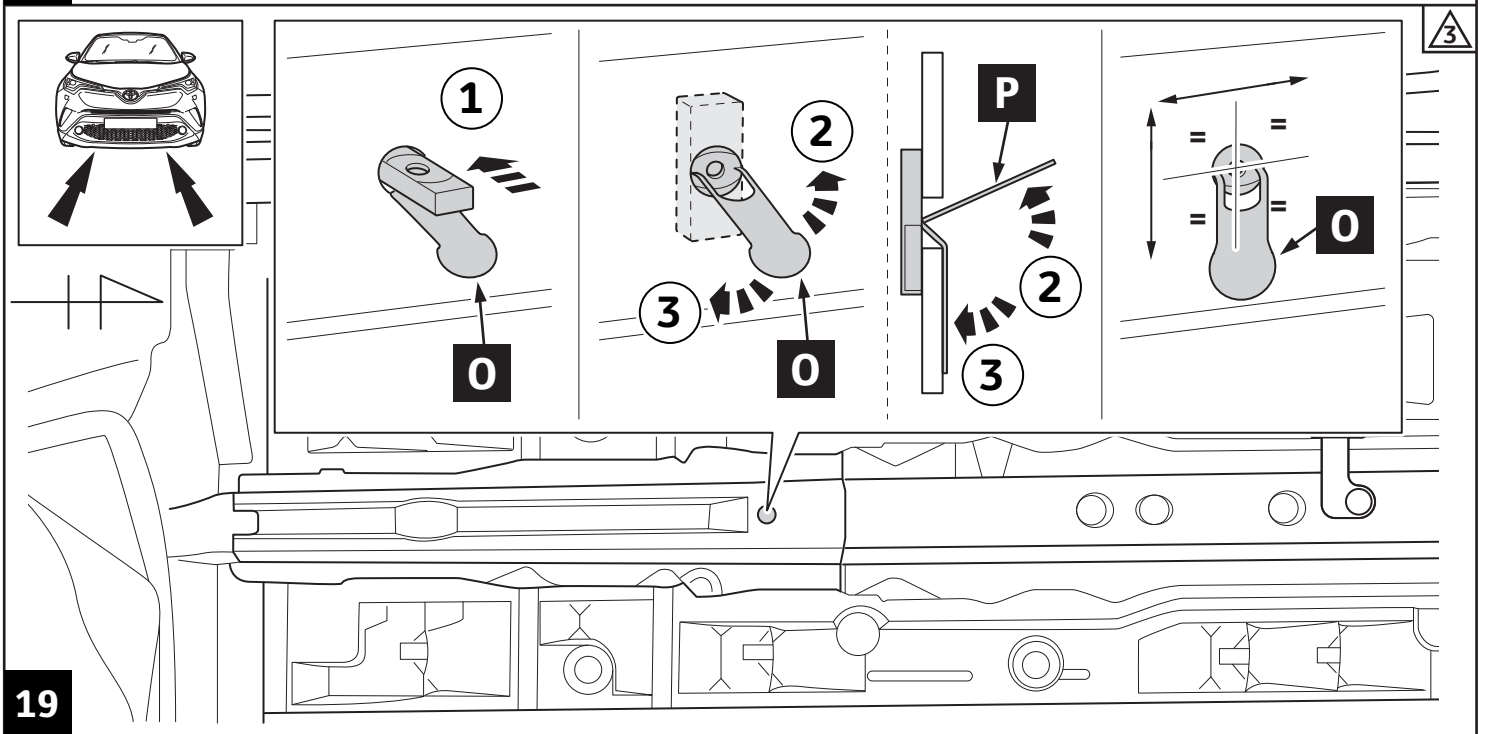
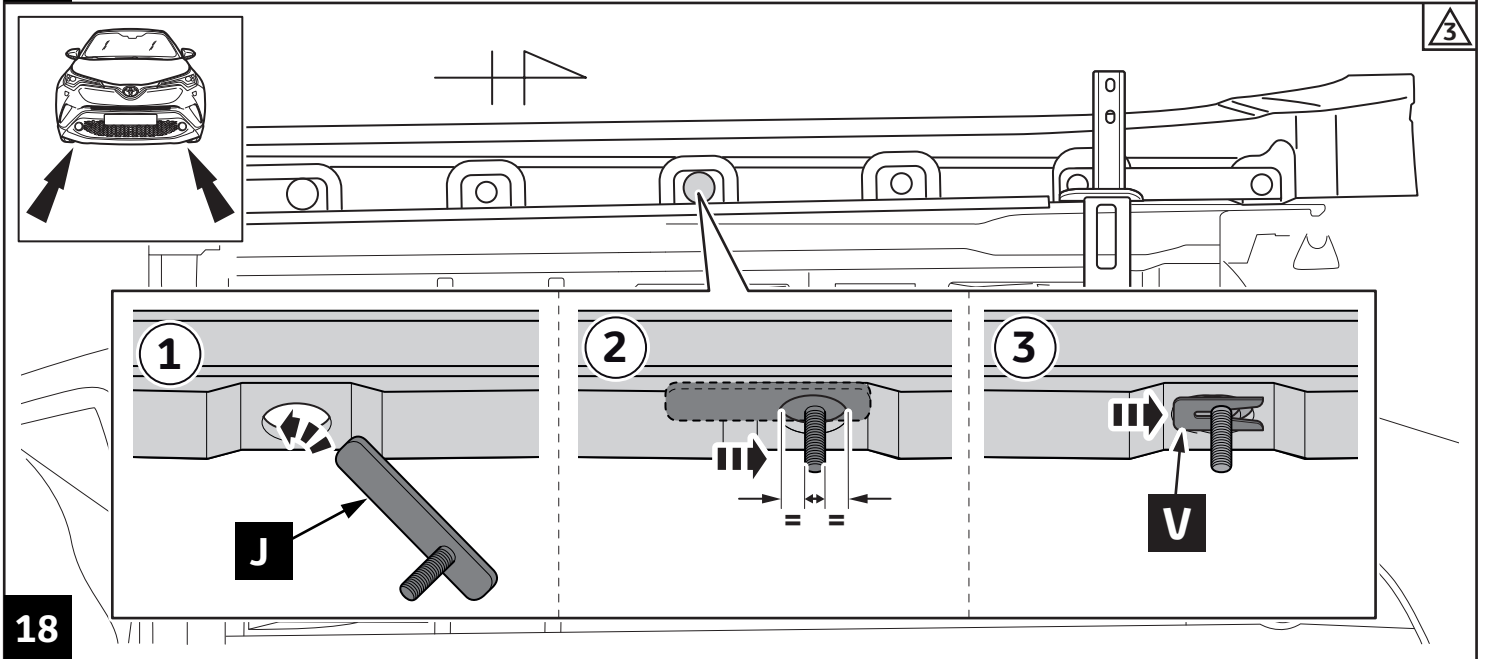
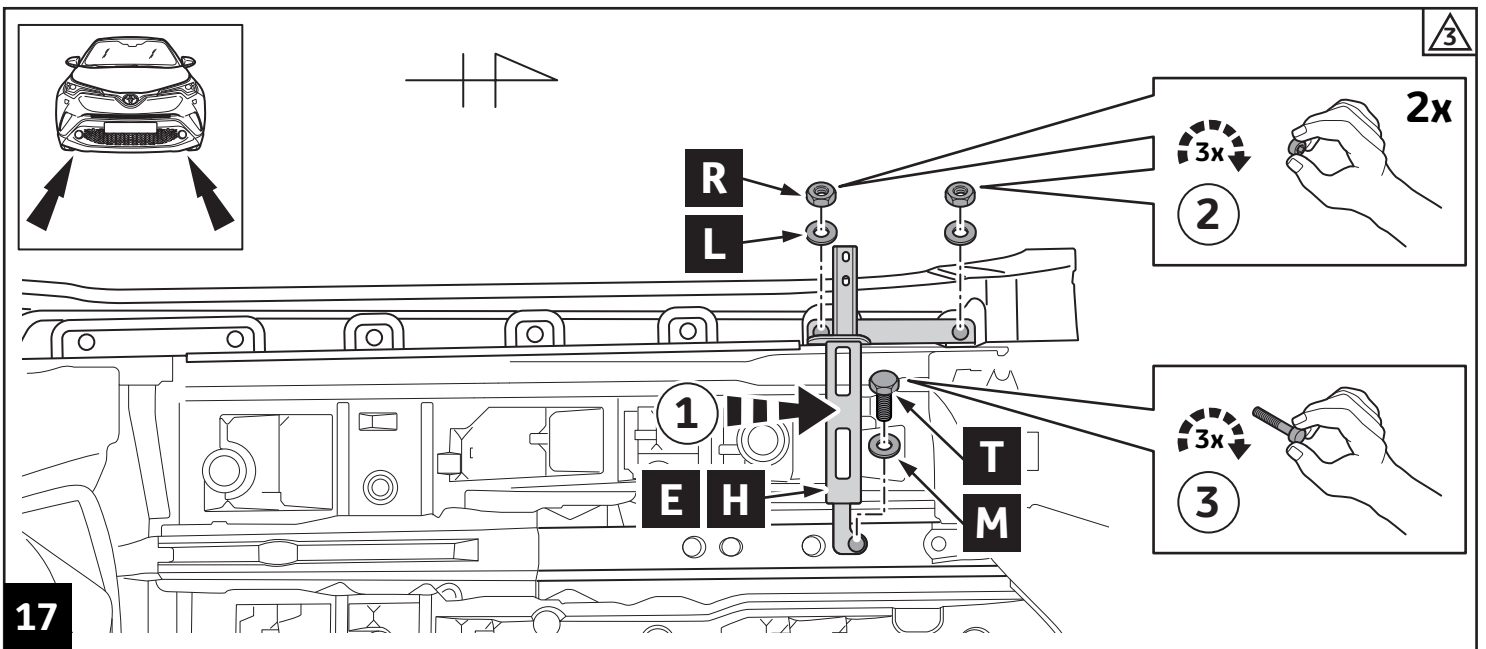

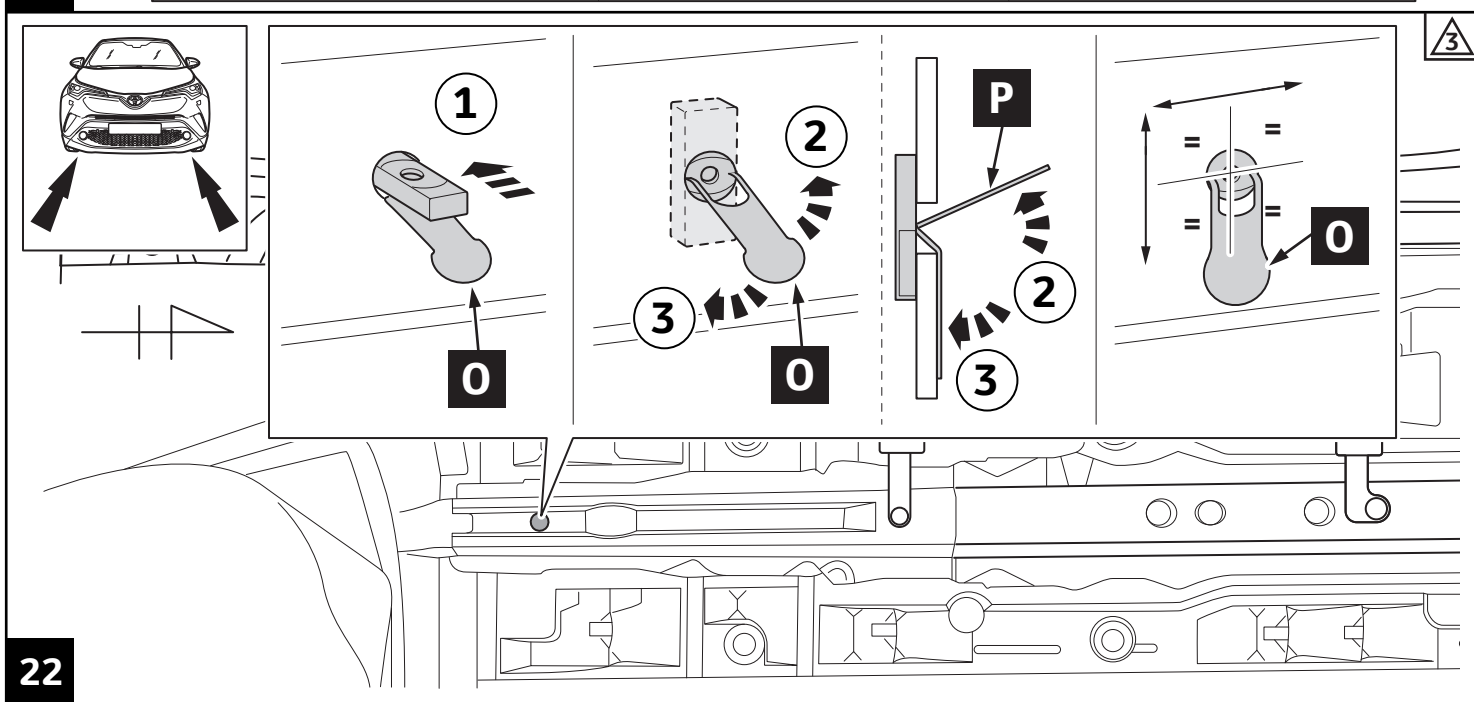
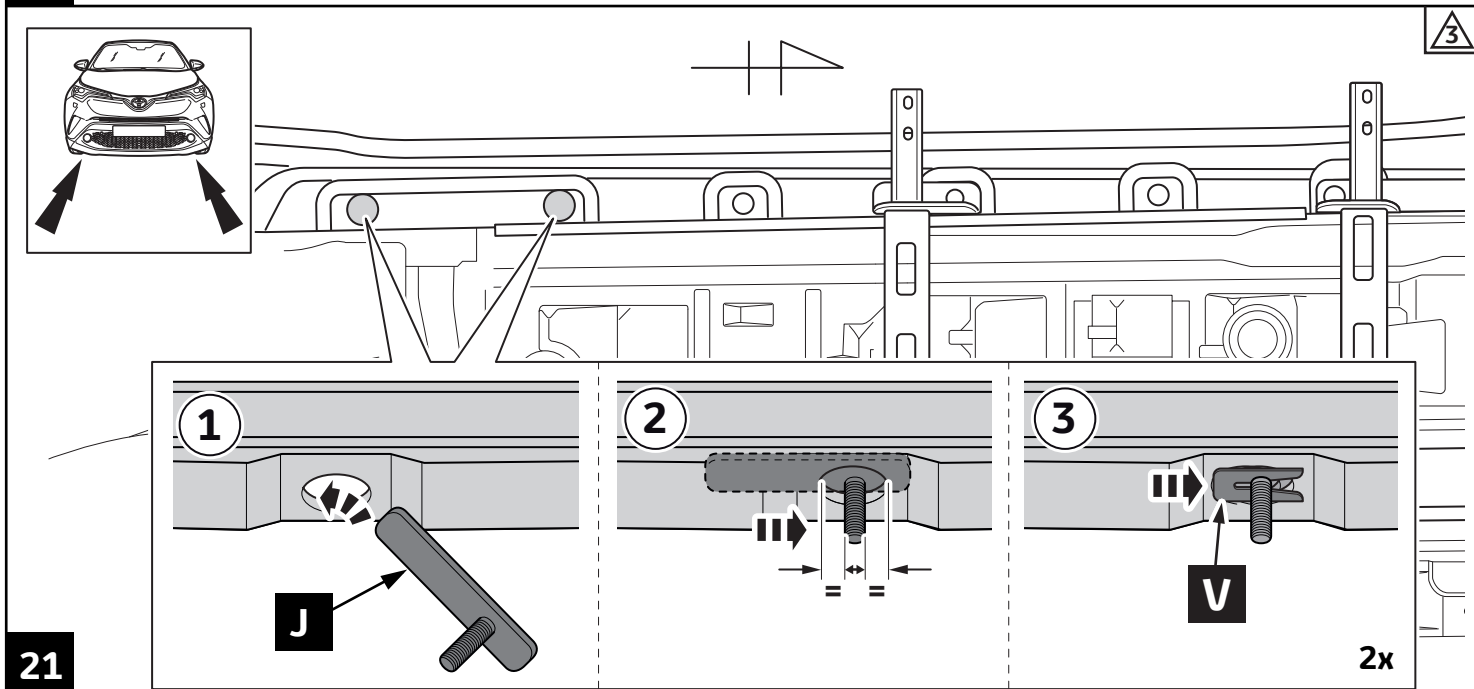
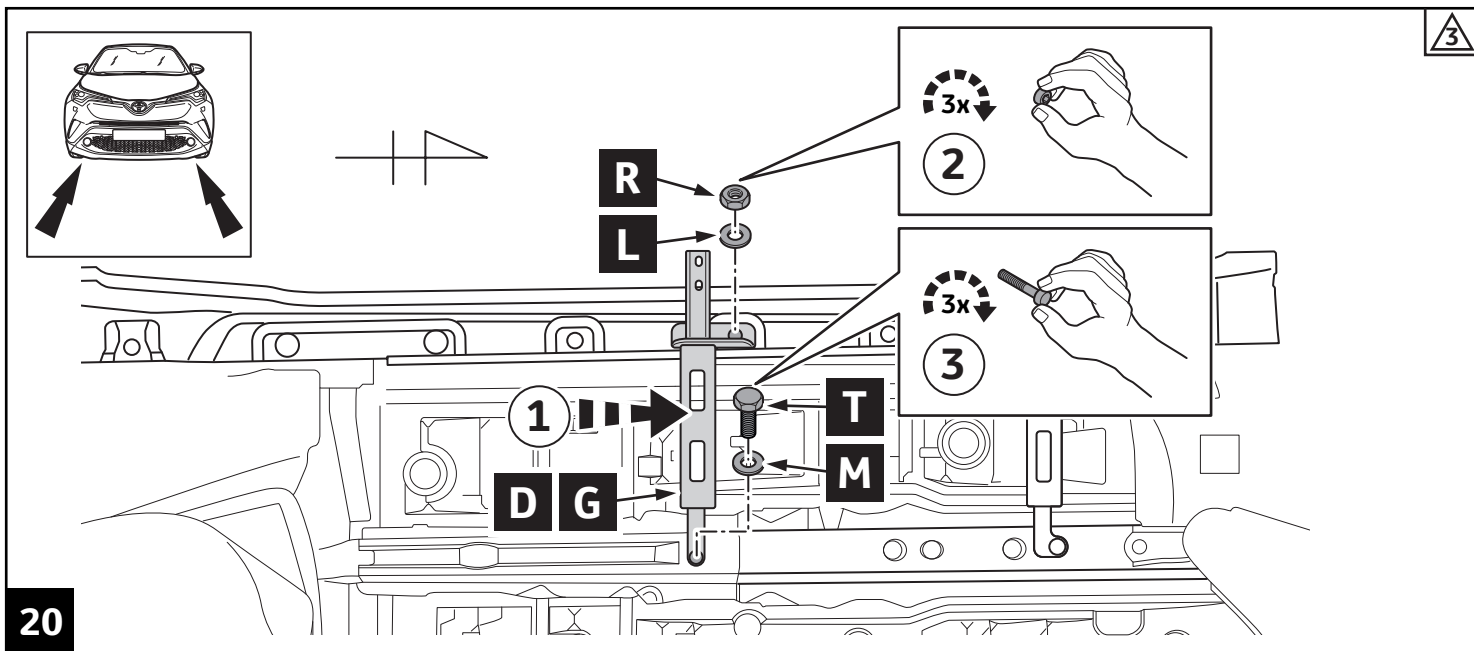

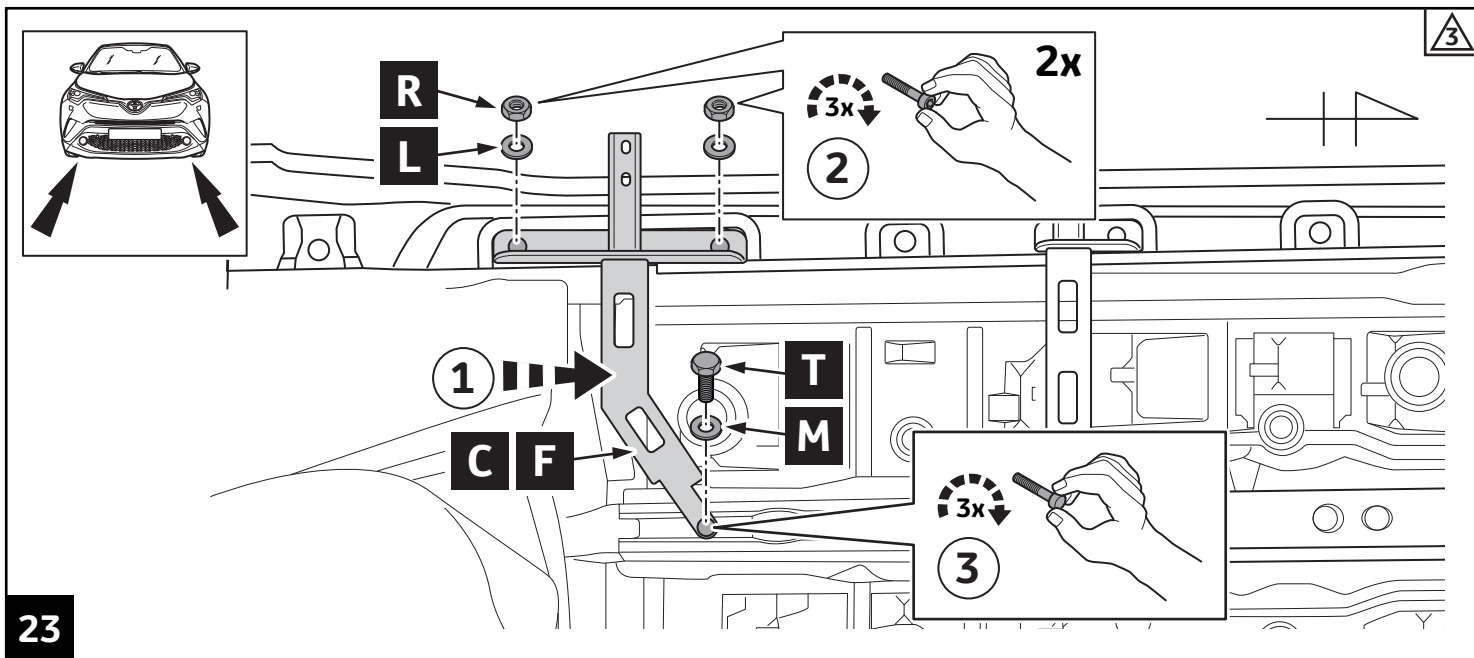

23

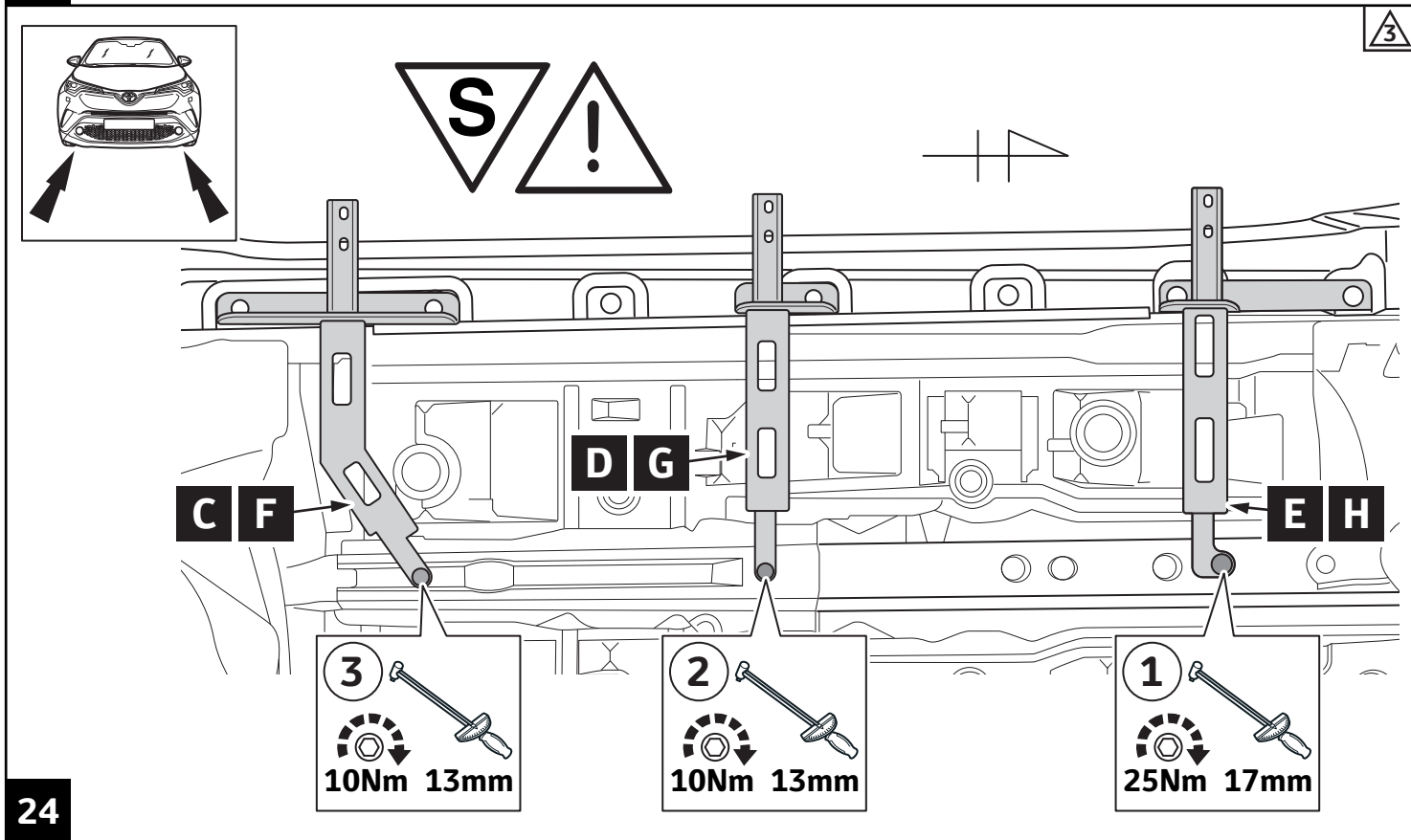

24

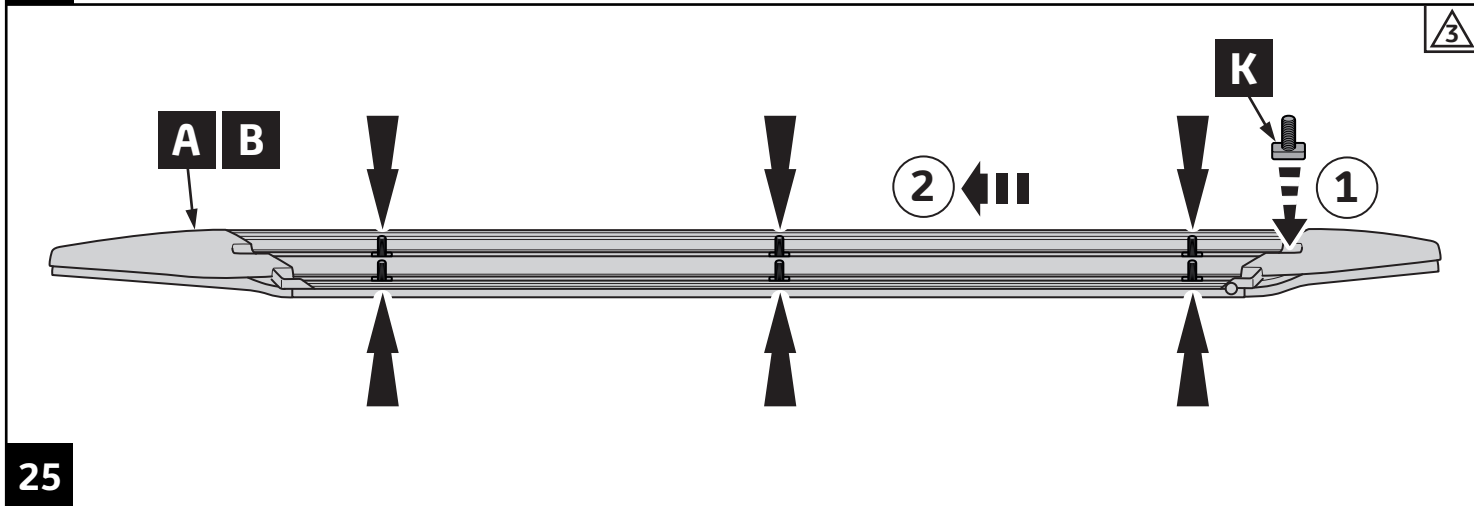

25

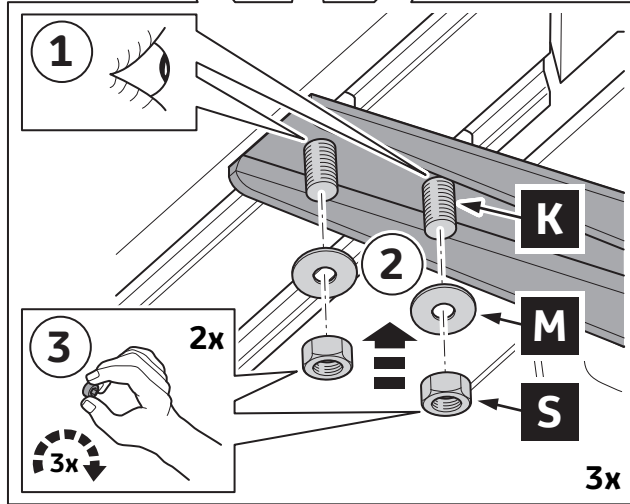
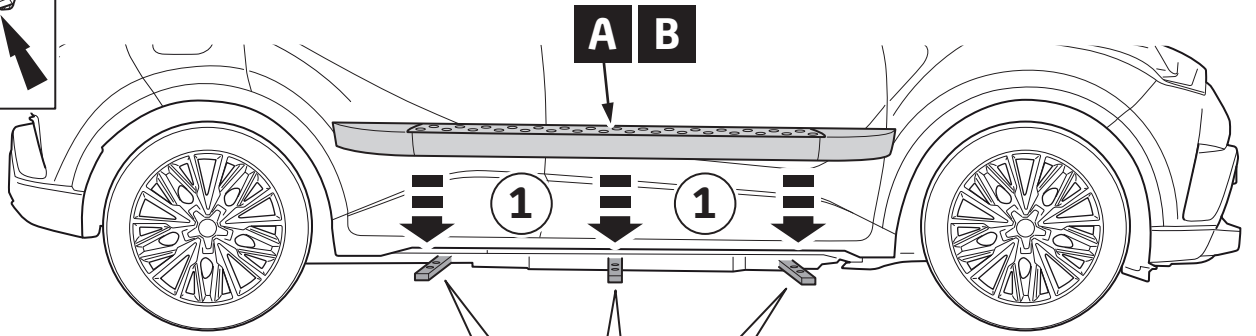
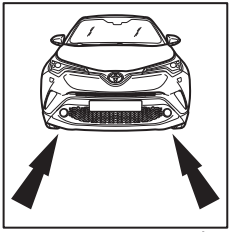

26

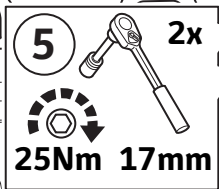
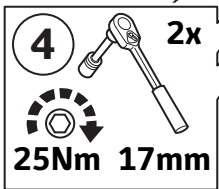
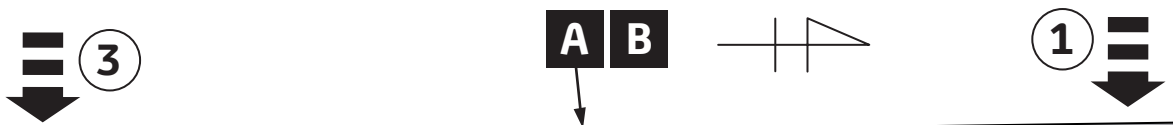
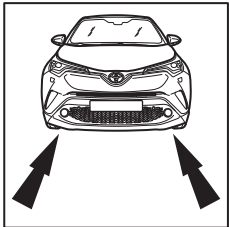

27

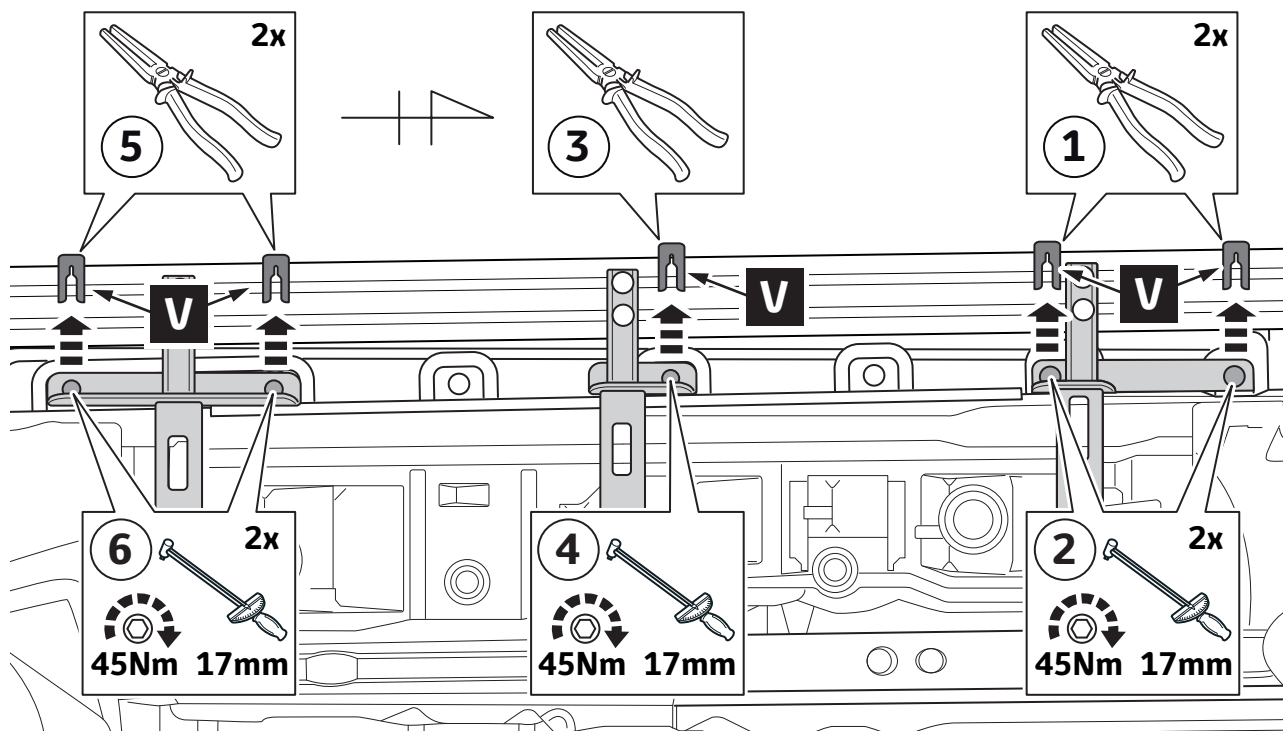
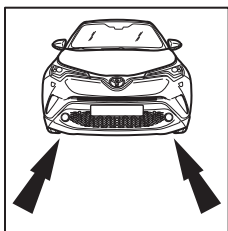

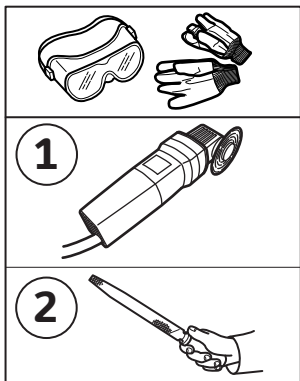

RHD

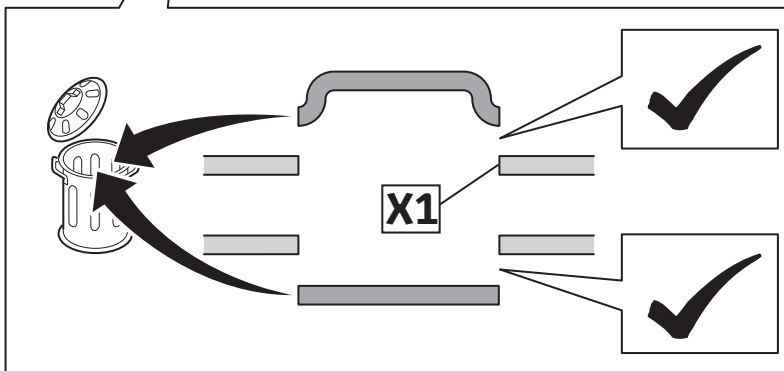
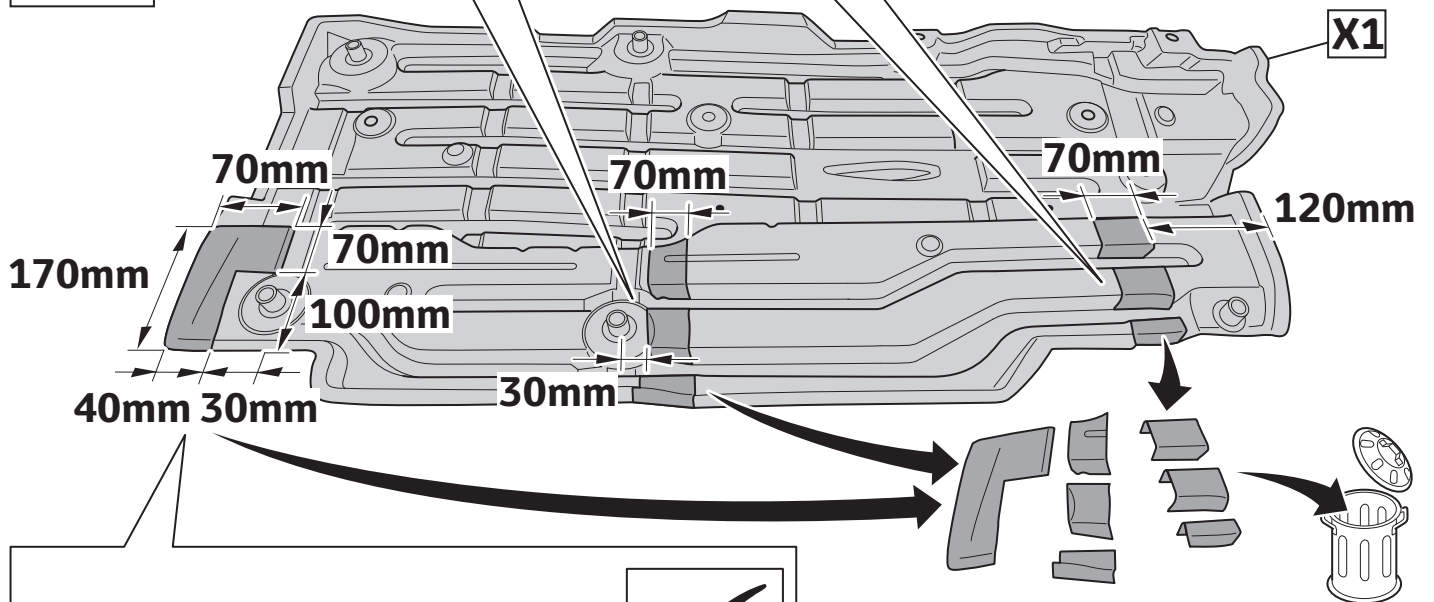
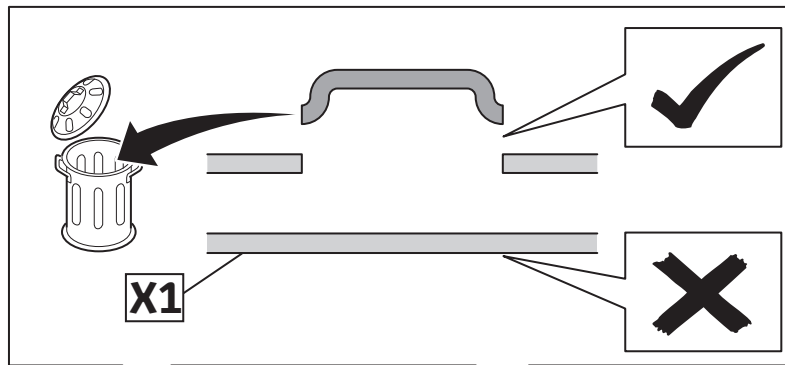

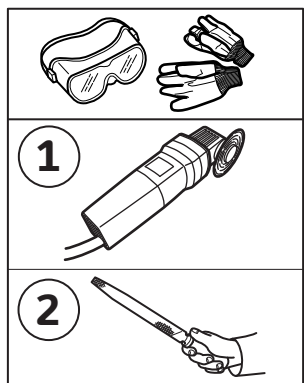

LHD

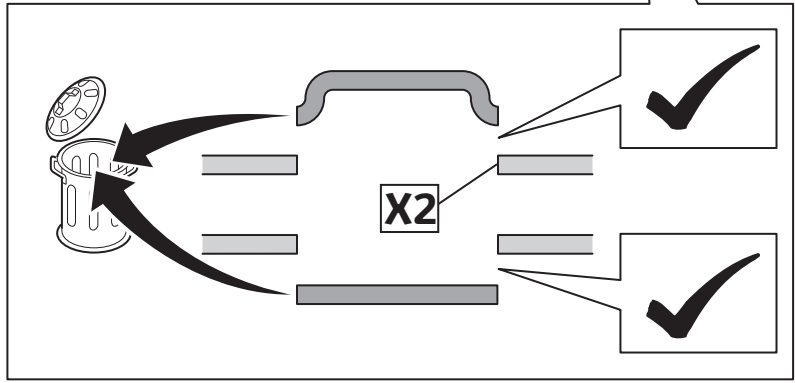
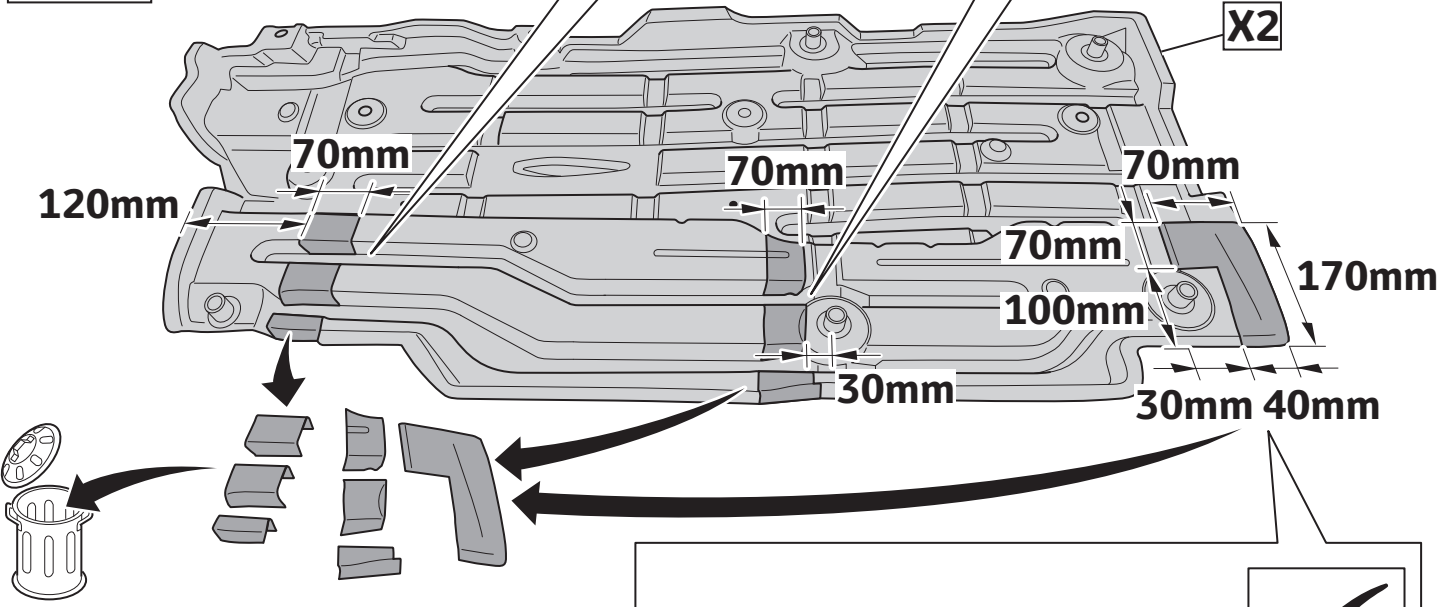
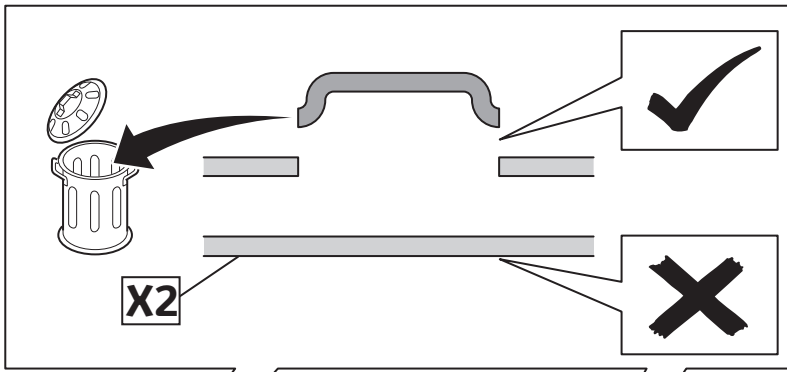

CHECK SHEET Page 1 of 2



TOYOTA

ALWAYS A BETTER WAY

Model / Year Toyota C-HR
As from 2016/10

Side steps

VIN n°

1

P/N = OK

=A **=B**

2

Serial Number **25 Nm** **A** **B** **6x**

LHS

3

Serial Number **45 Nm** **A** **B** **5x**

Serial Number **10 Nm** **A** **B** **2x**

Serial Number **25 Nm** **A** **B** **1x**

LHS

CHECK SHEET Page 2 of 2



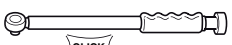

Serial Number
[]



25 Nm

A []

B []

6x

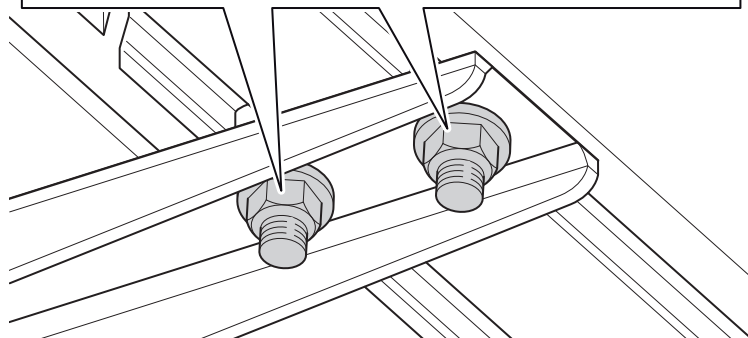

4
RHS



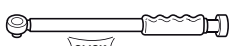

Serial Number
[]

45 Nm

A []

B []

5x

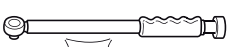

Serial Number
[]

10 Nm

A []

B []

2x



Serial Number
[]

25 Nm

A []

B []

1x

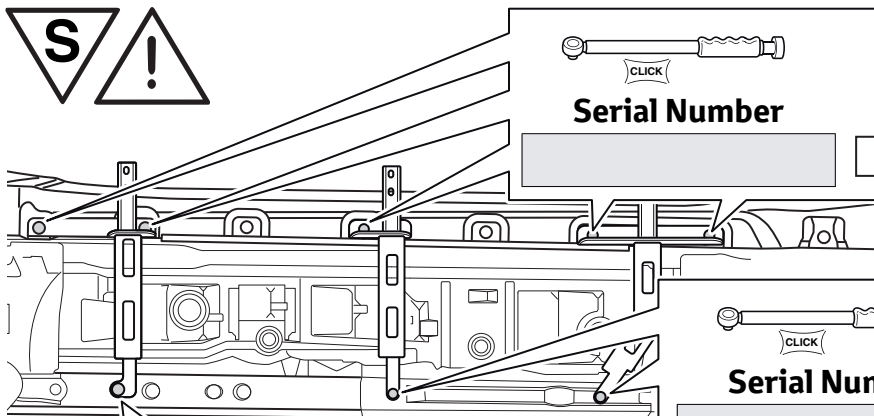

5
RHS

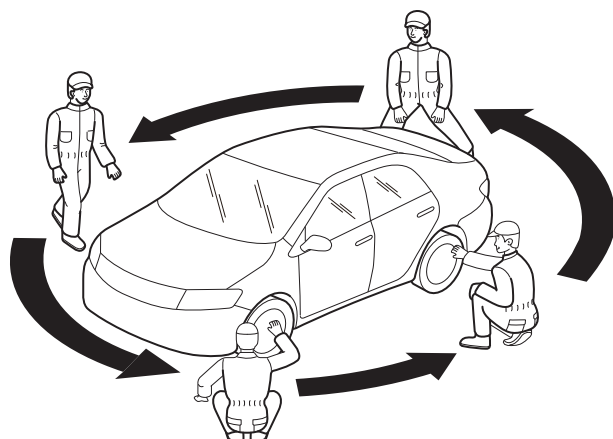

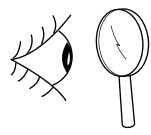
= OK

6

Installation Date:
 . . / . . /

Technician Name & Signature:
 []

Stamp:
 []