



TOYOTA

ALWAYS A
BETTER WAY

Corolla (TS)

Towing hitch vertical detachable

Installation Instructions

Model year: 2019/02

Vehicle code: **E*1**-DW***W

Part number: PW960-02007
82711-34450 Fitting part (Qty. 1)

Manual reference number: AIM 004 334-2

<p>GB FITTING INSTRUCTIONS - TOWBAR</p> <p>Type: 10058570 D-value: 8,6 kN Vertical coupling load towbar: 75 kg Manufacturer: ACPS Automotive Kft. Kadafalva-Heliport, Hrsz.: 1175/1 H-6000 Kecskemét, Hungary</p> <p>Model Application: EC-Type Approval No.: A50-X</p> <p>Expert Fitment Required Ensure that this fitting instructions is passed to the customer</p> <p>In order to use the trailer hitch, simultaneous installation of an electrical kit is required. (Cable set not included)</p> <p>Remove undersealing, anti-corrosion wax and noise-deadening material in the area of the contact surfaces.</p> <p>Apply corrosion protection material as specified in the TOYOTA service guidelines, where necessary.</p> <p>After approximately 1000 km of trailer use, retighten all bolts to the correct torque values.</p> <p>For correct trailer loads please refer to vehicle documents of the individual vehicle model.</p> <p>The coupling ball must be kept clean and well greased*.</p> <p>*EXCEPTION: When stabilizers are used, proceed according to the instructions of the manufacturers of the stabilizer. In this case coupling ball must be inspected for wear at regular intervals.</p> <p>The trailer coupling must be installed and inspected in accordance with the applicable national regulations.</p>	<p>D ANBAUANWEISUNG FÜR ANHÄNGEVORRICHTUNG</p> <p>Type: 10058570 D-Wert: 8,6 kN Stützlast Anhängervorrichtung: 75 kg Hersteller: ACPS Automotive Kft. Kadafalva-Heliport, Hrsz.: 1175/1 H-6000 Kecskemét, Hungary</p> <p>Verwendungsbereich: EWG-Typgenehmigung Nr.: 55R-011848 A50-X</p> <p>Diese Einbauanweisung ist dem Kunden auszuhandigen.</p> <p>Zum Betreiben der Anhängervorrichtung ist der gleichzeitige Einbau eines Elektrobausatzes erforderlich. (Kabelset nicht mitgeliefert)</p> <p>Im Bereich der Anlageflächen muß Unterbodenschutz, Hohlräumkonservierung (Wachs) und Antiröhmaterial entfernt werden.</p> <p>Wo erforderlich, Korrosionsschutz entsprechend den TOYOTA-Service Richtlinien vornehmen.</p> <p>Nach 1000 km Anhängerbetrieb alle Befestigungsschrauben mit vorgeschriebenem Drehmoment nachziehen.</p> <p>Die für das jeweilige Fahrzeugmodell verbindlichen Anhängelasten sind den Fahrzeugpapieren zu entnehmen.</p> <p>Die Kupplungskugel ist sauber zu halten und zu fetten*.</p> <p>*AUSNAHME: Bei Verwendung von Stabilisierungseinrichtungen nach den Anweisungen des Herstellers der Stabilisierungseinrichtung vorgehen. Ebenfalls muß bei Verwendung einer solchen Stabilisierungseinrichtung die Kupplungskugel in regelmäßigen Abständen auf Verschleiß untersucht werden.</p> <p>Der Anbau hat nach dieser Anbauanweisung zu erfolgen und ist gem. §§ 19, 20 oder 21 StVZO durch einen amtlich anerkannten Prüfer oder Sachverständigen zu überprüfen.</p> <p>Die Typgenehmigung der Anhängervorrichtung und diese Anbauanweisung sind dabei vorzulegen. Anbau, Überprüfung und Genehmigung der Anhängervorrichtung müssen den gültigen gesetzlichen Bestimmungen entsprechend durchgeführt werden.</p>	<p>D Der grundsätzliche Anbau der Anhängervorrichtung nach Anhang I, Nr. 5.10 in Verbindung mit Anhang VII der Richtlinie 94/20/EG ist überprüft:</p> <p>* Die vom Fahrzeughersteller serienmäßig genigten Befestigungspunkte sind eingehalten. * Die Vorgaben zum Freiraum um die Kugel beziehungsweise über der Kugel sowie zur erforderlichen Höhe der Kugel über der Fahrbahn (Anhang VII, Abbildung 30 der Richtlinie 94/20/EG) sind beim serienmäßigen Fahrzeug gewährleistet. * Die Kenndaten D-Wert und zul. statische Stützlast der Anhängervorrichtung sowie das amtliche Prüfzeichen befinden sich auf dem Typschild. * Nur im Anhängerbetrieb darf das rückwärtige amtliche Kennzeichen durch die Kugel verdeckt werden, ansonsten ist sie abzunehmen und im Kofferraum befestigt mitzuführen. Diese Montage- und Betriebsanleitung ist im Fahrzeug mitzuführen und ggf. berechtigten Personen vorzulegen.</p> <p>Der Eintrag dieser EG-geprüften Anhängervorrichtung in die Fahrzeug-Papiere ist nicht (mehr) erforderlich; allerdings wird insbesondere bei Selbstmontage empfohlen, das Fahrzeug nach dem ordnungsgemäßen Anbau der Anhängervorrichtung bei einer auf den Anbau von ACPS Anhängervorrichtungen geschulten Fachwerkstätte vorzuführen, damit die Einhaltung aller Bedingungen nochmals überprüft wird.</p> <p>Montagehinweise: Die Anhängervorrichtung ist ein Sicherheitsteil. Deshalb darf sie nur sach- und fachgerecht montiert werden.</p> <p>Jegliche Änderungen bzw. Umbauten an der Anhängervorrichtung sind verboten. Sie führen zum Erlöschen der Genehmigung. Isoliermasse bzw. Unterbodenschutz am Fahrzeug -falls vorhanden- im Bereich der Anlageflächen der Anhängervorrichtung sind zu entfernen. Blanke Karosserieteile sowie Bohrungen mit Rostschutz versiegeln.</p> <p>Falls erforderlich, Korrosionsschutz entsprechend den Toyota-Service-Richtlinien vornehmen.</p> <p>Betriebshinweise: Sämtliche Befestigungsschrauben der Anhänger-</p>	<p>D vorrichtung sind nach circa 1000 Anhänger - km mit den vorgeschriebenen Anzugsdrehmomenten nachziehen.</p> <p>Die Kupplungskugel ist sauber zu halten und leicht zu fetten. Die Verwendung einer Schutzkappe wird empfohlen. Werden jedoch Stabilisierungseinrichtungen verwendet, muß die Kupplungskugel fettfrei sein. Die Hinweise in den diesbezüglichen Betriebsanleitungen sind zu beachten.</p> <p>Sobald an einer beliebigen Stelle ein Kupplungskugel-Durchmesser von 49,0 mm oder kleiner erreicht ist, darf die Kugel der Anhängervorrichtung aus Sicherheitsgründen nicht mehr weiter benutzt werden.</p> <p>Das Leergewicht des Fahrzeuges erhöht sich nach Montage der Anhängervorrichtung um circa 20 kg.</p> <p>Die zulässige Anhängelast und statische Stützlast für das Fahrzeug sind zu beachten. Diese Angaben sind in der Bedienungsanleitung des Fahrzeuges und in den Fahrzeug-Papieren vermerkt. Kontrolle: Die auf dem Fabrik Schild der Anhängervorrichtung aufgeführten Daten müssen gleich oder größer sein als die vom Fahrzeughersteller genehmigten Daten. Falls sie größer sind, bleiben die vom Fahrzeughersteller genehmigten Daten gültig.</p>
<p>E INSTRUCCIONES DE MONTAJE PARA EL DISPOSITIVO DE REMOLQUE</p> <p>Tipo: 10058570 Valor-D: 8,6 kN Carga de apoyo de remolque: 75 kg Fabricante: ACPS Automotive Kft. Kadafalva-Heliport, Hrsz.: 1175/1 H-6000 Kecskemét, Hungary</p> <p>Campo de aplicación: la CEE nº: A50-X</p> <p>El montaje deberá ser realizado por un taller especializado</p> <p>Estas instrucciones de montaje deben ser entregadas al cliente.</p> <p>Para el funcionamiento del dispositivo de remolque hace falta al mismo tiempo el montaje de un conjunto eléctrico. (Juego de cables no viene incluido)</p> <p>En el área de las superficies de apoyo han de eliminarse la protección del fondo, la conservación del espacio hueco (cera) y el material antiresonante.</p> <p>En caso de necesidad, efectuar la protección anticorrosiva de acuerdo con las directrices de servicio de TOYOTA.</p> <p>Al cabo de 1.000 km, de funcionamiento de remolque, reapretar todos los tornillos de fijación con el par de fuerzas especificado.</p> <p>Las cargas de remolque admisibles para cada modelo respectivo de vehículo se pueden ver en la documentación del mismo.</p> <p>La bola de acoplamiento ha de mantenerse limpia y engrasarse*.</p> <p>* EXCEPCIÓN: En caso de utilización de dispositivos de estabilización, deberá procederse de acuerdo con las instrucciones del fabricante del dispositivo de estabilización. Igualmente, al utilizar tal dispositivo de estabilización, la bola de acoplamiento ha de examinarse a intervalos regulares en cuanto a su desgaste.</p> <p>El montaje, la comprobación y la autorización del dispositivo de remolque deberán efectuarse de acuerdo con las disposiciones legales válidas.</p>	<p>F NOTICE DE MONTAGE DE L'ATTELAGE</p> <p>Type: 10058570 Valeur D: 8,6 kN Charge d'appui de l'attelage: Fabricant: ACPS Automotive Kft. Kadafalva-Heliport, Hrsz.: 1175/1 H-6000 Kecskemét, Hungary</p> <p>Domaine d'utilisation: N° d'homologation de la CE: A50-X</p> <p>Confier le montage à un atelier spécialisé</p> <p>Cette notice de montage doit être remise au client.</p> <p>L'utilisation du dispositif de remorquage implique le montage simultané d'un set électrique. (Faisceau de câbles non fourni !)</p> <p>La protection du dessous de caisse, la cire de conservation des corps creux et le produit d'insonorisation doivent être enlevés.</p> <p>Procéder à la protection contre la corrosion là où nécessaire et conformément aux directives de TOYOTA-Service.</p> <p>Après avoir tracté une remorque sur 1000 km resserrer toutes les vis de fixation au couple prescrit.</p> <p>Les charges pouvant être tractées par chacun des modèles sont prescrites dans les papiers du véhicule.</p> <p>La rotule doit toujours être propre et graissée*.</p> <p>* EXCEPTION: En cas d'utilisation de dispositifs de stabilisation, procéder selon les instructions du fabricant du dispositif de stabilisation. La rotule doit également être périodiquement vérifiée quant à son usure éventuelle si un tel dispositif de stabilisation est employé.</p> <p>Le dispositif de remorquage doit être monté, vérifié et autorisé conformément aux dispositions légales en vigueur.</p>	<p>I INSTRUZIONE DI MONTAGGIO DEL DISPOSITIVO DI TRAINO</p> <p>Tipo: 10058570 Valore-D: 8,6 kN Carico del timone di traino: Produttore: ACPS Automotive Kft. Kadafalva-Heliport, Hrsz.: 1175/1 H-6000 Kecskemét, Hungary</p> <p>Campo d'uso: EURO approval No.: A50-X</p> <p>Il montaggio dev'essere affidato a un'officina specializzata.</p> <p>Le presenti istruzioni di montaggio devono essere consegnate al cliente.</p> <p>Per l'utilizzazione del dispositivo di traino è necessaria l'applicazione di un relativo impianto elettrico. (Set di cavi non in dotazione)</p> <p>Allontanare la protezione sottoscocca, il trattamento antiruggine dei recessi irraggiungibili (cera) e la massa antirullo nell'ambito delle superfici di contatto.</p> <p>Se è dove necessario applicare la protezione anticorrosione attenendosi alle direttive service TOYOTA.</p> <p>Dopo 1000 km di uso del traino, stringere di nuovo tutte le viti di fissaggio con il momento torcente prescritto.</p> <p>Il peso massimo trainabile vincolante per il rispettivo modello di veicolo trainante è riportato nella rispettiva documentazione tecnica del veicolo.</p> <p>L'aggancio a sfera dev'essere mantenuto pulito e ingrassato (*).</p> <p>(*) ECCEZIONE: Nel caso vengano impiegati dispositivi di stabilizzazione atenersi alle istruzioni del produttore del dispositivo di stabilizzazione. Nel caso d'impiego di un tale dispositivo di stabilizzazione è pure necessario di controllare a regolari intervalli di tempo il grado di usura dell'aggancio a sfera.</p> <p>Il montaggio, la revisione ed il collaudo del dispositivo di traino dovranno essere eseguiti nel rispetto della normativa legale vigente.</p>	<p>P INSTRUÇÕES DE MONTAGEM PARA DISPOSITIVO DE REBOQUE</p> <p>Tipo: 10058570 Valor D: 8,6 kN Capacidade de carga de reboque: 75 kg Fabricante: ACPS Automotive Kft. Kadafalva-Heliport, Hrsz.: 1175/1 H-6000 Kecskemét, Hungary</p> <p>Campo de utilização: N° de autorização CEE: A50-X</p> <p>Mandar efectuar a montagem em uma oficina especializada</p> <p>Estas instruções de montagem deverão ser entregues ao cliente.</p> <p>Para operação deste dispositivo de reboque, é necessário montar um conjunto eléctrico simultaneamente. (O conjunto de cabos não está incluído)</p> <p>Na superfície do sistema deverá ser removida a protecção inferior da carroçaria, conservante de espaços ocos (cera) e material anti-ruído.</p> <p>Efectuar as medidas de protecção anti-corrosiva onde for necessário, de acordo com as directrices de serviço da TOYOTA.</p> <p>Reapertar todos parafusos de fixação com o binário de aperto prescrito após 1000 km.</p> <p>As cargas de reboque permitidas autorizadas para cada modelo de veículo podem ser vistas nos documentos do veículo.</p> <p>A bola de engate de reboque deverá ser mantida limpa e lubrificada*.</p> <p>* EXCEPCÃO: Utilizar dispositivos estabilizadores de acordo com as instruções de operação dos fabricantes dos dispositivos. Da mesma forma deve-se controlar a bola de engate em intervalos regulares quanto à desgastar no caso de se utilizar tais dispositivos estabilizadores.</p> <p>A montagem, controle e autorização do dispositivo de reboque deverão ser executados de acordo com as normas legais.</p>

<p>NL MONTAGE-INSTRUCTIE VOOR TREKHAAK</p> <p>Type: 10058570 D-waarde: 8,6 kN Draaglast trekhaak: 75 kg Fabrikant: ACPs Automotive Kft. Kadafalva-Heliport, Hrsz.: 1175/1 H-6000 Kecskemét, Hungary Toepassingsgebied: Corolla (TS) EEG-typegoedkeuring nr.: 55R-011848 A50-X</p> <p>Montage door een erkende garage laten uitvoeren Deze montage-instructie moet aan de klant worden gegeven.</p> <p>Om de trekhaak te kunnen gebruiken is montage van een passende kabelset noodzakelijk. (Kabelset niet meegeleverd)</p> <p>Op de contactvlakken de tectyl, conservering van holle ruimten (was) en antireunmateriaal verwijderen.</p> <p>Waar nodig corrosiebescherming overeenkomstig de richtlijn van de TOYOTA-service aanbrengen.</p> <p>Na 1000 km gebruik van de aanhangert alle bevestigingsbouten met het voorgeschreven draaimoment vastdraaien.</p> <p>De voor het desbetreffende model auto bindend toegestane gewichten van de aanhangwagen staan in het kentekenbewijs vermeld.</p> <p>De koppelingsschakel moet schoon gehouden en ingevet worden*.</p> <p>* Uitzondering: Bij gebruik van stabilisatie-richtingen volgens de aanwijzingen van de fabrikant van de stabilisatie-richting te werk gaan. Ook moet bij het gebruik van een dergelijke stabilisatie-richting de koppelingsschakel regelmatig op slijtage worden onderzocht.</p> <p>Monteren, controleren en goedkeuring van de aanhangrichting moeten overeenkomstig de geldende wettelijke bepalingen worden uitgevoerd.</p>	<p>DK MONTERINGSVEJLEDNING FOR ANHÆNGERTRÆK</p> <p>Type: 10058570 D-Værdi: 8,6 kN Støtbelastning anhangertæk: 75 kg Producent: ACPs Automotive Kft. Kadafalva-Heliport, Hrsz.: 1175/1 H-6000 Kecskemét, Hungary Anvendelsesområde: Corolla (TS) EWG-typegodkendelse nr.: 55R-011848 A50-X</p> <p>Monteringen skal foretages af et godkendt værksted. Denne monteringsvejledning skal udleveres til kunden.</p> <p>For at kunne anvende anhangertækket kræves samtidig montering af et el-monterings sæt. (Kabelsæt ikke vedlagt)</p> <p>På anlægsfaderne skal undervognsbeskyttelsen, hulrumskonserveringen (voks) og lydæmpende materialer fjernes.</p> <p>Korrosionsbeskyttelse foretages iht. retningslinjerne fra TOYOTA-Service, hvor dette er påkrævet.</p> <p>Efter 1000 km kørsel med anhangertækket skal alle fastgørelsesskruer efterspændes med det foreskrevne drejningsmoment.</p> <p>De påhængslaster, der er tilladt for den pågældende bilmodel, kan ses i bilens papirer.</p> <p>Koblingskuglen skal holdes ren og indfedtes*.</p> <p>* UNDTAGELSE: Ved anvendelse af stabiliseringsanordninger skal man gå frem i henhold til anvisningerne fra producenten af stabiliseringsanordningen. Ligeledes skal koblingskuglen ved anvendelse af en sådan stabiliseringsanordning jævnligt undersøges for slijtage.</p> <p>Montering, test og godkendelse af anhangertækket skal gennemføres i overensstemmelse med gældende lovmæssige bestemmelser.</p>	<p>N MONTERINGSANVISNING FOR TILHÆNGERFESTE</p> <p>Type: 10058570 D-verdi: Støtbelastning tilhænger-feste: 8,6 kN Producent: ACPs Automotive Kft. Kadafalva-Heliport, Hrsz.: 1175/1 H-6000 Kecskemét, Hungary Brugsområde: Corolla (TS) EWG-typegodkjennelse: 55R-011848</p> <p>A50-X</p> <p>Monteringen må foretages av et fagverksted Denne monteringsanvisningen må overleveres til kunden.</p> <p>For bruk av tilhengerfestet er det nødvendig med samtidig montering av en elektrobyggekomponeent. (Ledningsknippe ikke inkludert)</p> <p>I festeområdet må understellsbehandlingen, hulromskonserveringen (voks) og antistøyemateriale fjernes.</p> <p>Dersom nødvendig må korrosjonsbeskyttelsen foretas i henhold til TOYOTA service-retningslinjer.</p> <p>Efter 1000 km tilhengerdrift må alle festeskruene skrues fast igjen med foreskrevet dreiemoment.</p> <p>De tilhengerlastene som gjelder for de respektive kjøretøymodellene finnes i vognkortet.</p> <p>Koblingskulan må alltid holdes ren og må smøres inn*.</p> <p>*Unntak: Ved bruk av stabiliseringsinnretninger, må</p> <p>det gås fram etter anvisning fra produsenten av disse. Likeledes må ved bruk av slike stabiliseringsinnretninger koblingskulan undersøkes med regelmessige mellomrom for slitasje.</p> <p>Montering, kontroll og tilfellest til tilhengerfestet må gjennomføres i henhold til de gyldige, lovtefte-de bestemmelsene.</p>	<p>S MONTERINGSANVISNING FÖR FÄSTE FÖR KOPPLINGSKULA</p> <p>Typ: 10058570 D-värde: Stöbelastning för drag-krok: 8,6 kN Tillverkare: ACPs Automotive Kft. Kadafalva-Heliport, Hrsz.: 1175/1 H-6000 Kecskemét, Hungary Användningsområde: Corolla (TS) EURO approval No.: 55R-011848</p> <p>A50-X</p> <p>Låt montaget utföras av en bilverkstad. Denna monteringsanvisning skall överlämnas till kunden.</p> <p>För att kunna använda släpvnagkopplingen är det nödvändigt att montera den tillhörande elektriska monteringsatsen. (Kabelset inkluderas ej)</p> <p>På anlaggningsytorna måste underredsbekhandling, hålrumskonservering (vax) och ljudisoleringsmassa avlägsnas.</p> <p>Där så erfordras skall korrosionsskydd utföras enligt riktlinjerna för TOYOTA service.</p> <p>Efter 1000 km körning med släpvnag skall alla fästskruvar efterdras med föreskrivet ådragningsmoment.</p> <p>Den för respektive bilmodell gällande högsta tillåtna släpvnagvikten framgår av bilens registreringsbevis.</p> <p>Kopplingskulan skall hållas ren och infettas*.</p> <p>* UNDTAG: Vid användning av stabiliseringsanordningar som verkar på kopplingskulan, skall man följa anvisningarna från tillverkaren av stabiliseringsanordningen. Vid användning av en sådan stabiliseringsanordning måste kopplingskulan regelbundet undersökas med avseende på slitage.</p> <p>Montering och kontroll av släpvnagkopplingen måste utföras enligt gällande lagstadgade bestämmelser.</p>
<p>SF VETOLAITTEEN ASENNUSOHJE</p> <p>Tyyppi: 10058570 D-arvo: 8,6 kN Vetokoukun suurin vertikaalinen työntökyky: 75 kg Valmistaja: ACPs Automotive Kft. Kadafalva-Heliport, Hrsz.: 1175/1 H-6000 Kecskemét, Hungary Corolla (TS) EWG-tyyppihyväksyntä nr.: 55R-011848 A50-X</p> <p>Asennuksen suorittaa merkkikorjaamo</p> <p>Tämä asennusohje annetaan asiakkaalle.</p> <p>Vetolaitteeseen käytetään varten on tarpeen asentaa samanaikaisesti sähkösarjaa. (Kaapelisetti ei kuulu toimitukseen)</p> <p>Asennuskohdista on poistettava pohjamaalaus, tyhjän tilan säilöntä (vaha) ja melunestoaine.</p> <p>Korroosiosuojaa käytetään tarvittavissa kohdissa TOYOTA huollon antamien ohjeiden mukaan.</p> <p>Kiristä kaikki kiinnitysruuvit määrättyllä vääntömomentilla, kun vetokoukku on ollut käytössä 1000 km.</p> <p>Jokaisen ajoneuvomallin silovut sallitut vetokoukumat on ilmoitettu ajoneuvon paperissa.</p> <p>Kytkimen nappi on pidettävä puhtaana ja rasvatta va*.</p> <p>* POIKKEUS: Käytettäessä vakauslaitteita menettään vakauslaitteen valmistajan antamien ohjeiden mukaan. Samoin on käytettäessä vakauslaitetta tarkastettava kytkimen nupin kulumien säännöllisin väliajoin.</p> <p>Vetolaitteeseen asennus, tarkastus ja hyväksyntä on tehtävä voimassa olevien lakien ja säännösten mukaan.</p>	<p>CZ INSTRUKCE K MONTÁŽI ZÁVŮSNĚHO</p> <p>Typ: 10058570 Hodnota D: 8,6 kN Maximální vertikální spojovací zařízení závažného háku: 75 kg Výrobce: ACPs Automotive Kft. Kadafalva-Heliport, Hrsz.: 1175/1 H-6000 Kecskemét, Hungary Corolla (TS) 55R-011848</p> <p>A50-X</p> <p>Nechte montáž provést ve specializované dílně</p> <p>Tuto montážní instrukci je třeba předat zákazníkovi.</p> <p>Pro provoz závěsného zařízení je zapotřebí současně instalace montážní soupravy elektro. (Sada kabelů se nedodává společně s výrobkem)</p> <p>V oblasti ploch zařízení je třeba odstranit ochranu podvozku proti korozi, konzervaci dutin (vosk) a tlumiči proušedek.</p> <p>Kde je to zapotřebí, ošetřete ochranným prostředkem proti korozi podle Servisní směrnice TOYOTA.</p> <p>Po 1000 km provozu s přívěsem dotáhně všechny šrouby předepsaným uťahovacím momentem.</p> <p>Dovolené hmotnosti přívěsu pro příslušný model vozidla jsou uvedeny v dokladech k vozidlu.</p> <p>Kouli spojky je třeba udržovat v čistotě a mazat jí*.</p> <p>* VÝJIMKA: Při použití stabilizačních zařízení postupujte podle pokynů výrobce stabilizačního zařízení. Rovněž je třeba při použití takového stabilizačního zařízení v pravidelných intervalech kontrolovat opotřebení koule spojky.</p> <p>Montáž, kontrola a povolení závěsného zařízení musí odpovídat platným zákonným ustanovením.</p>	<p>H A LESZERELHETŐ VONTATÓBERENDEZÉS FELSZERELÉSI</p> <p>Tipus: 10058570 D-érték: 8,6 kN A vontatórúd max. függőleges összekapcsolási terhelése: 75 kg Gyártó: ACPs Automotive Kft. Kadafalva-Heliport, Hrsz.: 1175/1 H-6000 Kecskemét, Hungary Corolla (TS) EGK-típusengedély száma: 55R-011848 A50-X</p> <p>Ezt a munkát csak egy szakműhellyel szabad elvégezni. Kérjük adja át ezt a felszerelési utasítást a Vevőnek.</p> <p>A vontatóberendezés üzemeltetéséhez egy megfelelő elektromos szerelékészletet is be kell építeni. (A vezetékcsomag nincs a szállítmányban!)</p> <p>A felfekvési felületéknél és azok közvetlen környezetében el kell távolítani az alvázvédőréteget, az üregkitöltő konzerválóanyagokat (viaszt) és a berezgőgátó borítást.</p> <p>Ahol szükséges, a felületeket a TOYOTA-szerviz előírásainak megfelelő korrózióvédelemmel kell ellátni.</p> <p>Miután a vontatóberendezéssel és utánfutóval 1000 km-t meglett, az előírt forgatóanyagot kell ismét hűzta meg az összes rögzítőcsavart.</p> <p>A mindenkorú gépjárműmodellhez megengedett vontatható maximális súly a gépjármű forgalmi engedélyében található.</p> <p>A kuplunggömböt mindig tisztán kell tartani és be kell zsírozni*.</p> <p>* KIVÉTEL: Ha stabilizálóberendezést használ, akkor a stabilizálóberendezést gyártó cég előírásainak megfelelően kell eljárni. Ilyen esetekben a kuplunggömb kopását rendszeres időközönként ellenőrizni kell.</p> <p>A vontatóberendezés felszerelését, ellenőrzését és engedélyezését az érvényben lévő törvényes előírásoknak megfelelően kell végrehajtani.</p>	<p>PL INSTRUKCJA MONTAŻU WYPOSAŻENIA HOLOWNICZEGO</p> <p>Typ: 10058570 Wartość-D: 8,6 kN Maksymalne pionowe obciążenie zosa drga holowniczego: 75 kg Producent: ACPs Automotive Kft. Kadafalva-Heliport, Hrsz.: 1175/1 H-6000 Kecskemét, Hungary Corolla (TS) Nr. zezwolenia EWG: 55R-011848 A50-X</p> <p>Montaż zwoić specjalistycznemu warsztatowi Niniejsza instrukcja należy wręczyć klientowi.</p> <p>W celu eksploatacji wyposażenia holowniczego, konieczne jest jednoczesne zamontowanie modułu elektrycznego. (Zestaw kablowy nie jest dołączony)</p> <p>W strefie powierzchni przylegania musi być usunięte zabezpieczenie podłogi, zabezpieczenie przestrzeni wewnętrznych (wosk) oraz materiały wyciszające.</p> <p>Tam, gdzie to konieczne, wykonaj zgodnie z zaleceniami serwisu firmy TOYOTA zabezpieczenie antykorozyjne.</p> <p>Po 1000 km użytkowania przyczepty należy doreczyć wszystkie śruby mocujące stosując przy tym przepisany moment dokręcający.</p> <p>Obowiązujące, dopuszczalne do doczepiania ciężary są podane dla każdego modelu pojazdu w jego dokumentach.</p> <p>Sprzęg kulowy należy utrzymać w czystości i smarować go.</p> <p>*WYJĄTEK: W przypadku używania wyposażenia stabilizującego należy postępować zgodnie ze wskazówkami producenta tego wyposażenia. Także przy używaniu takiego wyposażenia, sprzęg kulowy musi być regularnie poddawany kontroli na stan jego użycia.</p> <p>Montaż, kontrola i udzielenie zezwolenia dla wyposażenia holowniczego musi być dokonywane zgodnie z ważnymi postanowieniami prawnymi.</p>











<p>RO INSTRUCTIUNI DE MONTARE - BARĂ DE TRACTARE</p> <p>Tip: 10058570 Valoare D: 8,6 kN Sarcina barei de tractare la cuplarea verticală: 75 kg Producător: ACPs Automotive Kft. Kadafalva-Heliport, Hrsz.: 1175/1 H-6000 Kecskemét, Hungary</p> <p>Aplicare model: Corolla (TS) Nr. aprobare tip CE: 55R-011848</p> <p>A50-X</p> <p>Este necesară montarea de către un specialist. Asigurați-vă că aceste instrucțiuni de montare sunt înmânate clientului.</p> <p>Pentru a utiliza cârligul de remorcare, este necesară instalarea simultană a unui kit electric. (Setul de cabluri nu este inclus)</p> <p>Îndepărtați învelișul de ceară anticorozivă și materialul antifonant în zona suprafețelor de contact.</p> <p>Unde este necesar aplicați material de protecție anticorozivă după cum este specificat în ghidul de service TOYOTA.</p> <p>După aproximativ 1000 km de utilizare a remorcii, restrângeți toate șuruburile la valoare de cuplu corectă.</p> <p>Pentru sarcinile de remorcare corecte consultați documentele vehiculului în funcție de model. Bila de cuplare trebuie menținută curată și bine lubrifiată.</p> <p>*EXCEPȚIE: Când se utilizează stabilizatori, respectați instrucțiunile producătorului acelor stabilizatori. În acest caz bila de cuplare trebuie inspectată pentru uzură la intervale regulate.</p> <p>Sistemul de cuplare al remorcii trebuie instalat și inspectat în conformitate cu reglementările naționale în vigoare.</p>	<p>SK POKYNY PRE MONTÁŽ - ŤAŽNÉ ZARIADENIE</p> <p>Typ: 10058570 Hodnota D: 8,6 kN Maximálne vertikálne zaťaženie ťažného zariadenia: 75 kg Výrobca: ACPs Automotive Kft. Kadafalva-Heliport, Hrsz.: 1175/1 H-6000 Kecskemét, Hungary Corolla (TS) 55R-011848</p> <p>Použitie na model: A50-X Schválenie typu EK .:</p> <p>Vyžaduje sa montáž odborníkom Uistite sa, že tieto pokyny pre montáž budú odovzdané zákazníkovi.</p> <p>Pre použitie ťažného zariadenia je súčasne potrebná inštalácia elektrickej výbavy. (Set káblov nie je súčasťou dodávky)</p> <p>V priestore styčných plôch je potrebné odstrániť tenšie, protikorozný vosk a materiál na tlenie hluku.</p> <p>Podľa potreby aplikujte materiál na ochranu pred koróziou tak, ako je uvedený v servisných smerniciach TOYOTA.</p> <p>Približne po 1000 km používania príviesu dotiahnite všetky skrutky na správne hodnoty krútiaceho momentu.</p> <p>Informácie o povolených hmotnostiach príviesov možno nájsť v dokumentoch k danému modelu vozidla.</p> <p>Ťažná guľa musí byť udržiavaná v čistej a namazaná vazelínou.</p> <p>*VNIIMKA: Ak sa používajú stabilizátory, postupujte podľa pokynov výrobcu stabilizátorov. V takom prípade sa ťažná guľa musí v pravidelných intervaloch kontrolovať na opotrebovanie.</p> <p>Ťažné zariadenie sa musí namontovať a skontrolovať v súlade s platnými národnými predpismi.</p>	<p>RUS ИНСТРУКЦИЯ ПО МОНТАЖУ БУКСИРНОГО КРЮКА</p> <p>Модель: 10058570 Коэффициент D (определяется по массе автомобиля и прицепа): 8,6 kN Вертикальная нагрузка на буксирный крюк: 75 kg Производитель: ACPs Automotive Kft. Kadafalva-Heliport, Hrsz.: 1175/1 H-6000 Kecskemét, Hungary Corolla (TS) 55R-011848</p> <p>Диапазон использования: Номер разрешения по нормам ЕС для данной модели: A50-X</p> <p>Монтаж должен выполняться сертифицированной автомастерской. Настоящая инструкция по монтажу должна предоставляться заказчику.</p> <p>Для того чтобы буксирный крюк можно было использовать, необходимо смонтировать соответствующие данной модели провода (провода в комплект поставки не входят!)</p> <p>Удалить воск с контактных поверхностей, средства консервации (восковой состав) из полостей и антишумовой материал.</p> <p>Если необходимо, нанести антикоррозийное покрытие в соответствии с нормами сервиса для моделей TOYOTA.</p> <p>После пробега прицепом 1000 км затянуть все крепящие болты, используя ключ с заданным крутящим моментом.</p> <p>Допустима для данной модели автомобиля масса прицепа указанная в техническом паспорте автомобиля. Сцепной шар должен быть чистым и покрыт смазкой.</p> <p>* ИСКЛЮЧЕНИЕ: при использовании стабилизирующих приспособлений руководствоваться указаниями производителя данных приспособлений. В случае применения подобных стабилизирующих приспособлений регулярно проверять износ сцепного шара.</p> <p>Монтаж, контроль и сертификация прицепа должны выполняться в соответствии с действующими законоположениями.</p>	<p>TR ÇEKİ DEMİRİ MONTAJ TALİMATLARI</p> <p>Tipi: 10058570 D-değeri: 8,6 kN Çeki demirinin dikey çekme yükü: 75 kg İmalatçı: ACPs Automotive Kft. Kadafalva-Heliport, Hrsz.: 1175/1 H-6000 Kecskemét, Hungary</p> <p>Uygulama alanı: Avrupa Ekonomik Topluluğu Corolla (TS) (EEG) onay numarası: 55R-011848</p> <p>A50-X</p> <p>Montaj onayı bir oto tamircisinde yapın Bu montaj talimatları müşteriye veriliyor olmalıdır.</p> <p>Çeki demirini kullanmak için uygun kablo takımı çekmeye karşı maddesi uzatılmamıştır.</p> <p>Gerekliğinde sürünmeye karşı kurumayı TOYOTA servis kurallarıyla uyumlu olarak sürün.</p> <p>Yaklaşık 1000 km kullandıktan sonra bütün somun ve civataları talimatlara uygun olarak tekrar sıkın.</p> <p>Her model için geçerli olan çekme ağırlıkları araba ruhsat evrakında belirtilmiştir.</p> <p>Çeki demiri topuzu temiz tutulmalı ve yağlanmalıdır.</p> <p>* İSTİSNA: Sabitleme aletlerinin kullanılması durumunda, bu sabitleme aletinin üreticisinin kurallarına göre davranın. Sabitleme aletlerinin kullanılması durumunda da çeki demiri topuzunu düzenli olarak aşınmaya karşı kontrol edilmesi gerekir.</p> <p>Çeki demiri ve çekme araba için kontrol ve kurallarına göre yapılmalıdır.</p>
<p>BG Инструкции за монтаж – ТЕГЛИЧ</p> <p>Тип: 10058570 D-стойност: 8,6 kN Вертикално свързване на товарият еглиц: 75 kg Производител: ACPs Automotive Kft. Kadafalva-Heliport, Hrsz.: 1175/1 H-6000 Kecskemét, Hungary</p> <p>Модел на приложението: Corolla (TS) ЕС-тип одобрение №: 55R-011848</p> <p>A50-X</p> <p>Монтажът трябва да се извърши от специалисти. Направете така, че тези инструкции за монтаж да се предадат на клиента.</p> <p>За да използвате прикритото устройство на ремаркет е необходимо едновременно да монтирате и електрическата инсталация. (Кабели не са включени!)</p> <p>Махнете подложения за уплътнение антикорозионен восък и шумоизолация материал около контактните повърхности.</p> <p>Нанесете материал за защита от корозия там, където е необходимо, както е посочено в ръководството за обслужване на TOYOTA.</p> <p>След около 1000 km използване на ремаркет, затегнете всички болтове до правилните стойности на въртящия момент.</p> <p>За правилни натоварвания на ремаркет, моля, вижте документите на превозното средство според индивидуалния модел.</p> <p>Сферичният шарнир трябва да се пази чист и добре смазан.</p> <p>*ИСКЛЮЧЕНИЕ: Когато се използват стабилизатори, действат според инструкциите на производителите на стабилизатора. В този случай сферичният шарнир трябва да се преглежда за износване на определени интервали.</p> <p>Съединителният механизъм на ремаркет трябва да се монтира и проверява в съответствие с приложимите национални разпоредби.</p>	<p>EST TIISLI PAIGALDUSJUHISED</p> <p>Tüüp: 10058570 D-väärtus: 8,6 kN haakeseadmele: 75 kg Tootja: ACPs Automotive Kft. Kadafalva-Heliport, Hrsz.: 1175/1 H-6000 Kecskemét, Hungary</p> <p>Sobiv mudel: Corolla (TS) EU tüübikinnituse nr: 55R-011848</p> <p>A50-X</p> <p>Vajalik on professionaalne paigaldus Veenduge, et klient saab paigaldusjuhised kätte.</p> <p>Haakeseadmele käsutamiseks tuleb samaaegselt paigaldada ka elektrikomplekt. (Kaablikomplekt ei kuulu varustusel)</p> <p>Eemaldage kokkuputeepindadelt aluskate, korrosioonivastane vaha ja mürasummutusmaterjal.</p> <p>Kandke vajalikesse kohtadesse korrosioonikaitse vahendit vastavalt TOYOTA hooldusjuhistele.</p> <p>Pärast liigikaudu 1000 km haagise kasutust, keerake kõik poidid uuesti õigete jõumomendile.</p> <p>Haagisele sobivaid koormusi vaadake palun vastava sõidukimudeli dokumentidest. Jälgige, et ühenduspalli oleks puhast ja määritud.</p> <p>*ERAND: Kui kasutate stabilisaatoreid, siis jätkake vastavalt stabilisaatori tootja juhistele. Sellisel juhul peab ühenduspalli regulaarselt ajavahemike tagant kontrollima.</p> <p>Haakeseadet tuleb paigaldada ja kontrollida vastavalt kehtivale riiklikele määrustele.</p>	<p>LV BUKSĒŠANAS STIENA IEKĀRTAS UZSTĀDĪŠANAS INSTRUKCIJA</p> <p>Tips: 10058570 Koeficients D (nosaka pēc automobiļa un autopiķekabes masas): 8,6 kN Vertikālā slodze uz buksēšanas stieņa iekārtas: 75 kg Ražotājs: ACPs Automotive Kft. Kadafalva-Heliport, Hrsz.: 1175/1 H-6000 Kecskemét, Hungary</p> <p>Lietošanas diapazons: Corolla (TS)</p> <p>Eiropas Kopienas tipa atļauja Nr.: 55R-011848</p> <p>A50-X</p> <p>Buksēšanas stieņa iekārtas uzstādīšana jāveic sertificētā automobiļu mehāniķim. Lūdzu, nodrošiniet šīs uzstādīšanas instrukcijas nodošanu klientam.</p> <p>Lai lietotu buksēšanas stieņa iekārtu, nepieciešams uzstādīt attiecīgos elektriskos komponentus. (Vadī komplektā nav iekļauti)</p> <p>Neņemiet no kontakta virsmām nehermētisko blīvējumu, pretkorozijas vasku un trokšņus slāpējošo materiālu.</p> <p>Ja nepieciešams, apstrādājiet virsmas ar pretkorozijas materiālu, kā norādīts "TOYOTA" servisa norādēs.</p> <p>Pēc aptuveni 1000 km nobraukšanas ar autopiķekabi pārbaudiet, vai visas buļtskrūves ir pievilktas līdz pareizajam griezes momentam. Lai iegūtu informāciju par autopiķekabes atļautajām slodzēm, lūdz, skatiet attiecīgā transportlīdzekļa modeļa dokumentāciju. Savienojējiet lodei jābūt tīrai un pietiekami ieeļļotai.*</p> <p>*PIEZĪME: lietojot stabilizatorus, rīkojieties saskaņā ar stabilizatora ražotāja instrukciju. Regulāri pārbaudiet, vai savienojšā lode nav pārmērīgi nodulusi. Autopiķekabes savienojums jāizveido un jāpārbauda atbilstoši saistošajiem likuma noteikumiem.</p>	<p>LT TVIRTINIMO INSTRUKCIJOS - TEMPIMO STRYPAS</p> <p>Tipas: 10058570 D-reikšmė: 8,6 kN Vertikalus jungimo tempimo juosta: 75 kg Vertikalus jungimo transporto priemonė: 50kg Gamintojas: ACPs Automotive Kft. Kadafalva-Heliport, Hrsz.: 1175/1 H-6000 Kecskemét, Hungary</p> <p>Naudojamas modelis: Corolla (TS) EB Tipu patvirtinimo nr.: 55R-011848</p> <p>A50-X</p> <p>Reikia patyrisio tvirtintojos Istikinkite, kad šios tvirtinimo instrukcijos bus pateikiamos klientui.</p> <p>Norint naudotis priekaba, kartu reikia sumontuoti ir elektros rinkinį. (Kabeliai nepriededami)</p> <p>Nuo kontaktuojančių paviršių nuimkite apatinį sandariklio sluoksnį, antikorozinį vašką ir triukšmą šalinančią medžiagą.</p> <p>Kur reikia, uždekite apsaugančią nuo korozijos medžiagą, kaip nurodyta „TOYOTA“ priežiūros instrukcijoje.</p> <p>Kai priekaba nuvažiuos maždaug 1000 km, iš naujo tinkamai priveržkite visus varžtus.</p> <p>Dėl tinkamos priekabos apkrovos žiūrėkite atskirų modelių dokumentus. Jungties rutulys turi būti švarus ir gerai suteptas.</p> <p>*ŠIMTIS: jei naudojami stabilizatoriai, laikykitės stabilizatoriaus gamintojo pateiktų reguliarių tikrinimų, ar jungties rutulys nusudėjęs.</p> <p>Priekabos jungtis turi būti montuojama ir apžiūrima pagal galiojančius vietinius reikalavimus.</p>

Revision record

Rev. No.	Date	Page	Step	Update
△1	06.09.2019	25	25	TREK variant added
△1	06.09.2019	6	KIT	Kit update
△2	24.01.2020	22, 23	22, 23	Updated

PW960-02007

PW960-02020

- | | | | |
|----------|---|----------|--|
| A |  (8x) (M12)x1,25x40-10.9 | F |  (1x) M6 |
| B |  (8x) M12 | G |  (1x) M6 - PA 6.6 (Plastic) |
| C |  (4x) 40x12,5x5 | H |  (1x) M6 (Steel) |
| D |  (1x) Segment A | I |  (1x) (M6)x30-10.9 |
| E |  (1x) Segment B | J |  (2x) Plastic Tie-Wrap |

PW960-02023

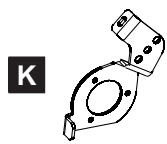

PW960-02021









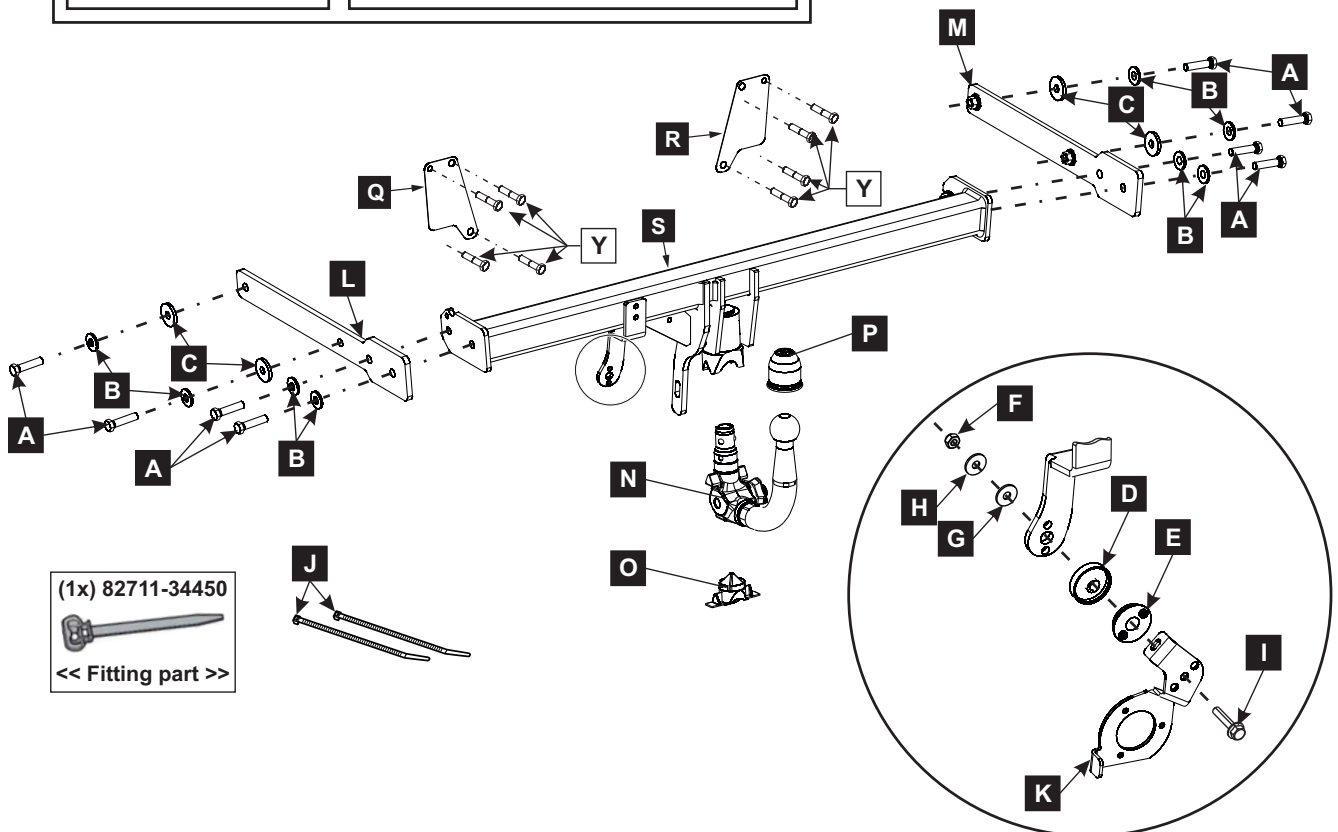







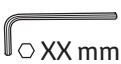





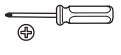

PW960-05007



PZ488-00551-00



 =  XX mm	 = 	 = 
 =  XX mm	 = 	 = 
 = 	 = 	 = 
 =  TXX	 = 	 = START

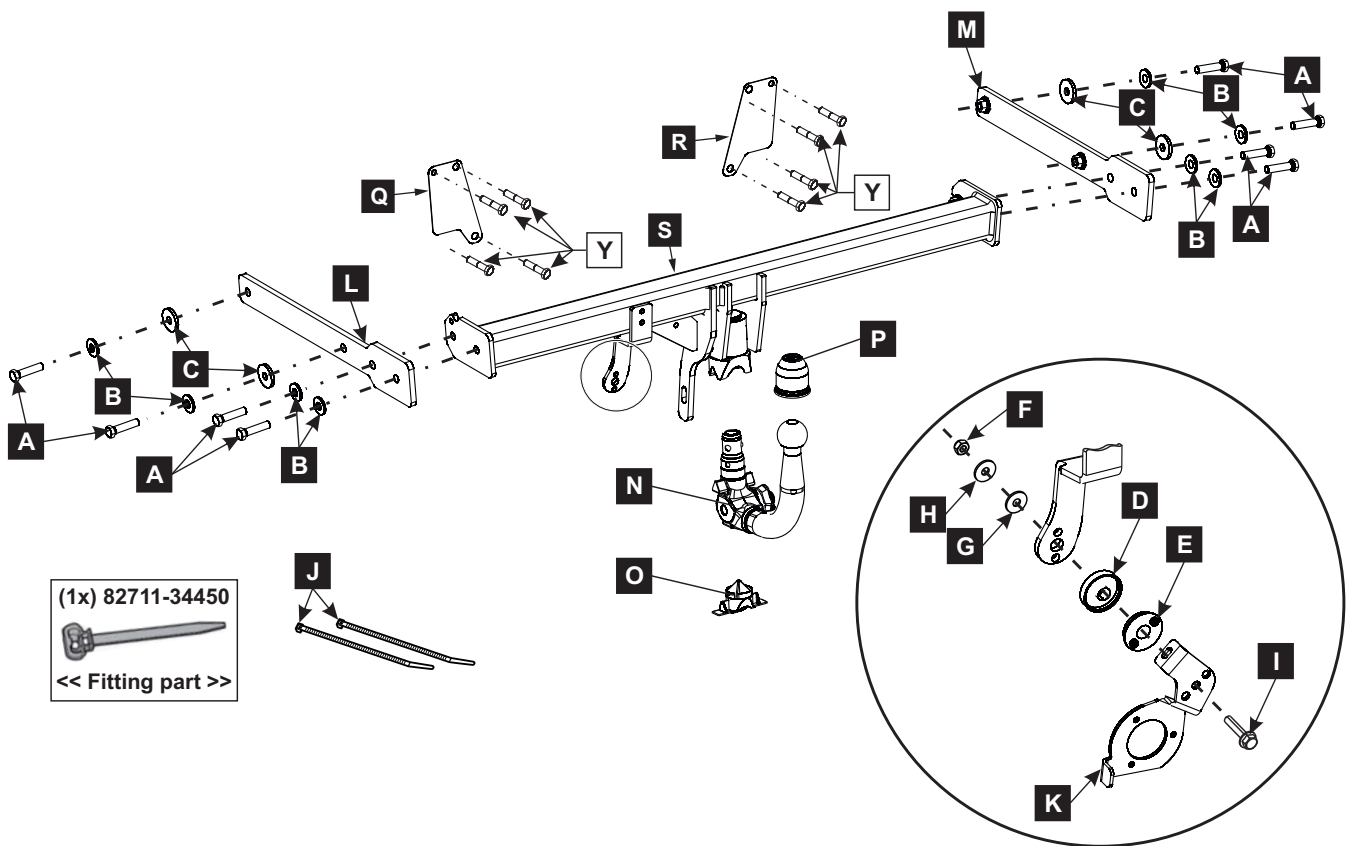

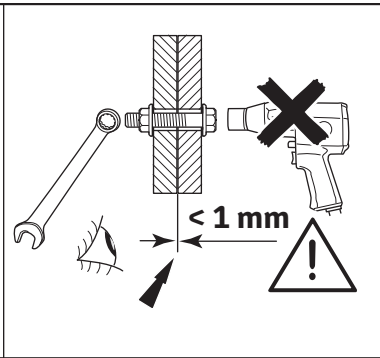
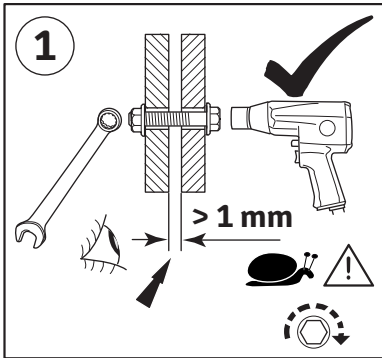
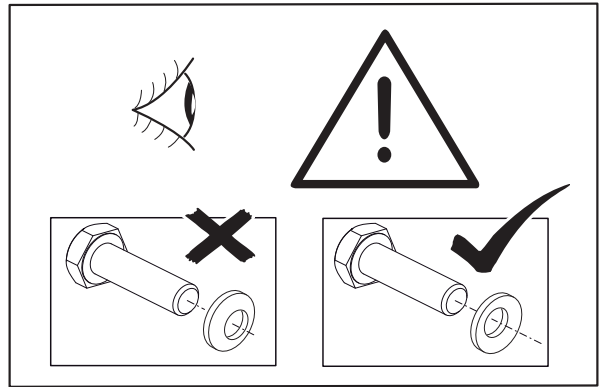
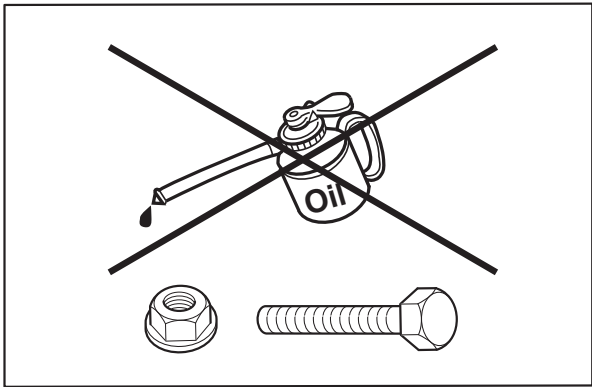

Material Safety Data Sheet





Technical Data Sheet

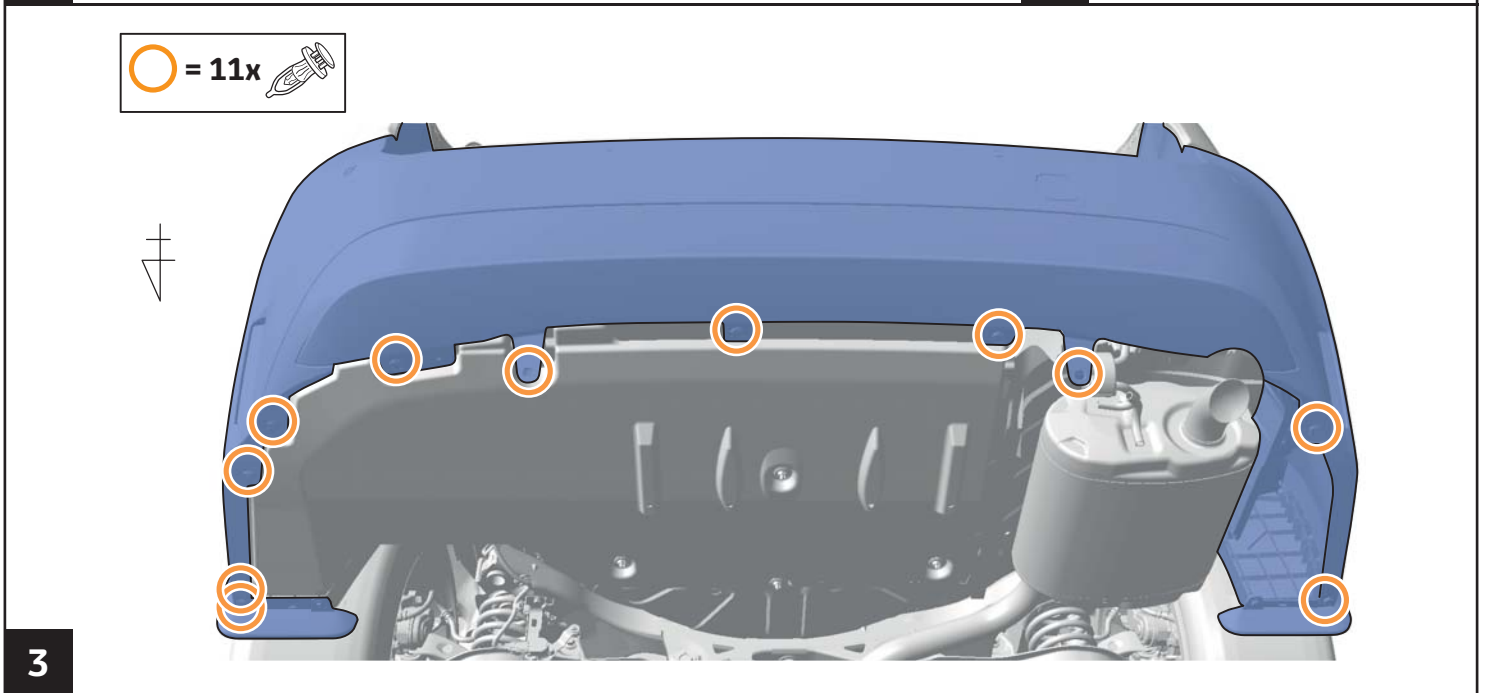
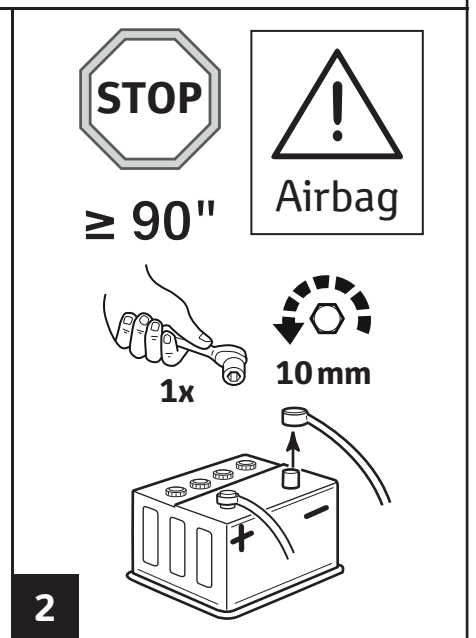
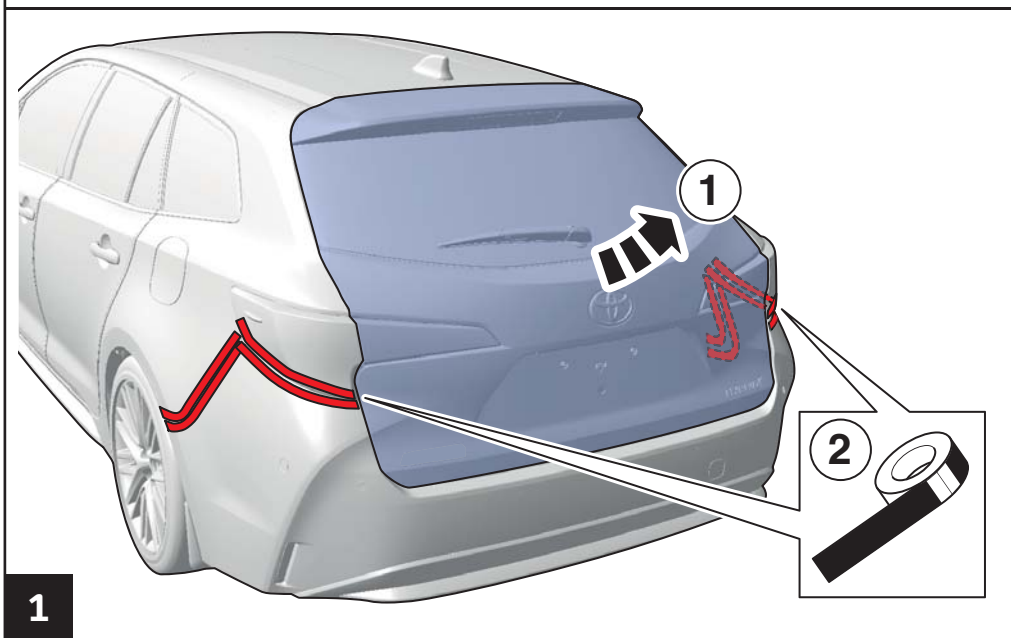

			X Fe ✓ ABS		AIM 003-516-+	
Under Coating Protection 			19 mm			 Click
			5 mm			19 mm
				 10mm 12mm 19mm	 10mm 12mm 19mm	



LHS=RHS

 = 2x  10 mm

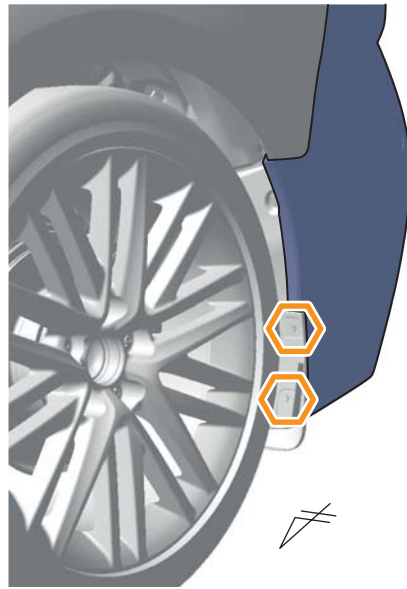

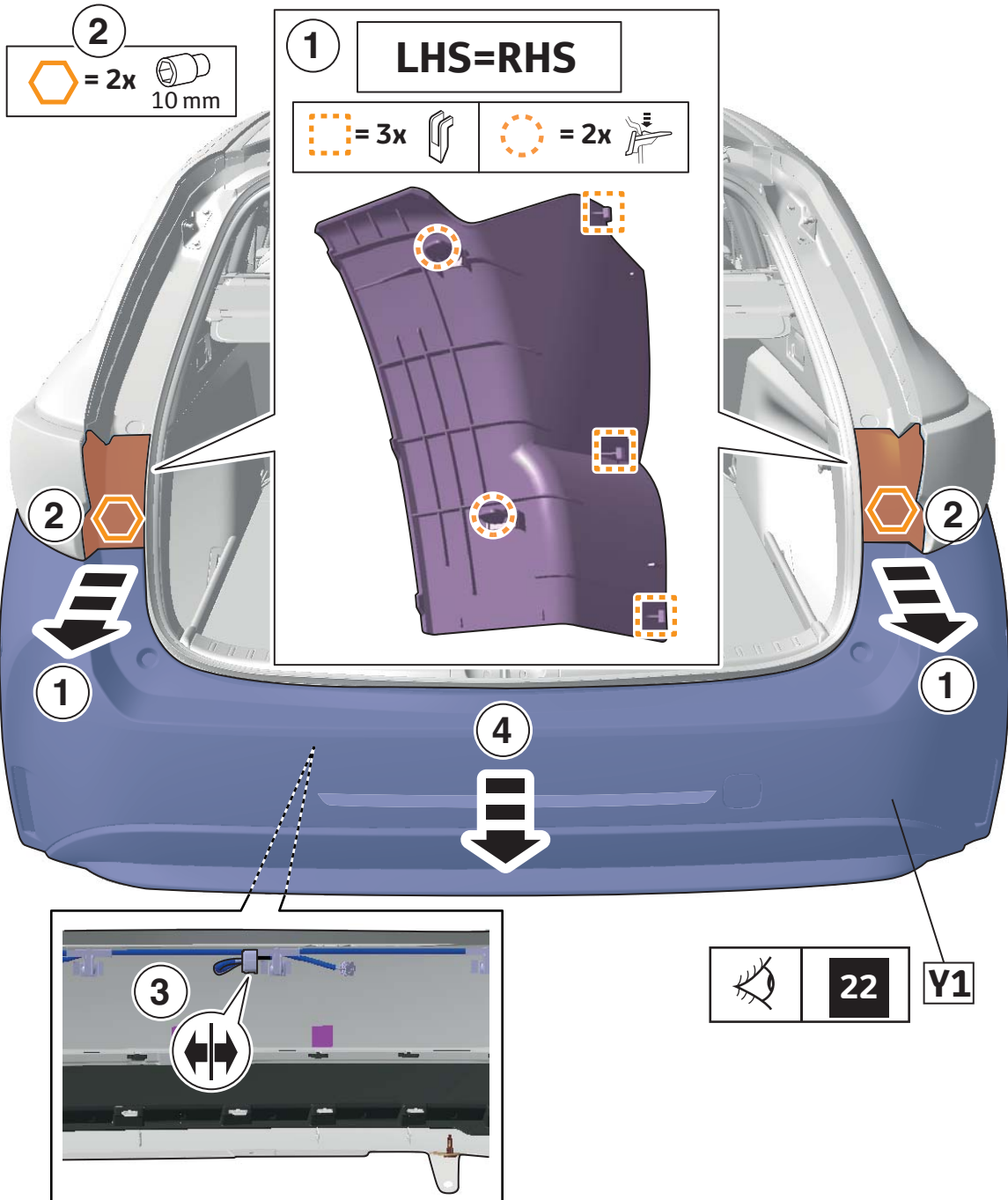

4



5

 = 1x 

 = 4x 
12 mm



26

Y3

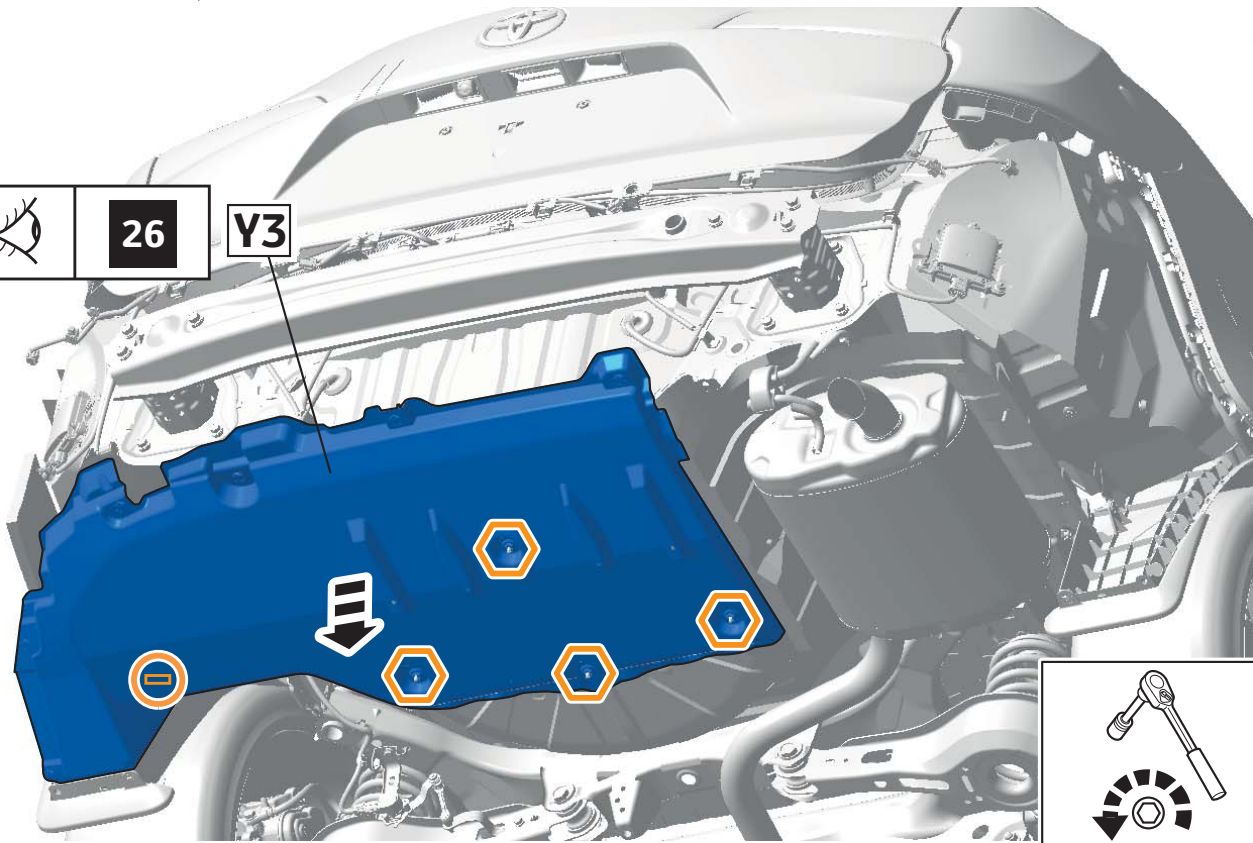

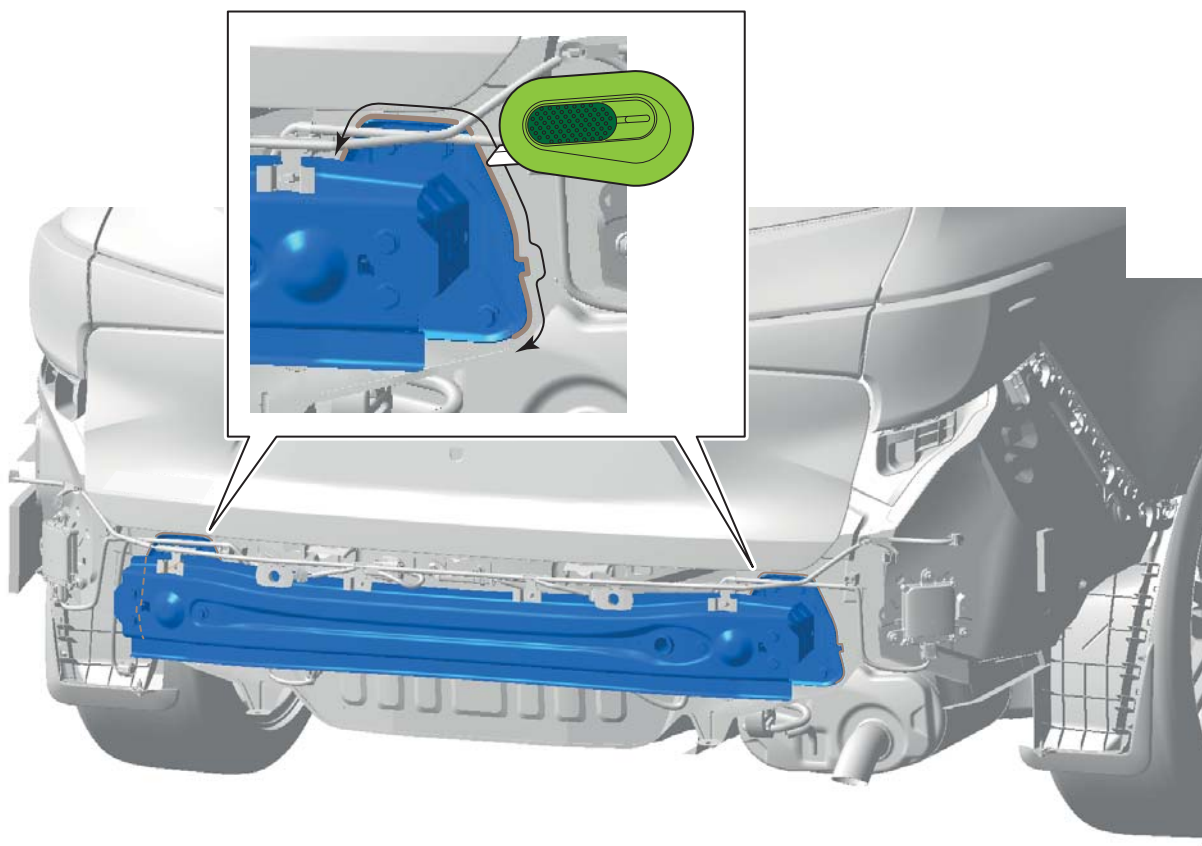

6



7

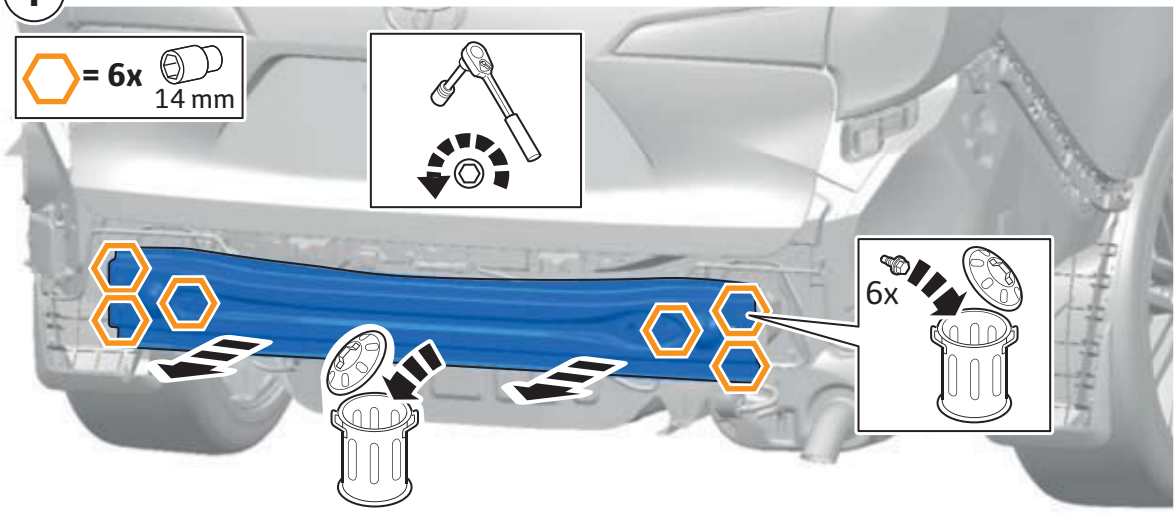
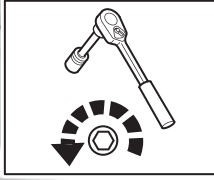

1

 = 6x  14 mm



6x 

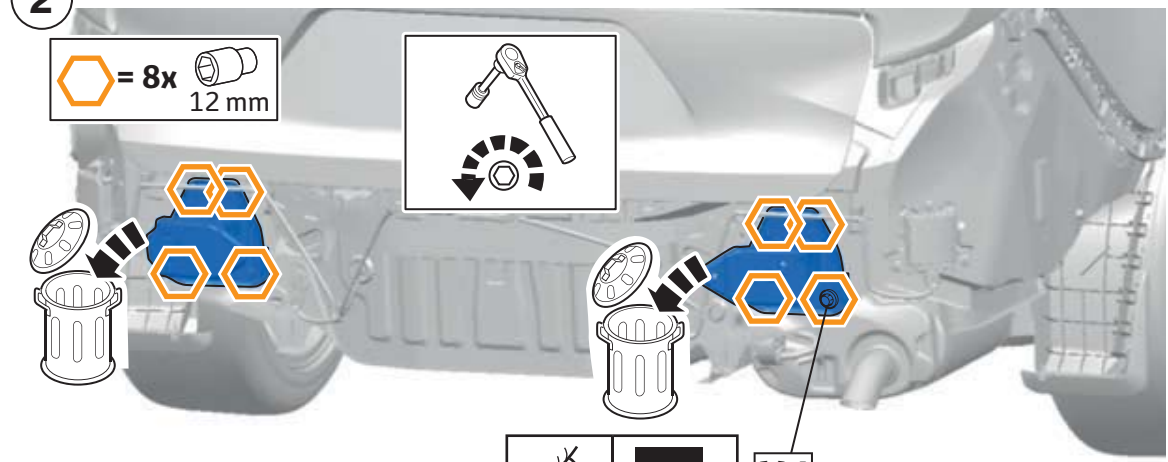
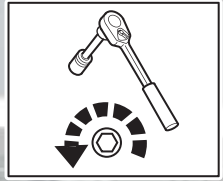

2

 = 8x  12 mm



 **12** **Y4** 8x

8

 = 3x  10 mm

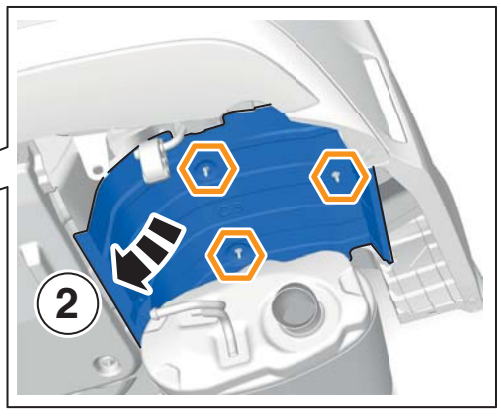
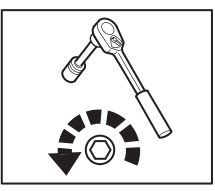

2

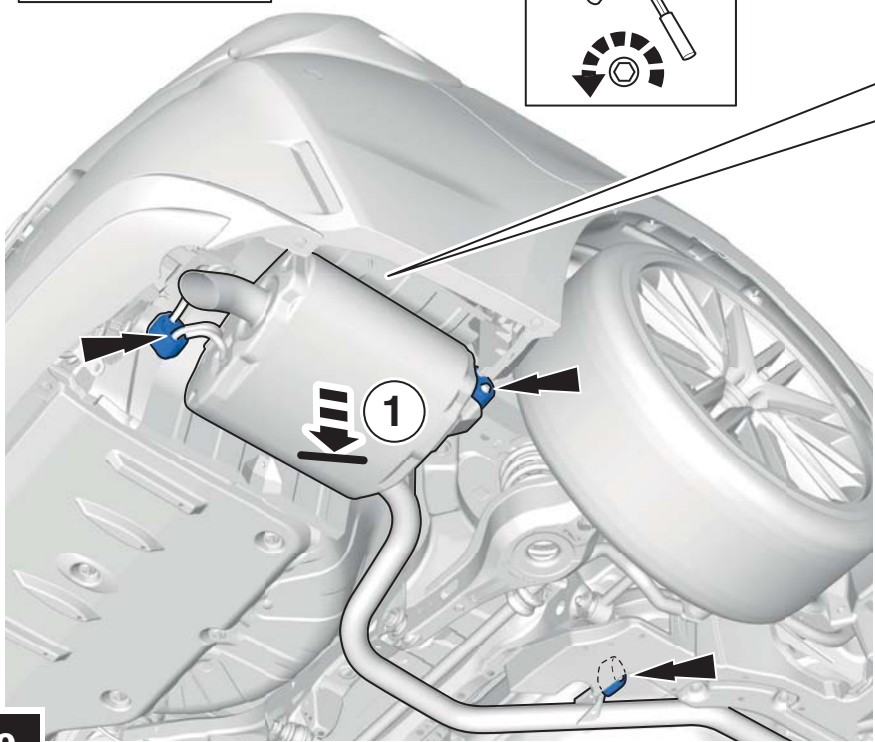
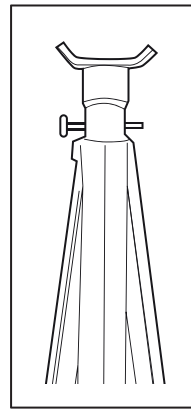

1

9

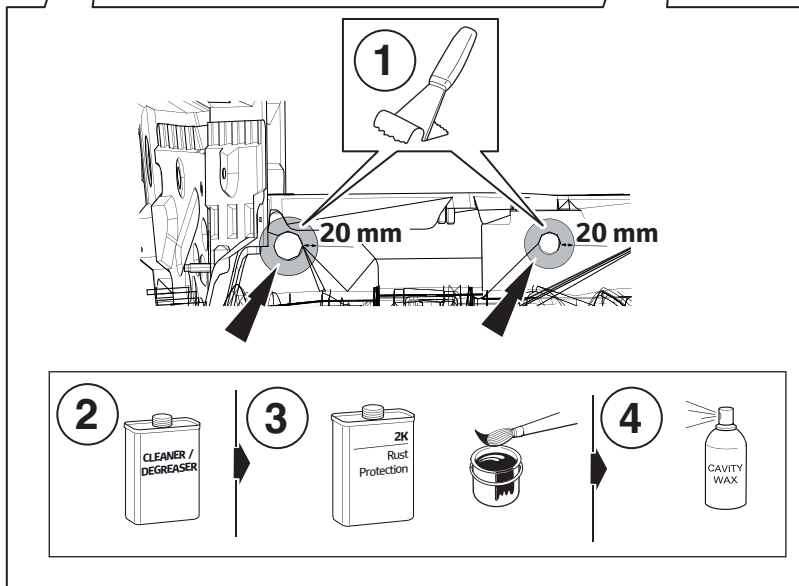
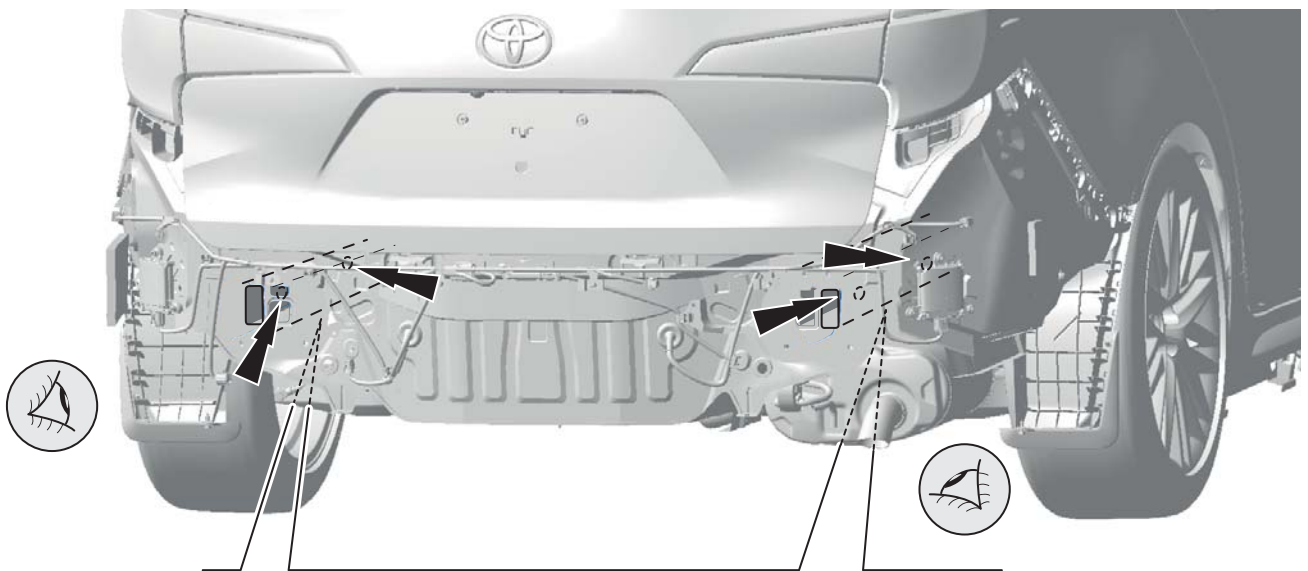

10

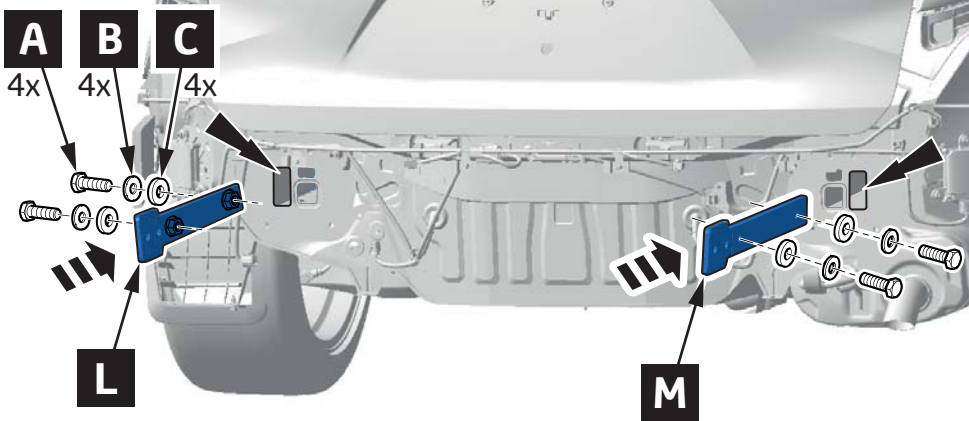
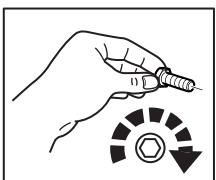
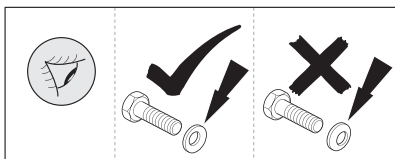

11

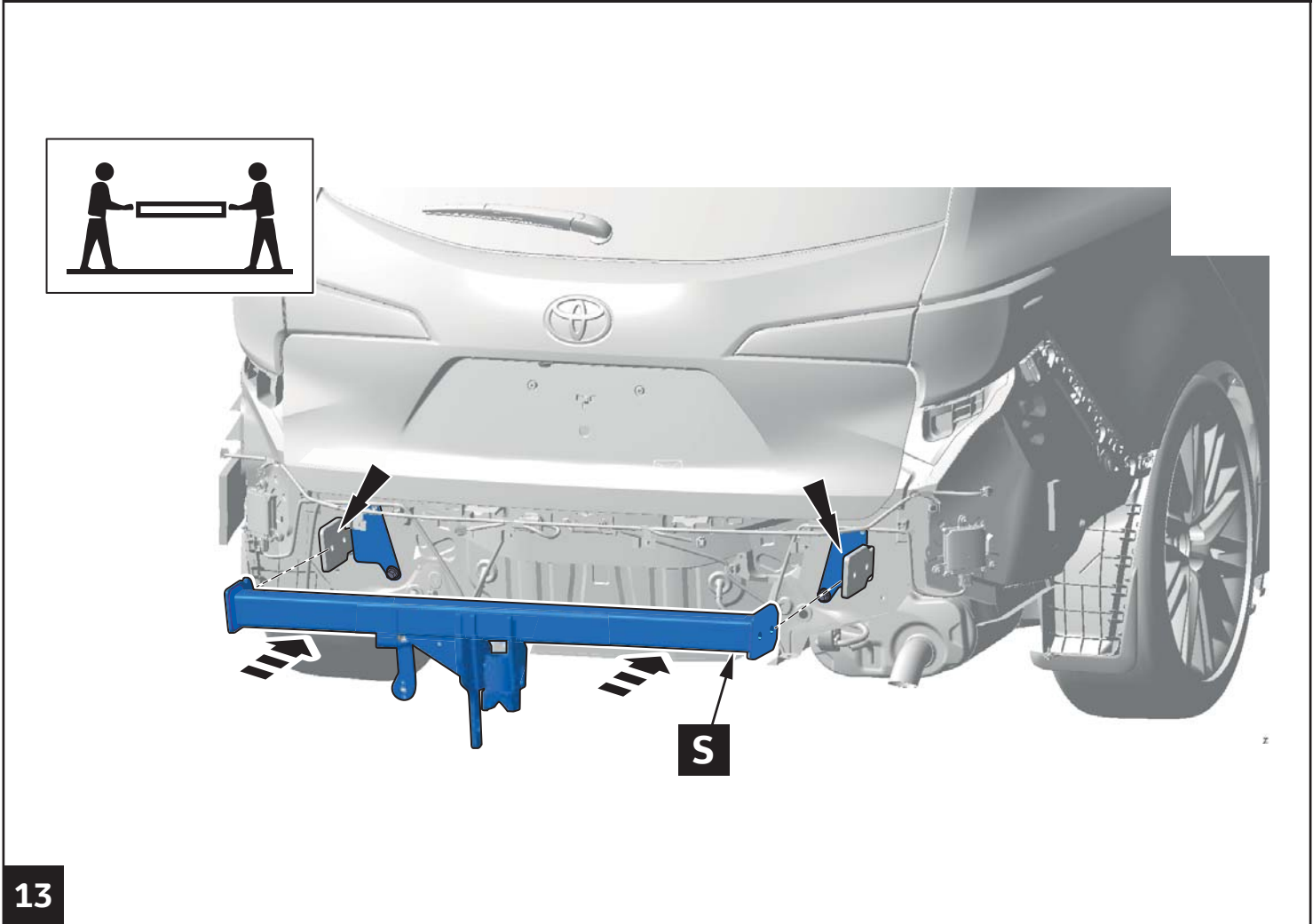
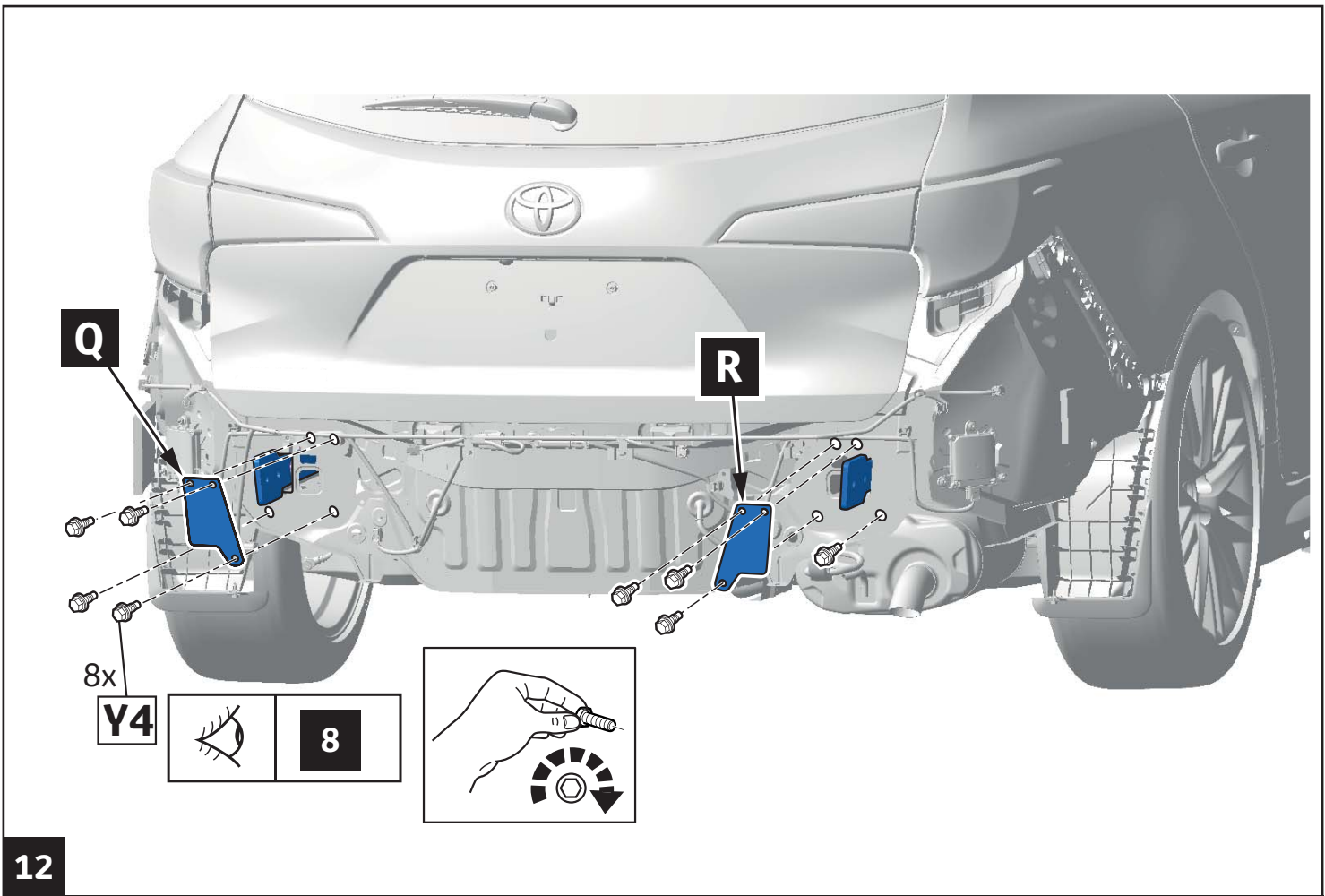

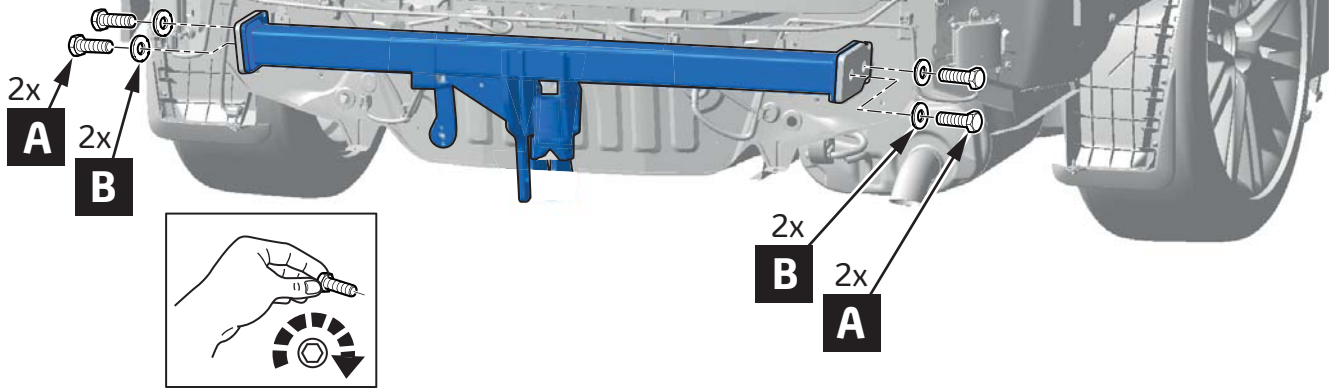
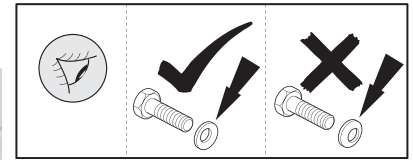
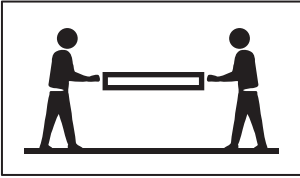

14

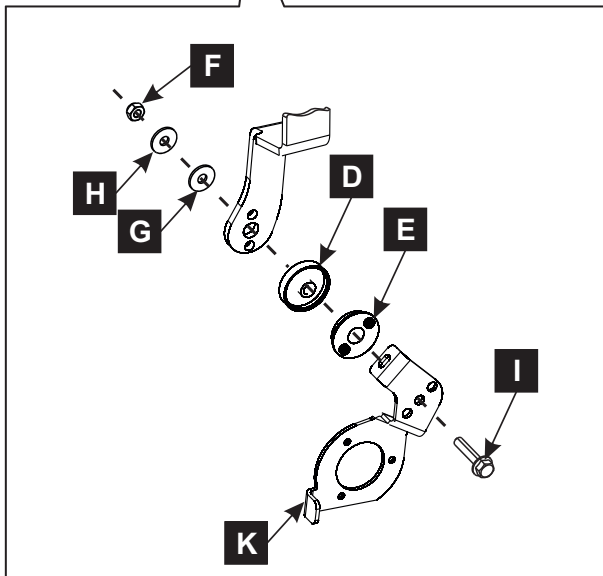
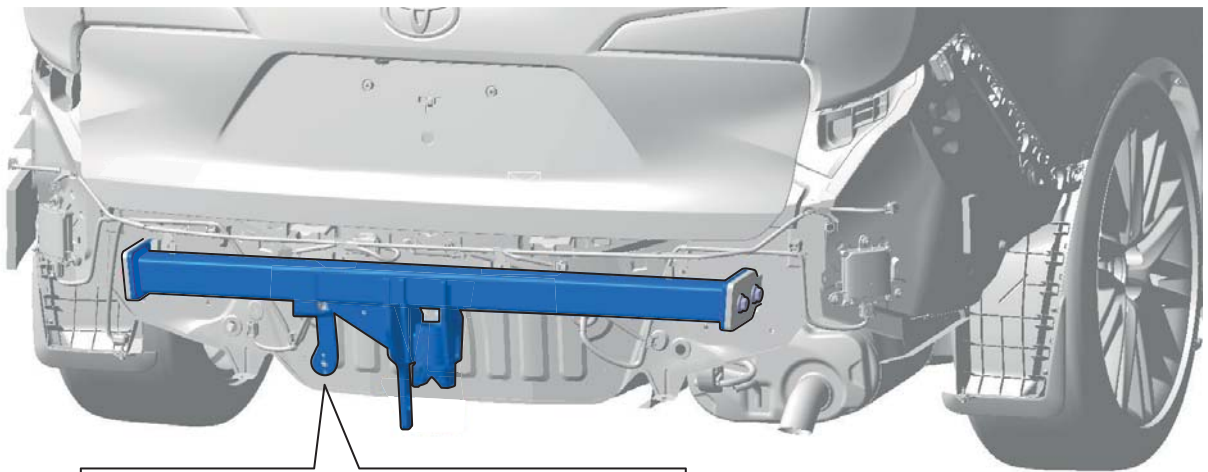



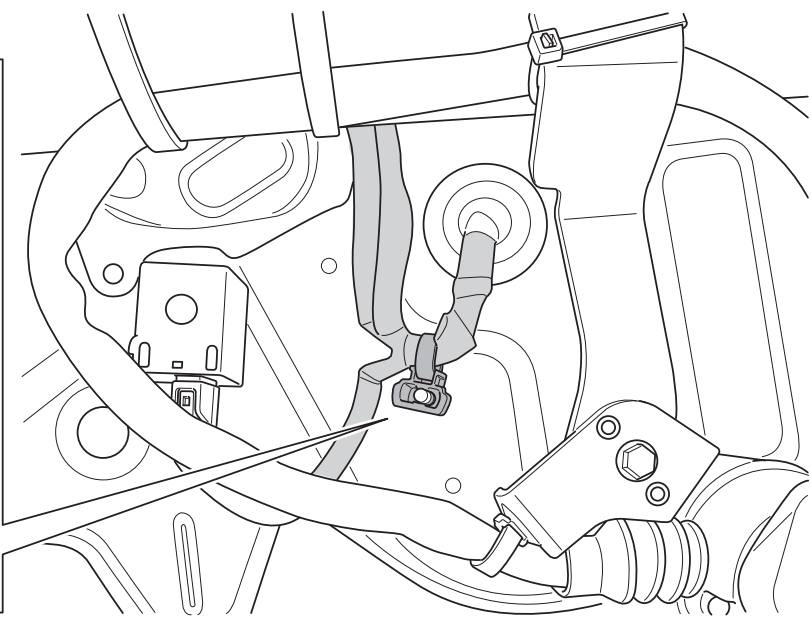
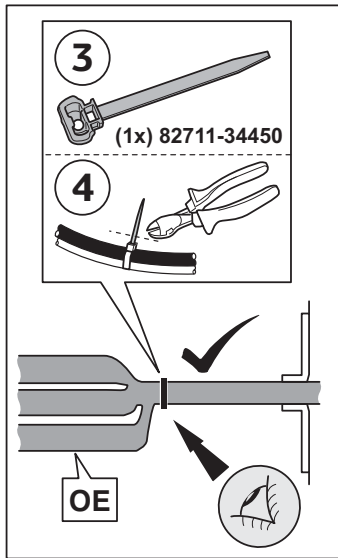
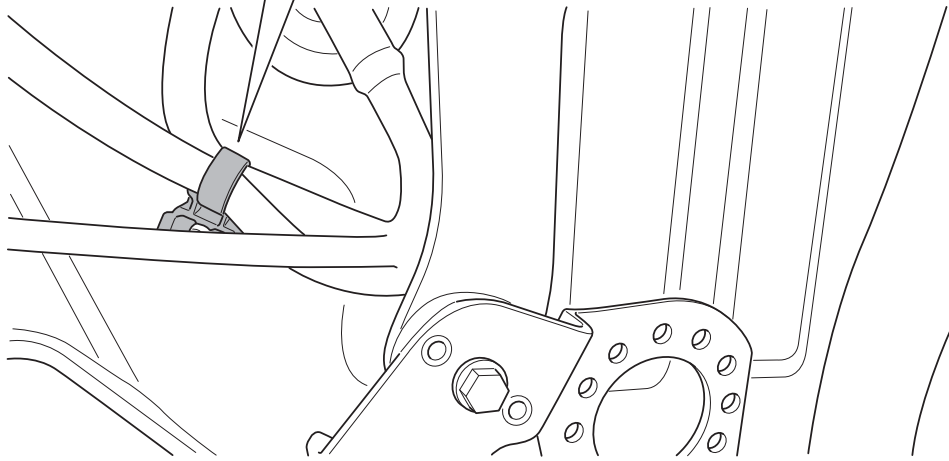
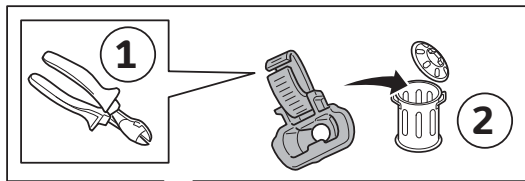
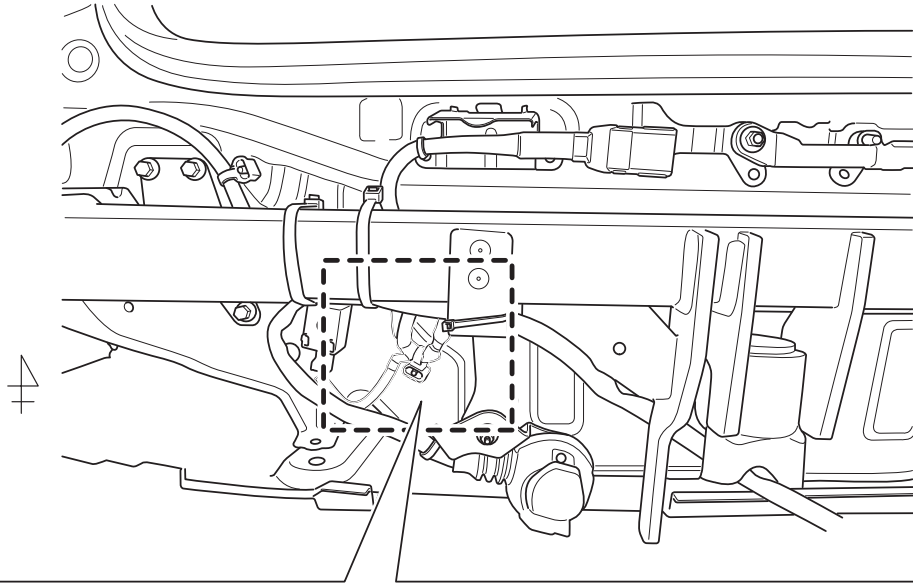

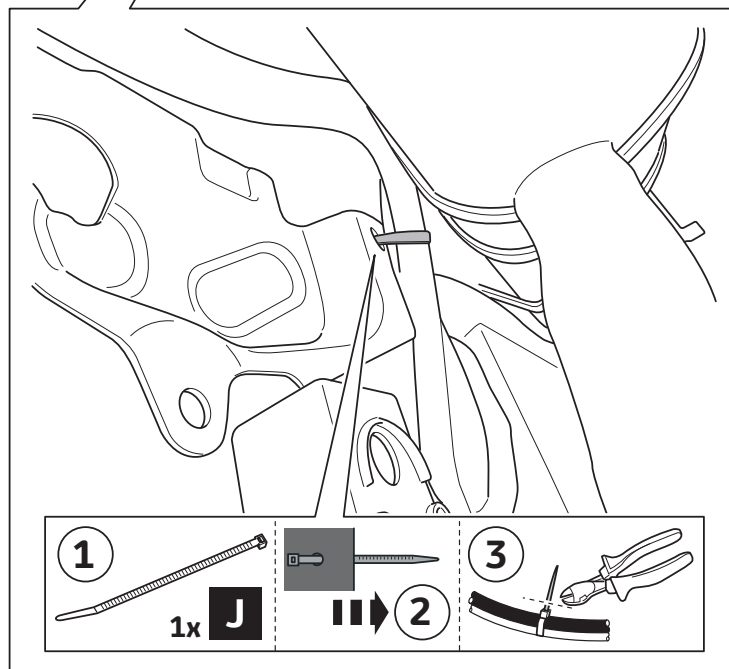
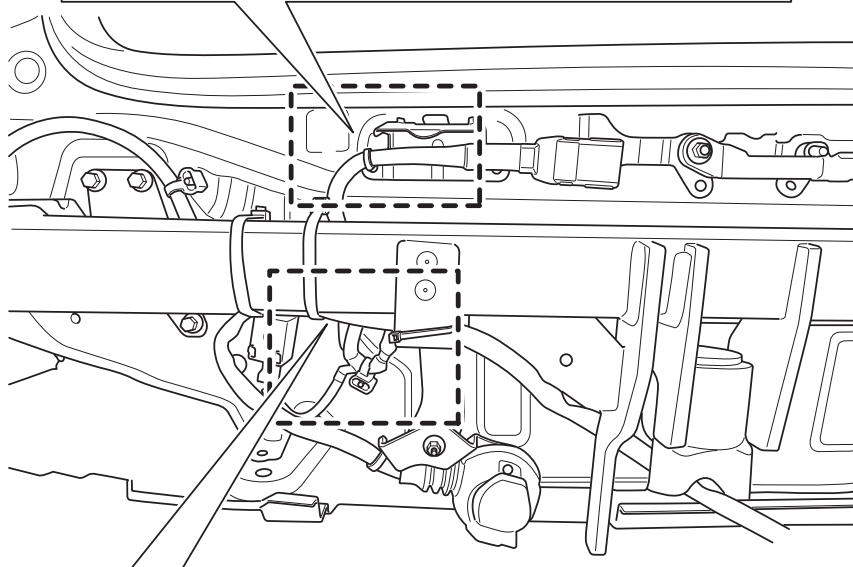
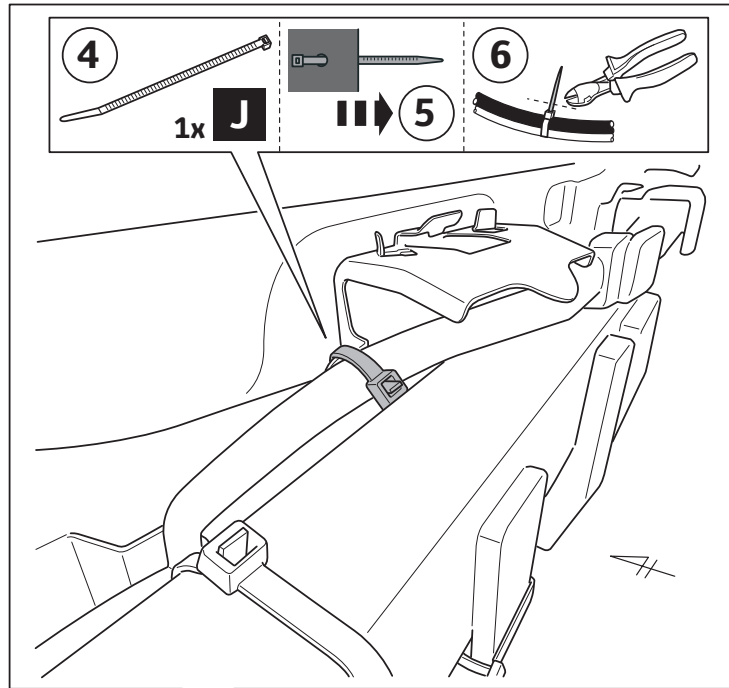
15

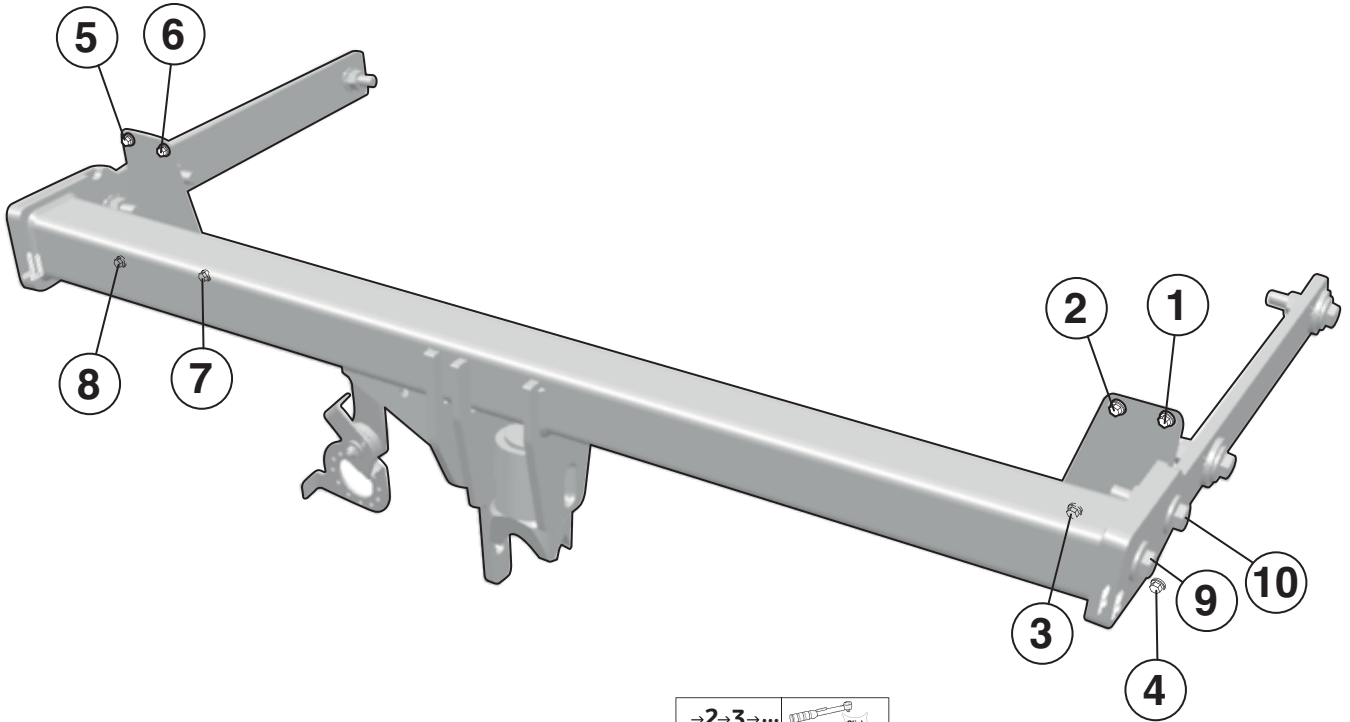







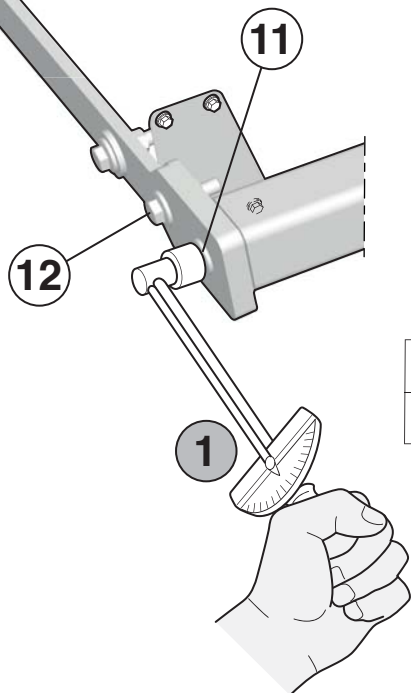
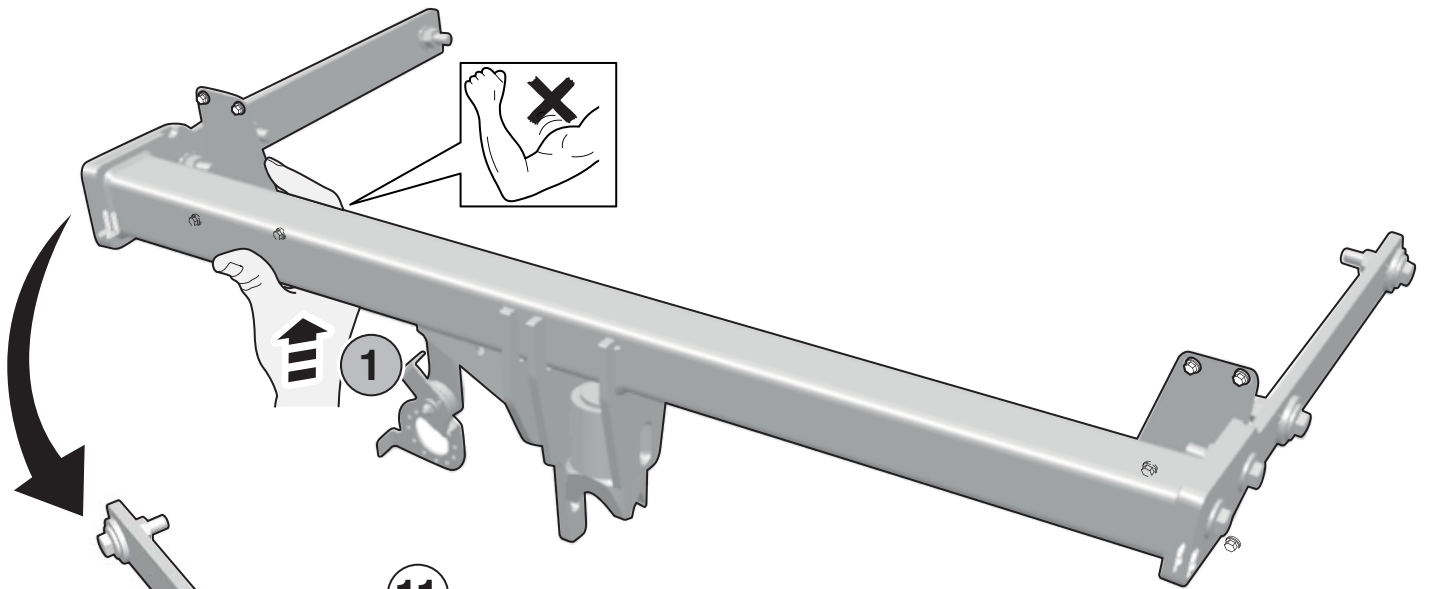







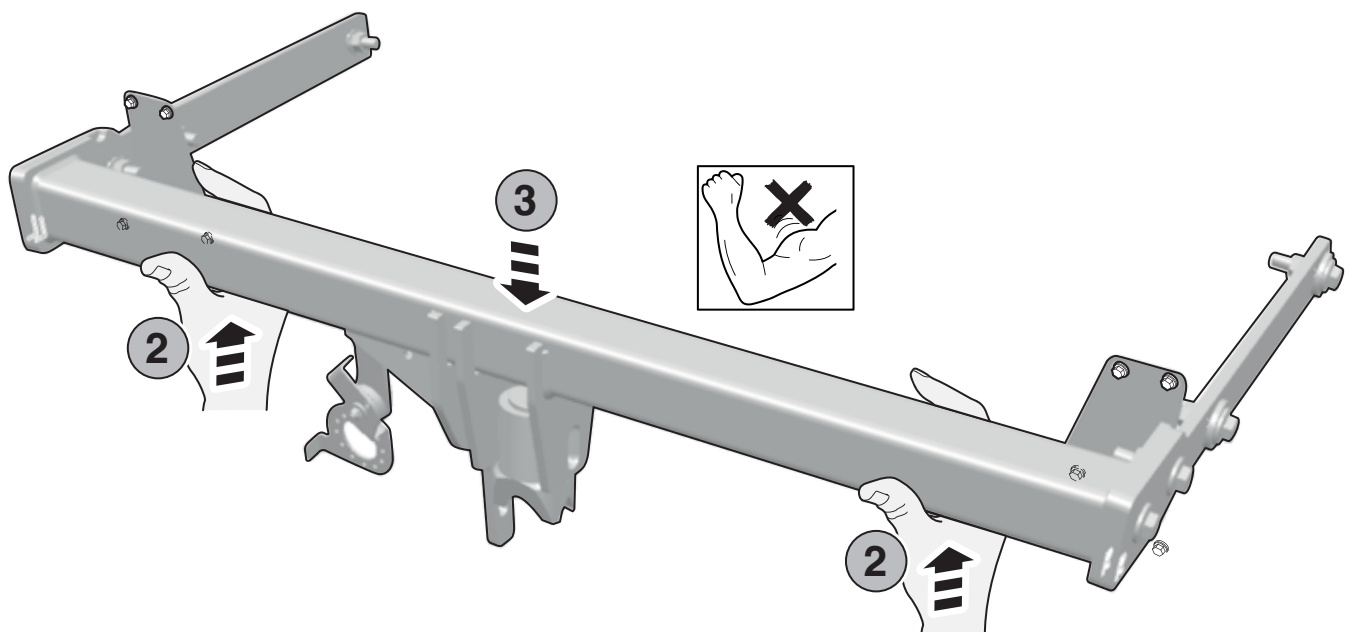

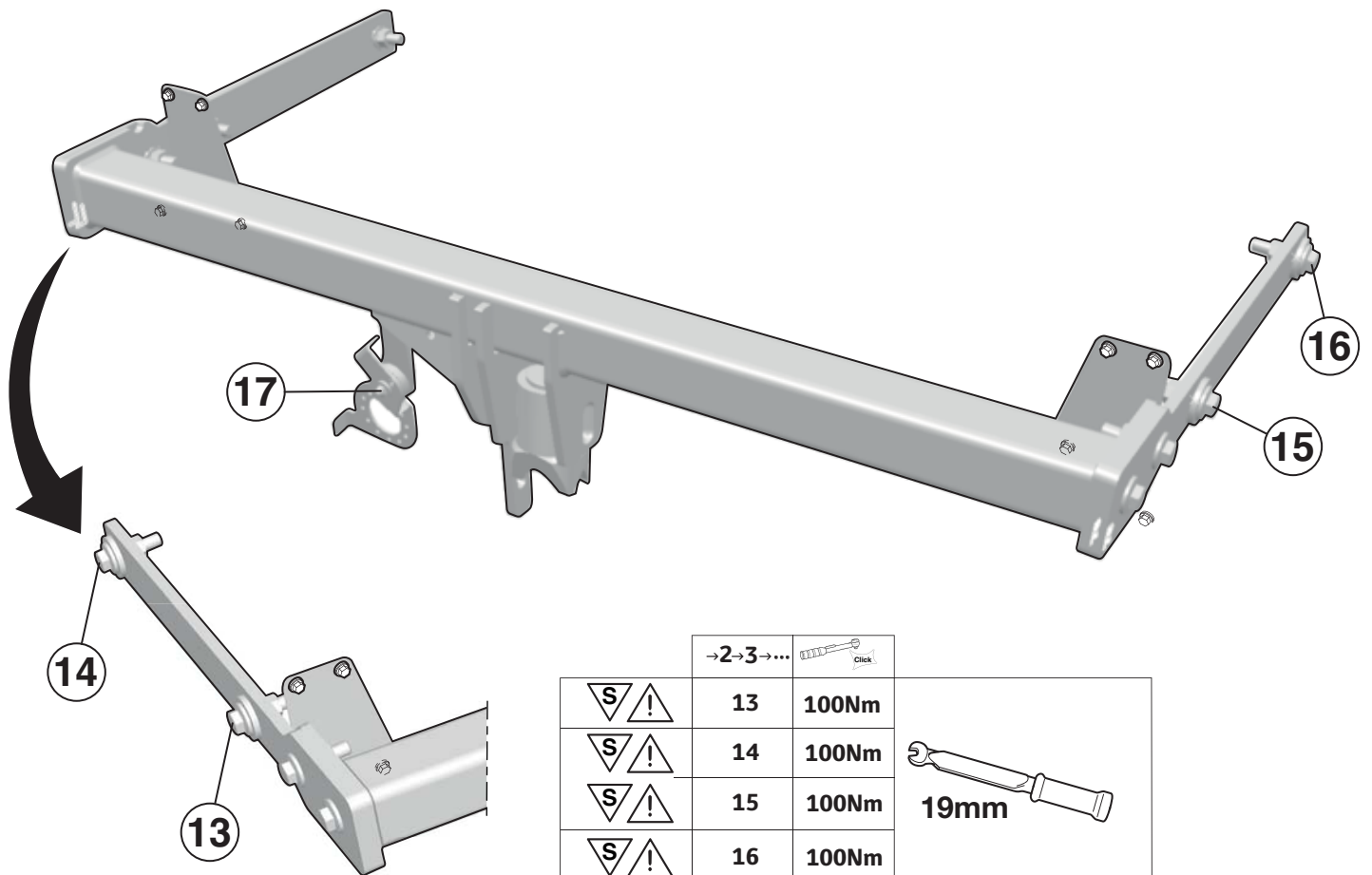
	->2->3->...		
	1	18Nm	 12mm
	2	18Nm	
	3	18Nm	
	4	18Nm	
	5	18Nm	
	6	18Nm	
	7	18Nm	
	8	18Nm	
	9	100Nm	 19mm
	10	100Nm	



		→2→3→...	 Click	
	11	100Nm		1
	12	100Nm	19mm	





	→2→3→...	 Click	
	13	100Nm	
	14	100Nm	 19mm
	15	100Nm	
	16	100Nm	
	17	3Nm	 10mm

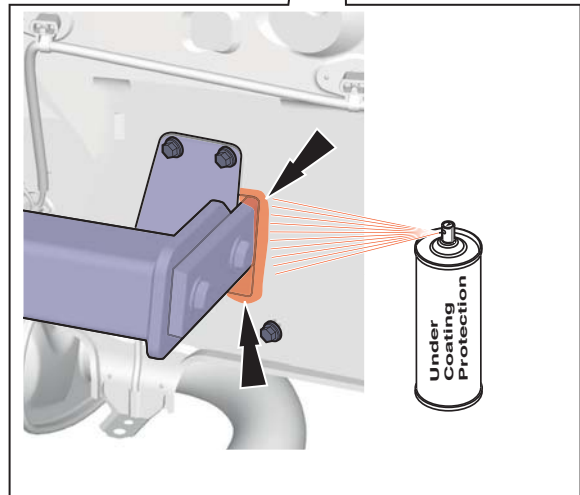
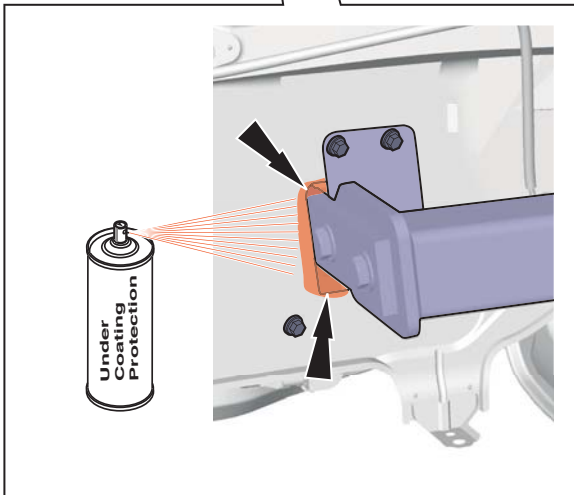
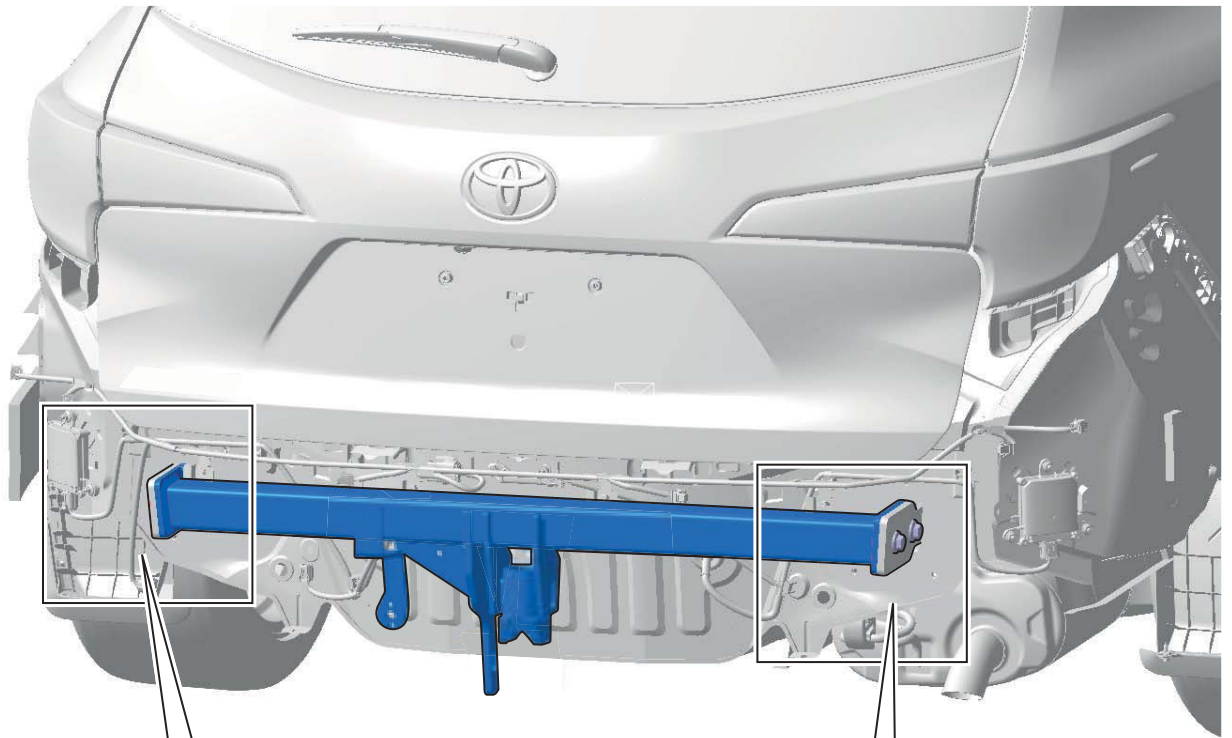

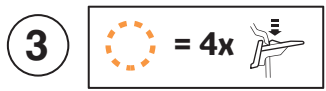
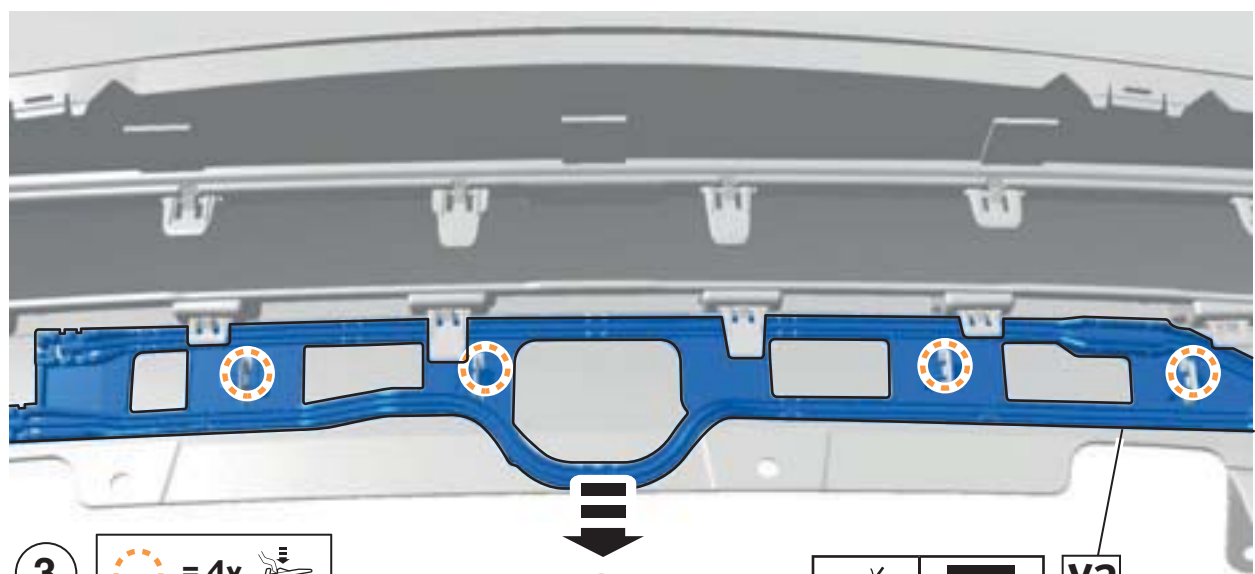
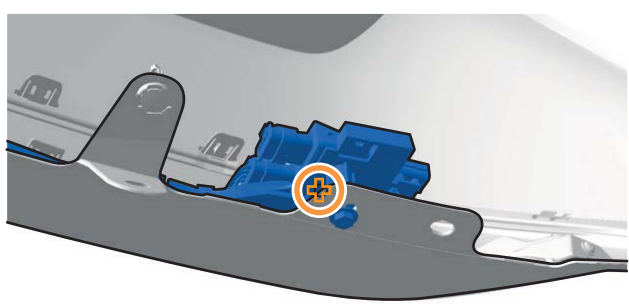
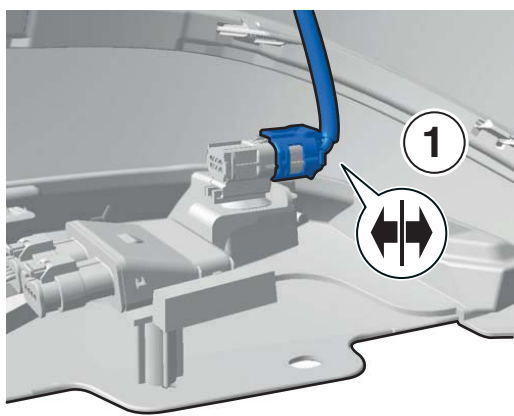
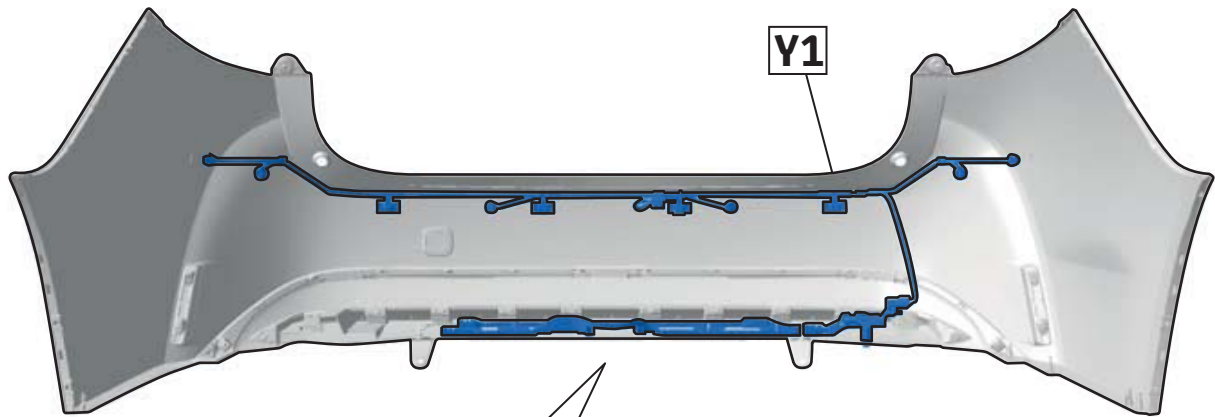
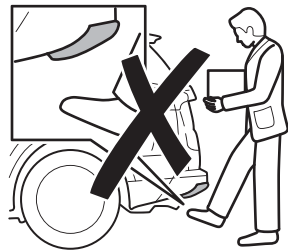
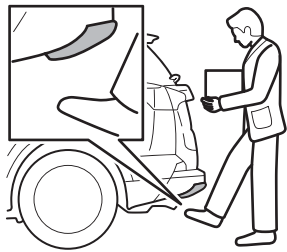

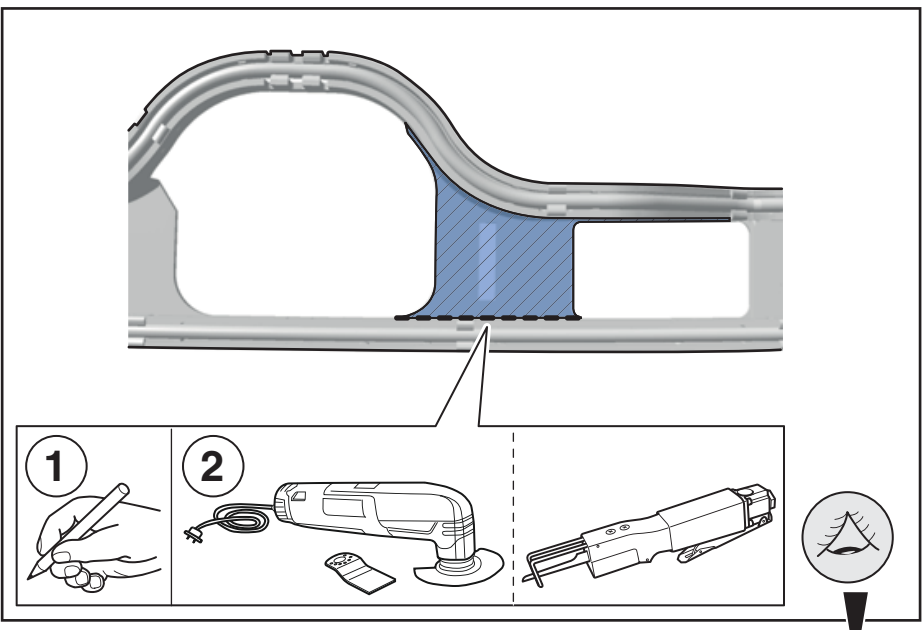
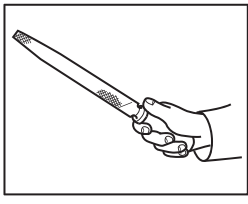
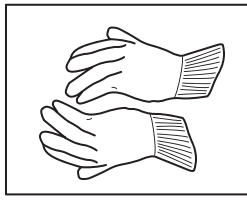
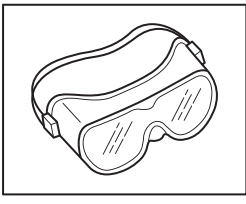
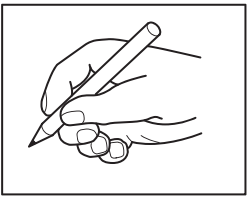

22

Y2

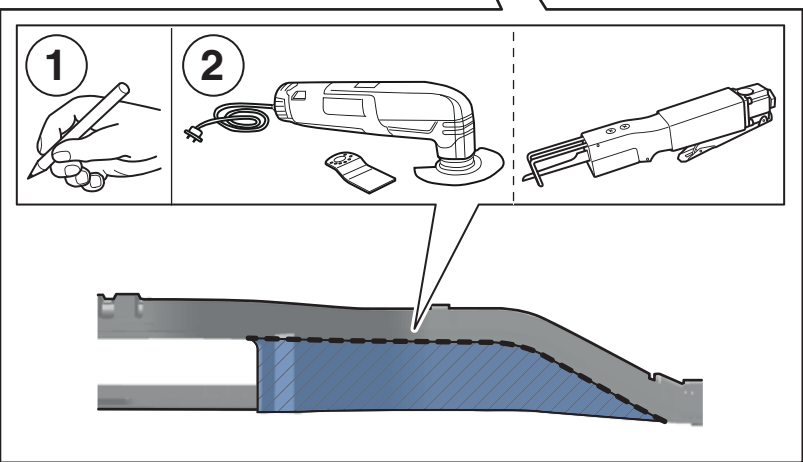

except TREK

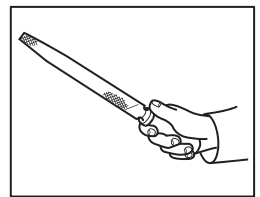
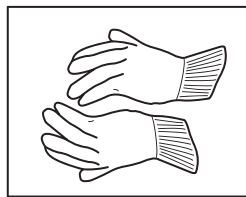
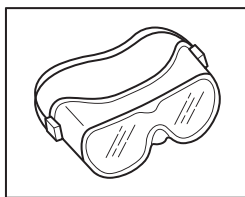
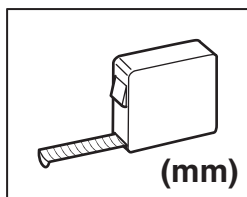
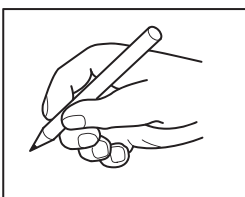
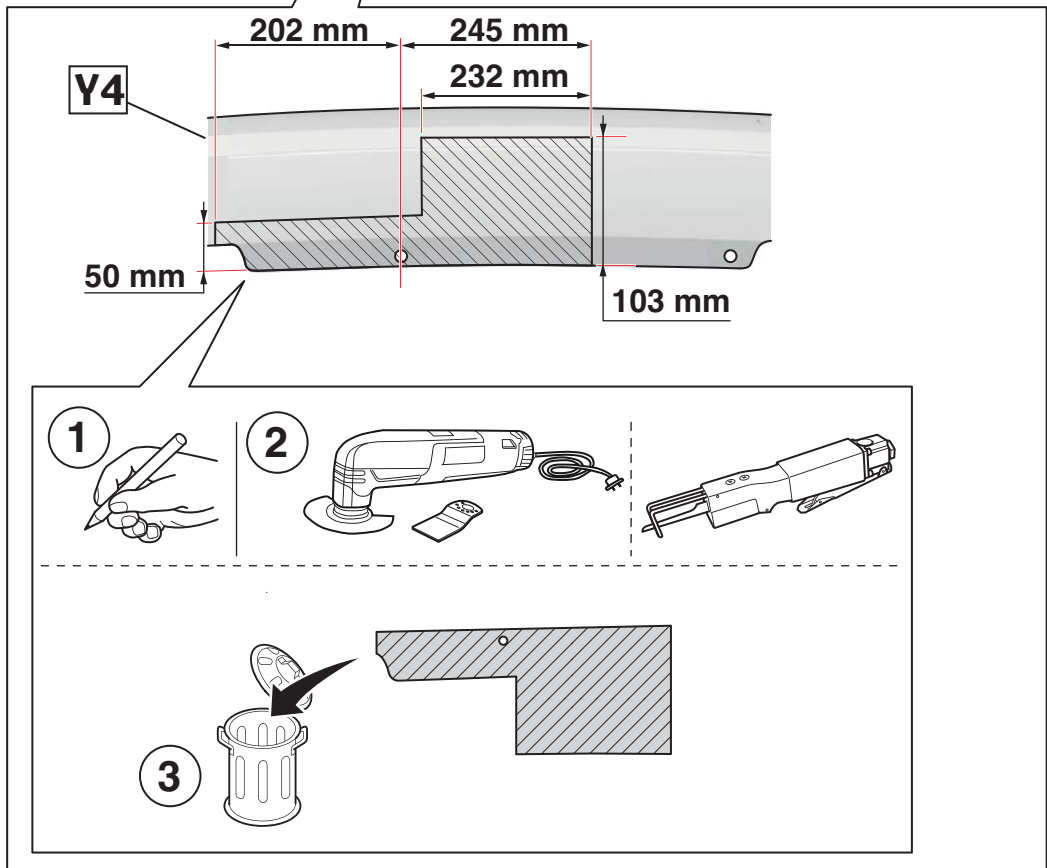
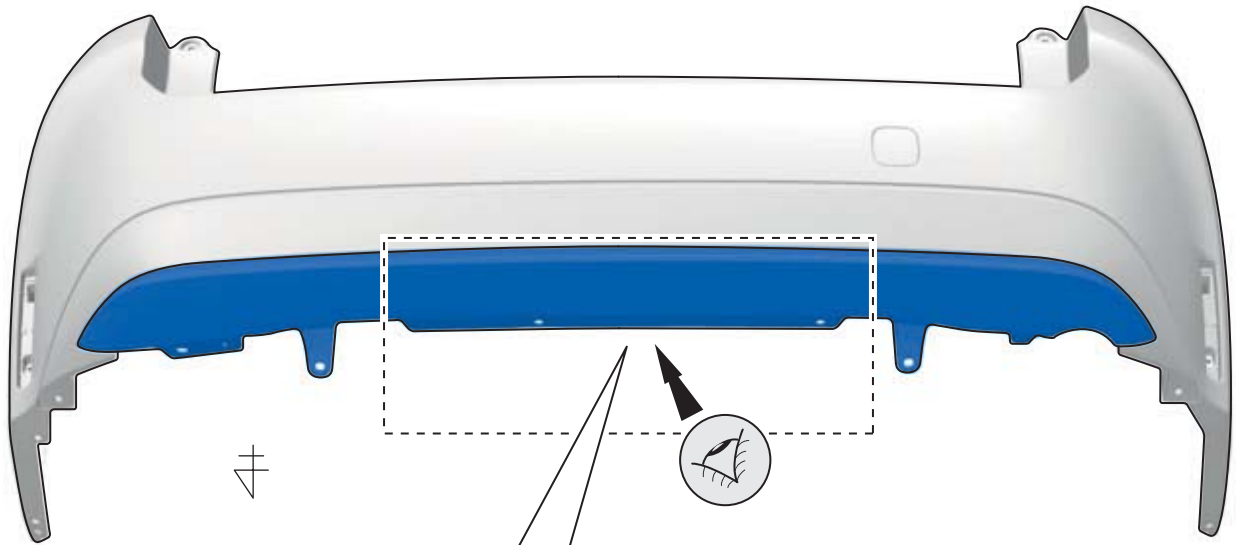

TREK

Y1

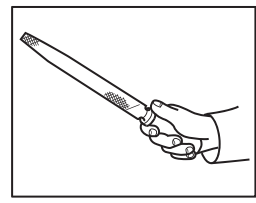
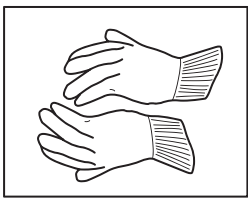
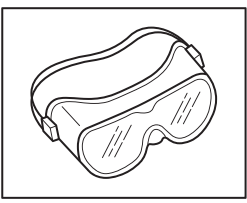
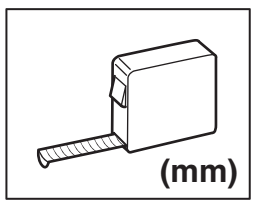
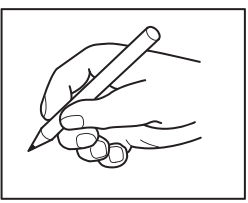
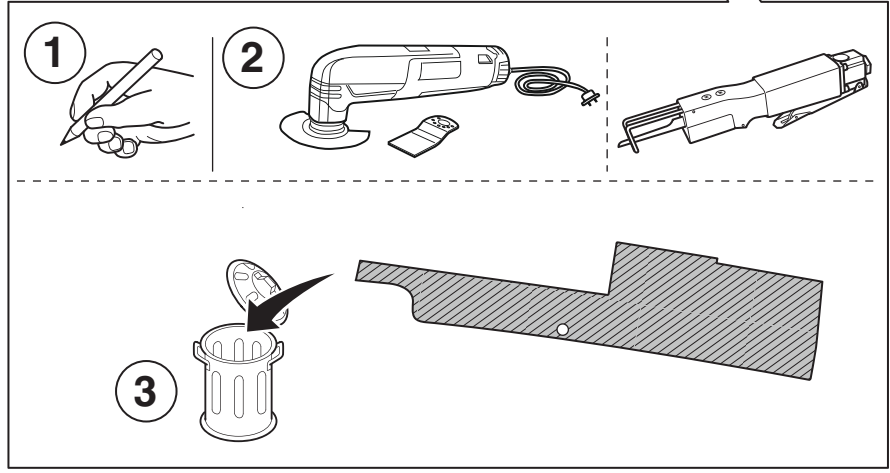
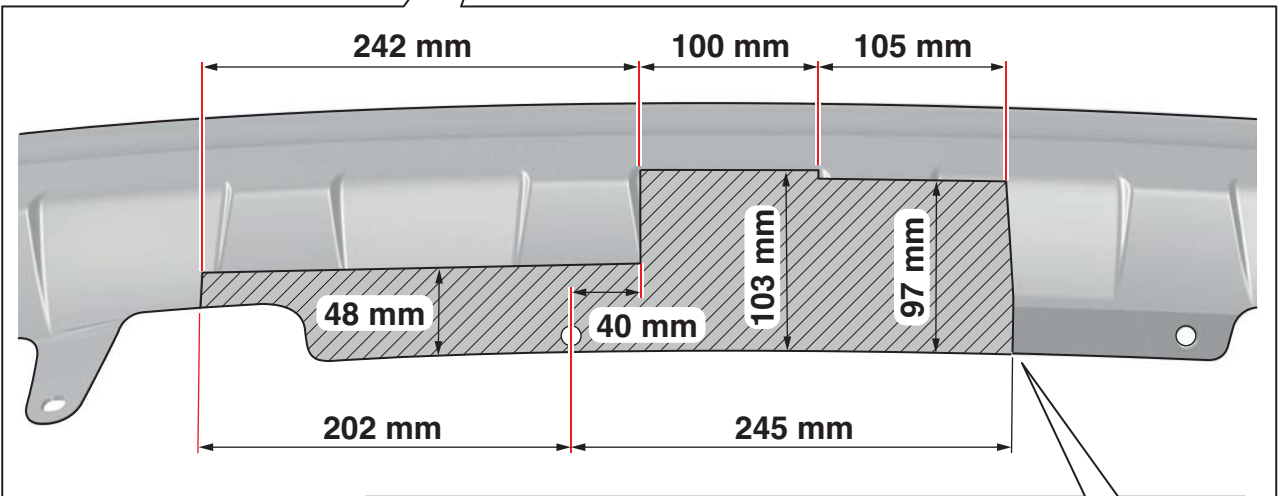
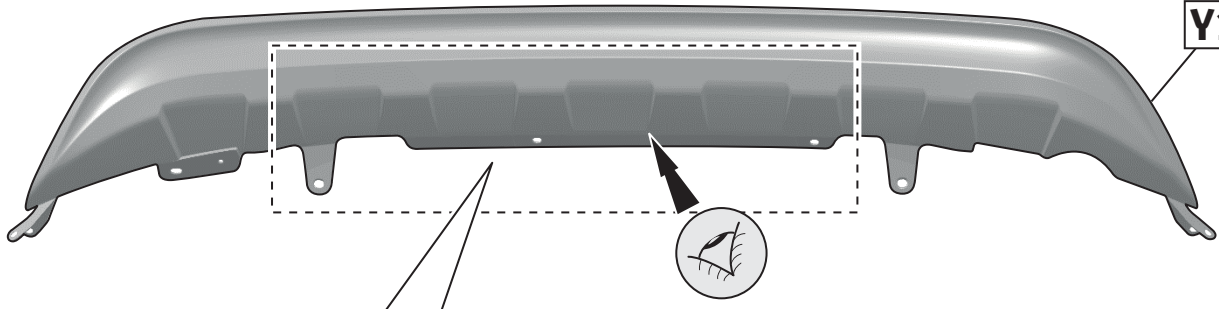

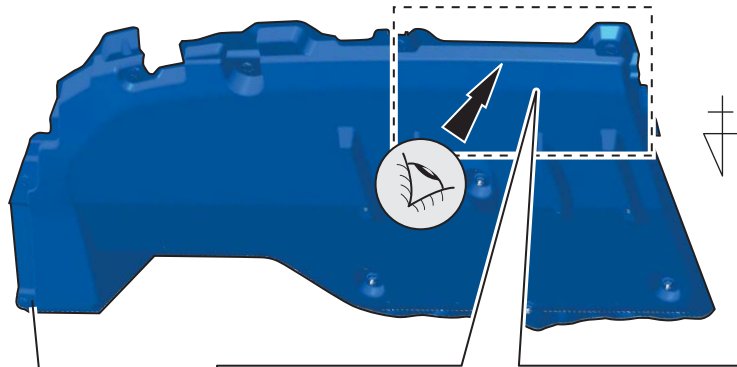

Y3

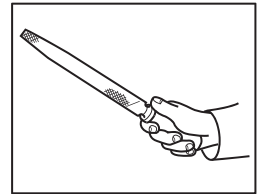
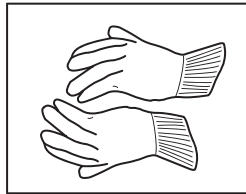
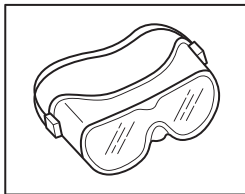
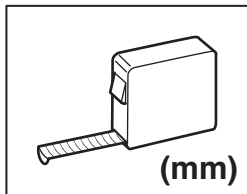
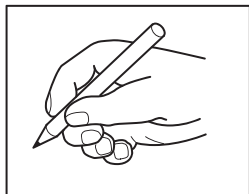
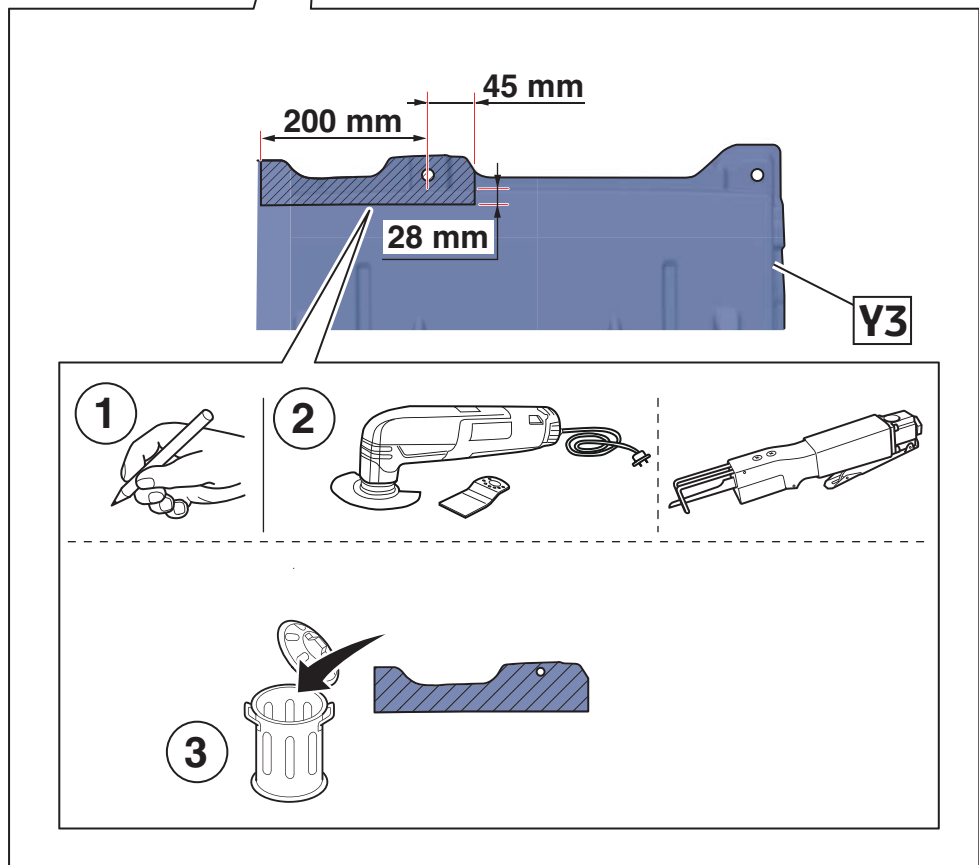

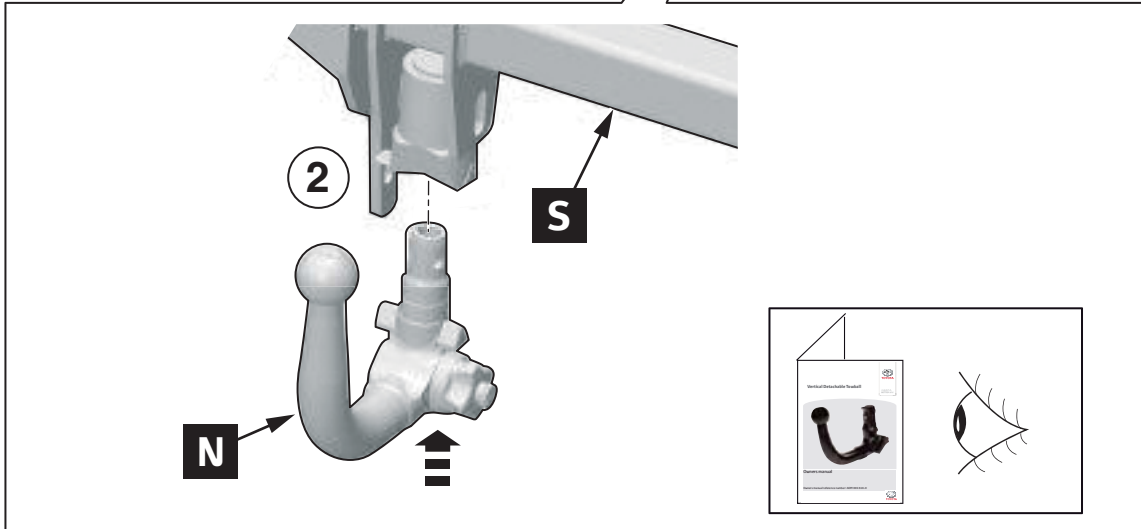
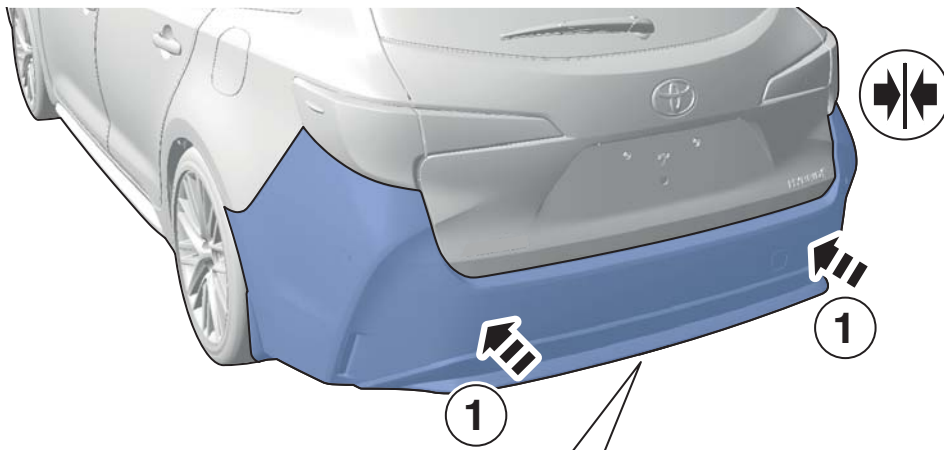

27

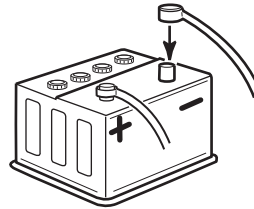
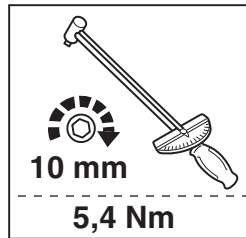

28

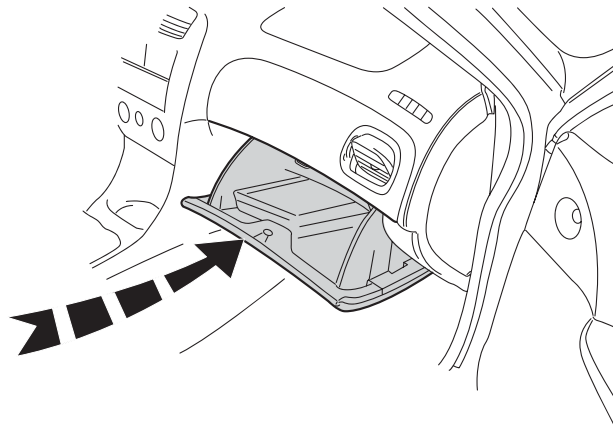

29

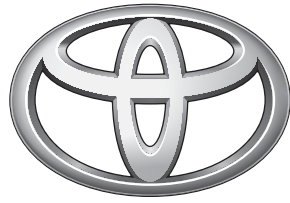

TOYOTA

OWNERS MANUAL

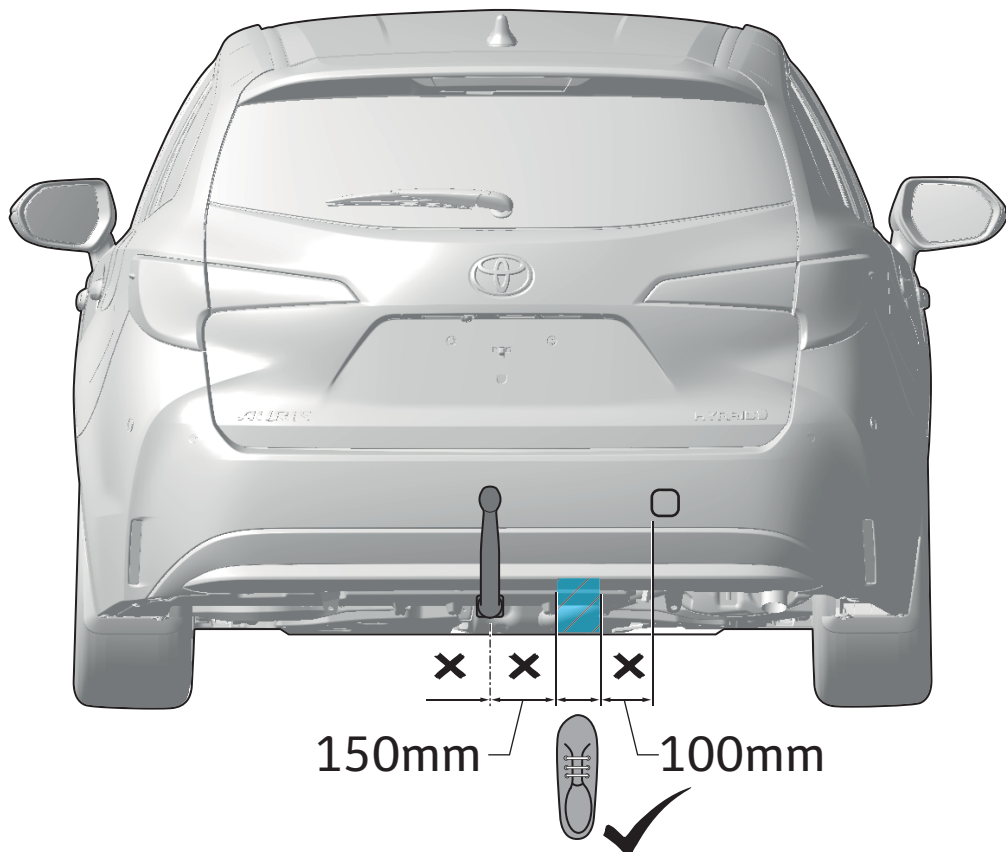
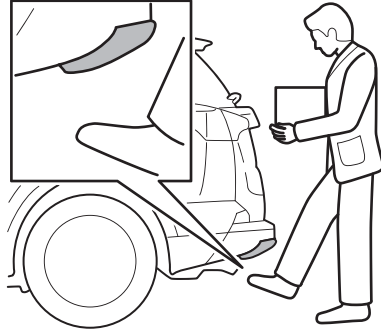

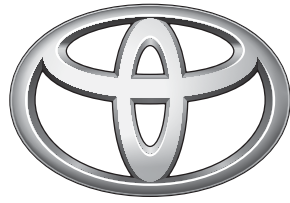

TOYOTA

Dispositivo di traino tipo: PZW960-02007
Per autoveicoli: Corolla (TS) 2019/02
Tipo funzionale: **E*1 **_DW***W

Classe e tipo di attacco: A50X
Omologazione: 55R-011848
Valore D: 8.6 kN
Carico Verticale max. S: 75 kg
Larghezza rimorchiabile per Caravan e T.A.T.S.: 2,45m vedere CARTA di CIRCOLAZIONE VEICOLO (motrice) + 70 cm = ..arrotondare ai 5 cm
Massa rimorchiabile: superiore (vedi D.M.28/05/85)
vedi carta di circolazione dell' autoveicolo

Per verificare l'idoneità del dispositivo di traino omologato a norma CEE 94/20, all'installazione sulla vettura su cui si intende procedere al montaggio, compilare la seguente formula (se necessario declassare la massa rimorchiabile):

$$D = \frac{T \times C}{T + C} \times 0,00 \geq 15,8 \text{ kN} \quad \text{..kN}$$

dove: T= Massa Complessiva Max. della motrice (in kg)
C= Massa Rimorchiabile Max. della motrice (in kg)

DA COMPILARE PER IL COLLAUDO

DICHIARAZIONE DI CORRETTO MONTAGGIO: la sottoscritta Ditta dichiara di aver montato in maniera corretta ed in conformità alle prescrizioni sia del costruttore del veicolo che del costruttore del dispositivo stesso il seguente dispositivo di attacco meccanico:

tipo:.....
Il dispositivo di attacco sopra indicato è stato installato su autoveicolo
modello:.....
targa:.....
Data:.....

TIMBRO e FIRMA

Si dichiara inoltre di aver informato l'utente del veicolo sull'USO e MANUTENZIONE del dispositivo stesso.

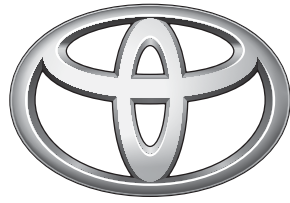

TOYOTA

CHECK SHEET











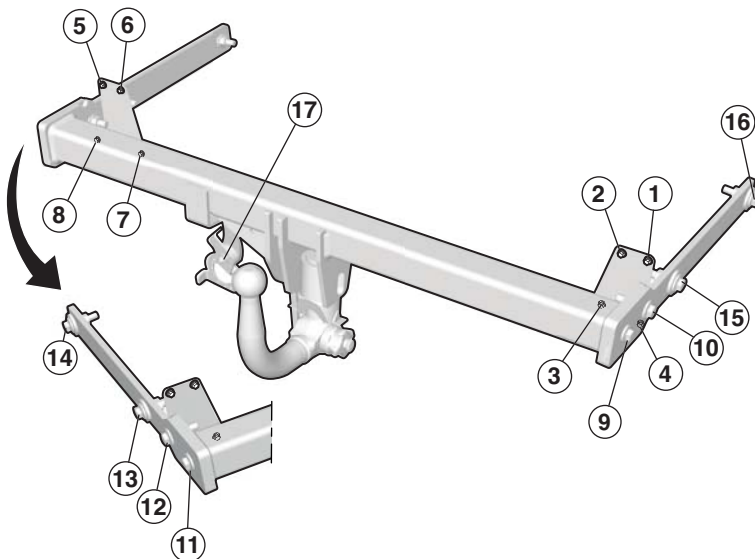
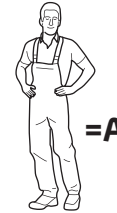
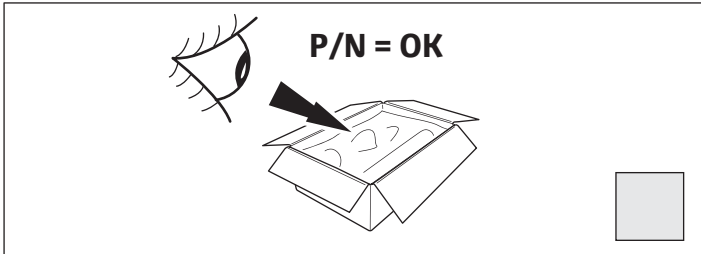

TOYOTA

Model/Year Corolla (TS) 2019/02 Towing hitch vertical detachable

ALWAYS A BETTER WAY

VIN n°



→2→3→...		A	B	Serial Number
1	18Nm	<input type="text"/>	<input type="text"/>	<input type="text"/>
2	18Nm	<input type="text"/>	<input type="text"/>	<input type="text"/>
3	18Nm	<input type="text"/>	<input type="text"/>	<input type="text"/>
4	18Nm	<input type="text"/>	<input type="text"/>	<input type="text"/>
5	18Nm	<input type="text"/>	<input type="text"/>	<input type="text"/>
6	18Nm	<input type="text"/>	<input type="text"/>	<input type="text"/>
7	18Nm	<input type="text"/>	<input type="text"/>	<input type="text"/>
8	18Nm	<input type="text"/>	<input type="text"/>	<input type="text"/>
	9	100Nm	<input type="text"/>	<input type="text"/>
	10	100Nm	<input type="text"/>	<input type="text"/>
	11	100Nm	<input type="text"/>	<input type="text"/>
	12	100Nm	<input type="text"/>	<input type="text"/>
	13	100Nm	<input type="text"/>	<input type="text"/>
	14	100Nm	<input type="text"/>	<input type="text"/>
	15	100Nm	<input type="text"/>	<input type="text"/>
	16	100Nm	<input type="text"/>	<input type="text"/>
	17	3Nm	<input type="text"/>	<input type="text"/>



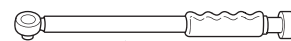
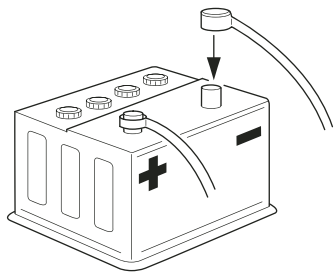

Click

Serial Number

5,4 Nm

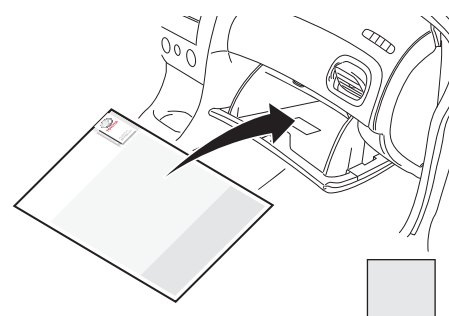
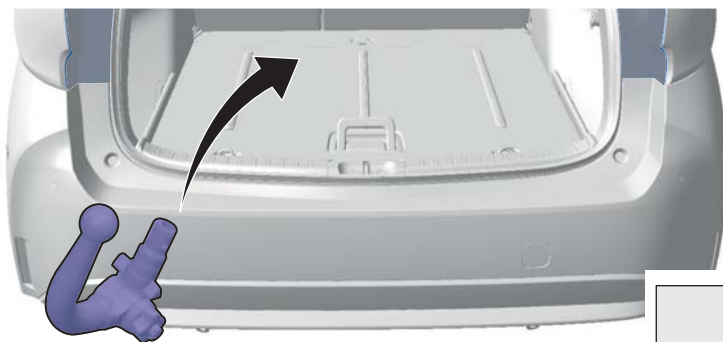
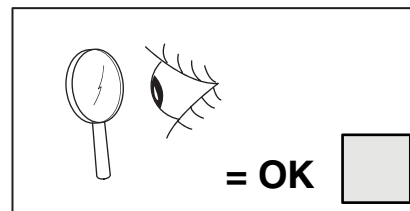
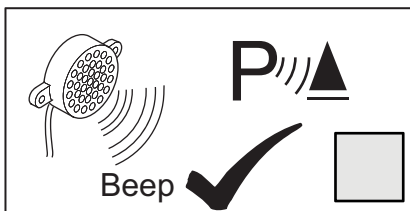
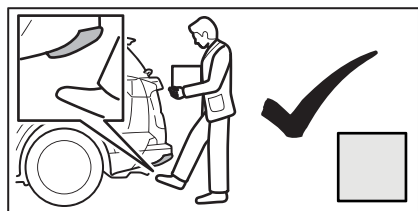
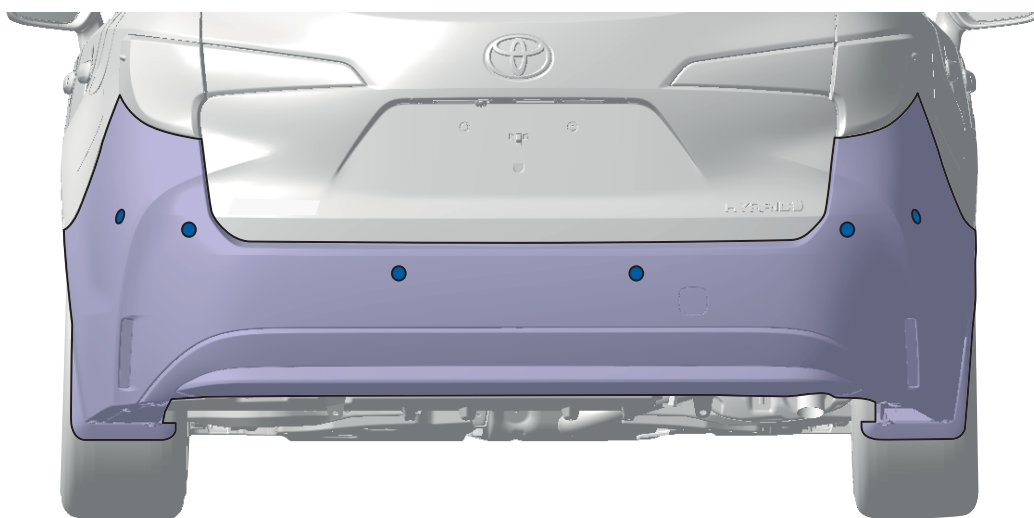

Installation Date:

. . / . . /

Technician Name & Signature:

Stamp: